

RADIO-CRAFT

HUGO GERNSBACK, Editor

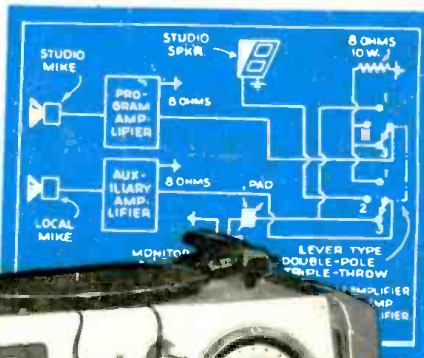

SPECIAL SOUND NUMBER

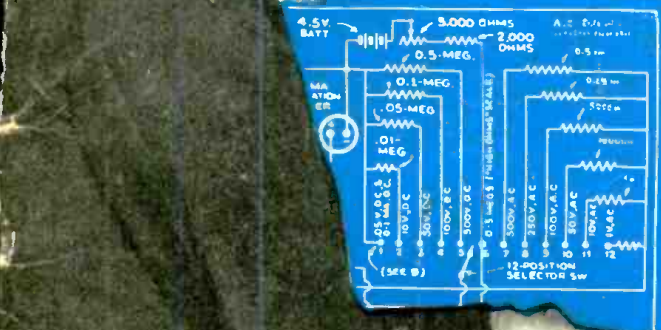
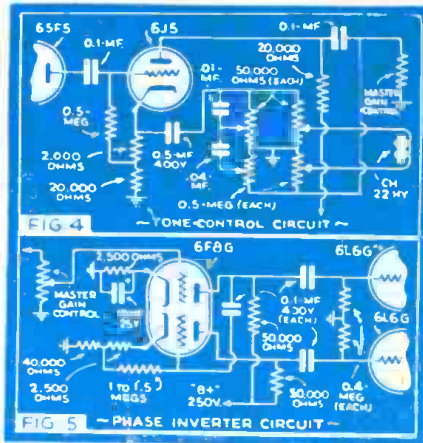

RADIO DETECTIVE



SKI BROADCAST



WIRELESS "P. A."

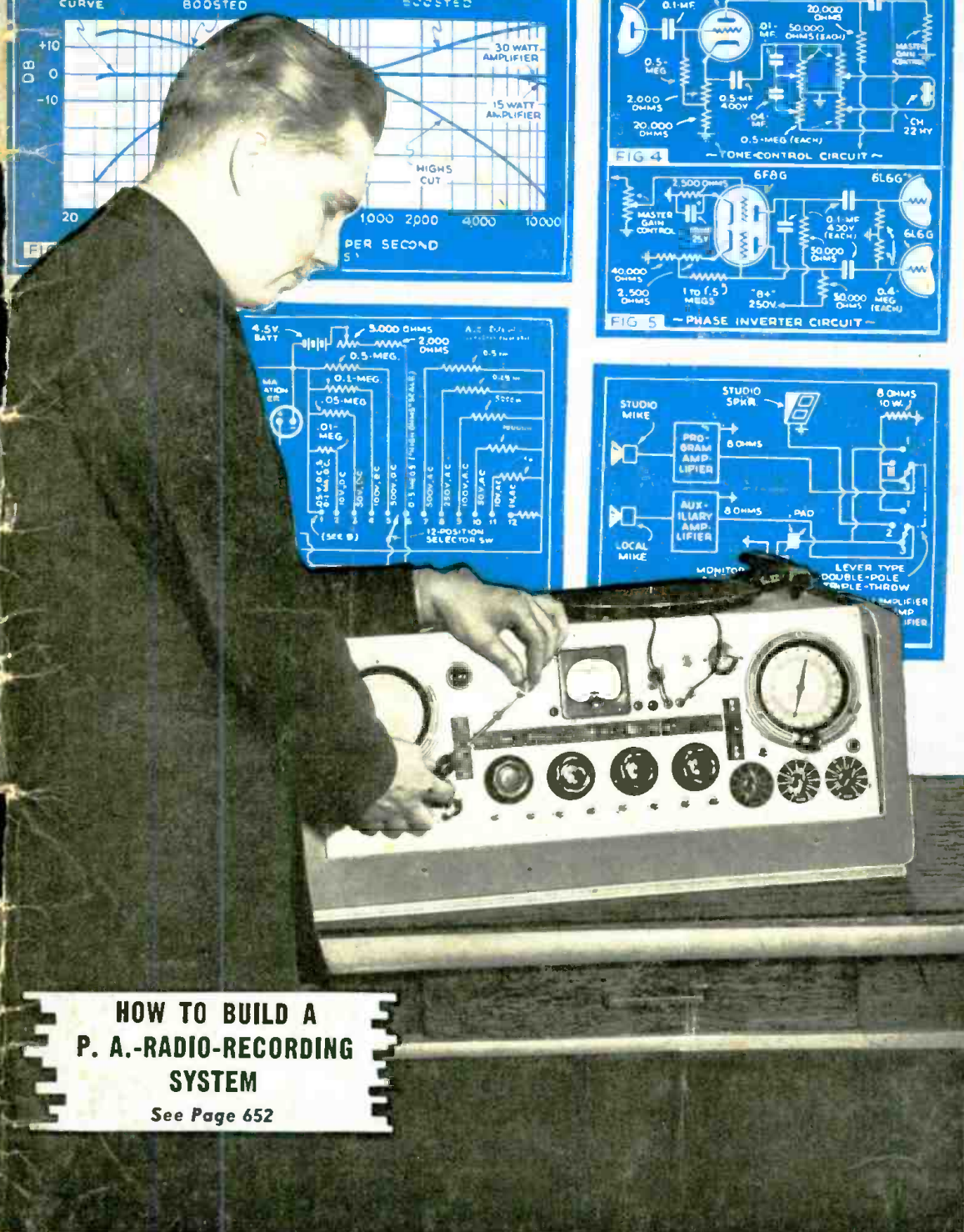

**HOW TO BUILD A
P. A.-RADIO-RECORDING
SYSTEM**
See Page 652

"Finest Dynamic I ever used"
 SAYS EVAN R. RUSHING, SOUND ENGINEER, HOTEL NEW YORKER

AMPERITE
P. G. DYNAMIC
 BRINGS STUDIO QUALITY
 TO ORDINARY P. A. JOBS

- **UNI-DIRECTIONAL.** NEW SUPERIOR ELIPSOID PICKUP PATTERN
- **ELIMINATES FEEDBACK** TROUBLE BECAUSE IT HAS LOWEST FEEDBACK POINT OF ALL DIAPHRAGM TYPE MICROPHONES
- **FLAT RESPONSE.** FREE FROM ANNOYING PEAKS, GIVING STUDIO-QUALITY REPRODUCTION.



The P.G. diaphragm follows air particle velocity where amplitude is a GRADIENT of the PRESSURE. In ordinary dynamics amplitude is restricted from following air particle velocity.

The P.G. DYNAMIC is a radical improvement in this type of microphone. You can actually hear the difference. Case is designed according to modern acoustic principles. Rugged, not affected by temperature, altitude or humidity. HAS UNUSUALLY HIGH OUTPUT. —55 DB.

MODEL PGH (PGL 200 ohms). Excellent for high fidelity P.A. installations, broadcast studio, and professional recording. With switch, cable connector, 25' cable. Chrome finish. LIST \$32.00 (40, 10,000 C.P.S.)

MODEL PGAH (PGAL 200 ohms). For speech and music. 70-8000 C.P.S. Switch, cable connector, 12' cable. Chrome. LIST \$25.00

**COMBINATION VELOCITY-DYNAMIC
 ACHIEVED WITH
 ACOUSTIC COMPENSATOR**



An exclusive Amperite feature: By moving up the Acoustic Compensator you change the AMPERITE VELOCITY to a DYNAMIC microphone without peaks. At the same time you reduce the back pick-up, making the microphone practically UNI-DIRECTIONAL.

WITH ACOUSTIC COMPENSATOR:
 MODEL RBHk; RBMk (200 ohms) with switch, cable connector.

Chrome, LIST \$42.00

RSHk; RBSk (200 ohms). Switch, cable connector, Acoustic Compensator.

Chrome or Gunmetal. LIST \$32.00

AMPERITE KONTAK MIKE
 Puts Musical Instruments Across



So beautiful is the tone produced with the Kontak Mike, that it was used in the Philadelphia Symphony to amplify a mandolin solo. Gives excellent results with any amplifier, radio sets, and record players.

MODEL SKH (hi-imp) LIST \$12.00

MODEL KKH, with hand volume control.. LIST 18.00

Plug extra List 1.50

FOOT PEDAL, for making beautiful crescendos LIST 12.00

WRITE FOR FREE SALES AIDS **AMPERITE** ©. 561 BROADWAY, N. Y. U. S. A.

Specify **AMPERITE**



A FREE LESSON SHOWED BILL HOW HE COULD MAKE GOOD PAY IN RADIO



BILL, YOU'RE ALWAYS FOOLING WITH RADIO -- OUR SET WON'T WORK -- WILL YOU FIX IT?

I'LL TRY, MARY, I'LL TAKE IT HOME TONIGHT



I CAN'T FIND OUT WHAT'S WRONG -- GUESS I'LL MAKE A FOOL OF MYSELF WITH MARY



HELLO, BILL -- GOT A TOUGH ONE TO FIX? LET ME HELP YOU



HELLO JOE -- WHERE'VE YOU BEEN LATELY -- AND WHERE DID YOU LEARN ANYTHING ABOUT RADIO?

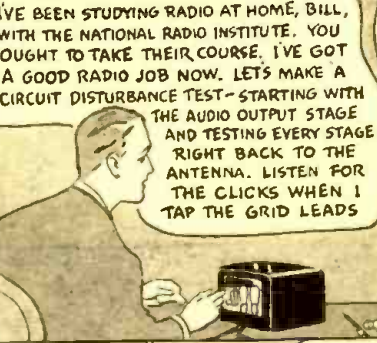

I'VE BEEN STUDYING RADIO AT HOME, BILL, WITH THE NATIONAL RADIO INSTITUTE. YOU OUGHT TO TAKE THEIR COURSE. I'VE GOT A GOOD RADIO JOB NOW. LET'S MAKE A CIRCUIT DISTURBANCE TEST -- STARTING WITH THE AUDIO OUTPUT STAGE AND TESTING EVERY STAGE RIGHT BACK TO THE ANTENNA. LISTEN FOR THE CLICKS WHEN I TAP THE GRID LEADS



SAY -- WHERE DID YOU LEARN THAT TEST? IT'S A GOOD ONE

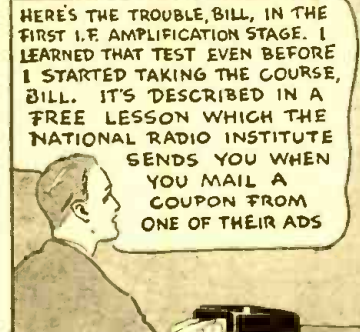

HERE'S THE TROUBLE, BILL, IN THE FIRST I.F. AMPLIFICATION STAGE. I LEARNED THAT TEST EVEN BEFORE I STARTED TAKING THE COURSE, BILL. IT'S DESCRIBED IN A FREE LESSON WHICH THE NATIONAL RADIO INSTITUTE SENDS YOU WHEN YOU MAIL A COUPON FROM ONE OF THEIR ADS



I'VE SEEN THEIR ADS BUT I NEVER THOUGHT I COULD LEARN RADIO AT HOME -- I'LL MAIL THEIR COUPON RIGHT AWAY



I'M CONVINCED NOW THAT THIS COURSE IS PRACTICAL AND COMPLETE. I'LL ENROLL NOW

AND THEN I CAN MAKE REAL MONEY FIXING RADIO SETS

OR INSTALL AND SERVICE LOUD SPEAKER SYSTEMS



OR GET A JOB WITH A RADIO BROADCASTING OR TRANSMITTING STATION

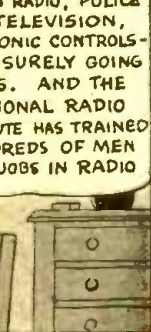

AVIATION RADIO, POLICE RADIO, TELEVISION, ELECTRONIC CONTROLS -- RADIO IS SURELY GOING PLACES. AND THE NATIONAL RADIO INSTITUTE HAS TRAINED HUNDREDS OF MEN FOR JOBS IN RADIO

I will send you a Lesson on Radio Servicing Tips FREE TO SHOW HOW PRACTICAL IT IS TO TRAIN AT HOME FOR GOOD JOBS IN RADIO



J. E. SMITH, President, National Radio Institute Established 25 years

He has directed the training of more men for the Radio Industry than any one else.



YOU CERTAINLY KNOW RADIO SOUNDS AS GOOD AS THE DAY I BOUGHT IT.

THANKS! IT CERTAINLY IS EASY TO LEARN RADIO THE N.R.I. WAY. I STARTED ONLY A FEW MONTHS AGO, AND I'M ALREADY MAKING GOOD MONEY.

THIS SPARE TIME WORK IS GREAT -- FUN AND PRETTY SOON I'LL BE READY FOR A FULL TIME JOB

Even if you have only a slight interest in Radio, get this sample Lesson. It is a catalog of common Radio receiver troubles, their causes and remedies. Mail the coupon. Learn how practical N. R. I.'s 50-50 method makes learning Radio at home. Discover the many opportunities the N. R. I. Course opens for well-paying full time jobs.

Why Many Radio Technicians Make \$30, \$40, \$50 a Week

Millions of dollars in defense orders on top of a record year for Radio are opening new opportunities for trained men. Radio Technicians are well paid because they use their minds as well as their hands. It takes both to repair a home or auto Radio set; to operate and maintain a Broadcast or Commercial transmitting station; to install, operate and repair Police, Aviation, Experimental Radio and Television equipment. That's why so many fellows who become Radio Technicians are able to jump their pay; why others operate their own full time Radio Service Businesses. Many fix Radios in spare time

while holding other jobs because of the extra money in the work.
Beginners Quickly Learn to Earn \$5 to \$10 a Week in Spare Time
Find out how N. R. I. trains you to make extra money quickly. Many N. R. I. students report making extra money in spare time within a few months. Many pay for their entire Course with extra money made in spare time while learning.



You Get This Professional Servicing Instrument

This instrument makes practically any test you will be called upon to make in your Radio work on both spare time and full time jobs. It can be used on the test bench, or carried along when out on calls. It measures A.C. and D.C. voltages and currents; tests resistances; has a multi-band oscillator for tuning any set, old or new. You get this instrument as part of your N. R. I. Course.

Mail the Coupon
Get our SAMPLE LESSON and a copy of "Rich Rewards in Radio" FREE. You'll see letters from men who got into Radio this way, telling what Radio means to them; what they are doing and earning. You'll see why the N. R. I. Course is easy to study, fascinating to learn, practical to use. You'll get facts on Television and other fast-growing branches of Radio. ACT NOW. Write your name and address on the coupon below. Paste it on a penny postcard or mail it in an envelope -- RIGHT NOW.
J. E. SMITH, President
Dept. IEX, National Radio Institute
Washington, D. C.



J. E. SMITH, President, Dept. IEX National Radio Institute, Washington, D. C.

Dear Mr. Smith: Mail me FREE, without obligation, your Sample Lesson and 64-page book "Rich Rewards in Radio" which tells about Radio's spare-time and full-time opportunities and explains your 50-50 method of training men at home to be Radio Technicians. (No salesman will call. Write Plainly.)

OH BILL -- I'M SO GLAD I ASKED YOU TO FIX OUR RADIO. IT GOT YOU STARTED THINKING ABOUT RADIO AS A CAREER. AND NOW YOU'RE GOING AHEAD SO FAST

OUR WORRIES ARE OVER. I HAVE A GOOD JOB NOW, AND THERE'S A BIG FUTURE AHEAD FOR US IN RADIO

DRAFT REGISTRANTS!
Hundreds of men who know Radio when they enter military service are going to win specialist ratings in the Army, Navy and Marine Corps. These ratings pay up to 6 times a private's or seaman's base pay, in addition to carrying extra rank and prestige! If you ARE NOT called, you are getting into Radio when the Government is pouring millions into the Radio industry to buy Defense equipment on top of boom civilian Radio business. Whether you enlist or wait for conscription -- IT'S SMART TO LEARN RADIO -- NOW!

Age.....
Name.....
Address.....
City..... State.....
14X1

RADIO-CRAFT

HUGO GERNSBACK, *Editor-in-Chief*

N. H. LESSEM
Associate Editor

THOS. D. PENTZ
Art Director

R. D. WASHBURNE, *Managing Editor*

IN THE NEXT ISSUE!

- How to Build and Use a Leak Detector
- Selling Radio Service
- How to Build a Miniature Portable Transmitter
- Oriental Slant on Radio
- Theory and Design of Coils for F.M. Receivers
- Developments in Personal Portables

Contents MAY, 1941 Issue

VOLUME XII -- NUMBER 11

Mailbag	643
Editorial: Radiobotage	Hugo Gernsback 649
The Radio Month in Review	650

SOUND

How to Build a Modern 30/15-Watt P.A. - Radio - Recording Console, Part I (cover feature)	R. J. Bergemann, Jr. 652
Measuring Distortion in Audio-Frequency Amplifiers	656
Broadcasting	658
How to Make Dynamic Tests on Audio Amplifiers ..	Ted Ladd 660
Ultra-Mobile P.A. System	Edwin F. Longley 664
Index to "Radio-Craft" Articles on Sound	665
Adding an "Eye" to A.F. Amplifiers—and Other Practical Ideas	Harold Davis 666
Modern Circuit Features of a Semi-Professional 10-Watt Recording and Playback Amplifier	A. C. Shaney 668
Microphones—and How They Work	J. de Boer 673
Sound Engineering—No. 17	Conducted by A. C. Shaney 679

SERVICING

RADIO SERVICE DATA SHEETS:

No 306—RCA Victor Model VHR-307 Home Recording - Phono - Radio Combination (Chassis No. RC-555)	682
No. 307—Ditto	683
Operating Notes	684, 686
New Circuits in Modern Radio Receivers—No. 44	F. L. Sprayberry 685
Servicing Record Players	Willard Moody 688
F.M. Receiver I.F. Channel Design	M. Dezettel, W9SFW 691

DEPARTMENTS, ETC.

Mailbag	643
The Radio Month in Review	650
Sound Engineering—No. 17	Conducted by A. C. Shaney 679
RADIO SERVICE DATA SHEETS (See Servicing)	682, 683
Operating Notes	684, 686
New Circuits in Modern Radio Receivers—No. 44	F. L. Sprayberry 685
"Sayville Once More—an attack on The Electrical Experimenter"	687
Latest Radio Apparatus	692
Classified Radio Directory—Section II (Revised)	696
Shop Notes—Kinks—Circuits	703
Book Reviews	704



Published by Radcraft Publications, Inc. Publication office: 29 Worthington Street, Springfield, Mass. Editorial and Advertising Offices: 20 Vesey Street, New York City. Chicago Advertising Office: RADIO-CRAFT, 520 North Michigan Avenue, Chicago, Ill.

RADIO-CRAFT is published monthly, on the first of the month preceding that of date; subscription price is \$2.50 per year in U. S. (In foreign countries, 75c additional per year to cover postage; Canada, 50c additional.) Entered at the post office at Springfield as second-class matter under the act of March 3, 1879.



Foreign Agents:

London—Gorrings's American News Agency, 9A Green St., Leicester Square, W. C. 2, England.
 Paris—Messageries Dawson, 4 Rue Faubourg, Poissonniere, France.
 Melbourne—McGill's Agency, 179 Elizabeth St., Australia.
 Dunedin—James Johnston, Ltd., New Zealand.



Text and illustrations of this magazine are copyright and must not be reproduced without permission of the copyright owners.



Copyright 1941 Radcraft Publications, Inc.

**MORE ANENT HOMER BUCK'S
"ALIGNING SUPERHETS"**

(Continued from last month)

Dear Editor:

Continuing, "When alignment is attempted with an oscillator, there is no impedance matching, the signal strength is not like that of a broadcast station and the oscillator is certainly not like the radio's own antenna. . . ." Let's take the first statement. No impedance matching. The generator is connected, let's say, at point X.

Obviously, there is no impedance match between the generator and the L/C circuit between 6SK7 grid and ground. But—and this is the whole story—the circuits being aligned are separated from the generator by the tube, a 6SK7, which stands between generator and 6SQ7. Therefore, when alignment is properly done, there is impedance matching.

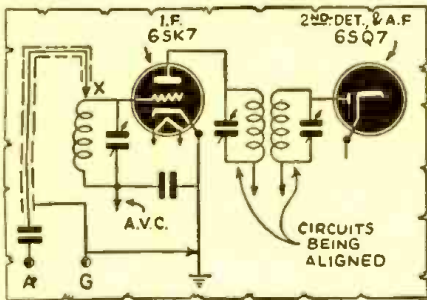

Let's take the 2nd part of the above-mentioned statement by Buck, namely, "signal strength is not like that of a broadcast station." Buck, himself, tells you to align with a weak signal image, which is, in character, like that of the signal generator, since the generator is always properly set for low output. The difference between the signal generator and the station is one of modulation (generator, generally 400 cycles; station, of whatever audio happens to be momentarily impressed on the originating microphone in the studio). At any rate, this statement is meaningless and not connected with alignment at all. "The oscillator is certainly not like the radio's own antenna . . ."

But, why go on? The more I try to keep my temper, the more I burn up, and you, Mr. Editor, surprise me that you publish such tripe. For God's sake when are you going to start slanting your magazine policy towards the intelligent and technically-trained section of the radio trade? Isn't it plain that the men with the money and ability to buy are going to be the men with education, at least a high school education, and that the others have no place in radio? What we should have is an organization comparable to that of the radio engineering or other professions, and build up public esteem for the Serviceman, driving out all of the incompetents. As a requirement for admission to the Radio Service Guild, a man would have to pass a stiff examination in fundamentals and service technique. He would then receive a certificate of merit and be entitled to use the letters, R.S.G. after his name. How about you and the editors of all the other nationally-known magazines collaborating in a concerted, serious effort to better the status of the professional radio Serviceman having the necessary education and experience? Beginners, apprentices, could receive a junior membership. Such a plan would ultimately better the entire industry, since a better grade of man would be attracted to Radio and carve out a career for himself that

would permit recognition of his ability and at the same time ensure his chances of making a good livelihood. Action!

WILLARD MOODY,
New York, N. Y.

**A. C. SHANEY'S SOUND
ARTICLES**

Dear Editor:

I have been a subscriber to your magazine for several years and have constructed several radio sets which were described from time to time with good results in all cases.

However I am beginning to get disgusted with your section on amplifiers. It seems as though—rather than helping one construct a good amplifier you get one enthused in an article from a description of a good amplifier and about the time when all the good qualities of the amplifier are given and one is looking forward to the parts list and the construction details, the article closes with "Courtesy of Amplifier Co. of America."

In other words your articles seem to be only advertisements for this company with no intentions of helping one build an amplifier for enough information is omitted from the diagram to discourage one from trying to build one without further construction details.

I had been hoping that you would give construction details on about a 30-watt high-fidelity amplifier with volume expansion but in two articles—Oct. 1939 "All-Push-Pull Direct-Coupled Amplifier" and July 1940 issue—you have described such an amplifier but in the end it is only advertisement for a factory-built job with no intention of helping your readers build it. This can be easily shown by the fact that I asked you for the parts list of both amplifiers and I did not receive even a reply.

Do you intend to publish anything in the near future on how to build a good amplifier or are they all going to continue as in the past—only advertisements for a factory-built job? I think that if you will investigate you will find that a good many of your readers think as I do about your articles on amplifiers. As to your sections on radio, etc., I have no complaints to make for one can generally start building one with confidence for enough information is given, and I hope that you will soon have all the necessary construction details on the amplifiers which are described from time to time. I shall also appreciate the construction details and parts list for the above-mentioned amplifiers if you have them or can get them for me or the parts list and construction details for a similar amplifier.

ELLSWORTH DODRILL,
O'Neill, Nebr.

Mr. Shaney's articles in *Radio-Craft* may be broadly classified in two groups, one being of an educational nature, wherein the newest developments in commercial laboratories are made available to readers of *Radio-Craft*.

Although it is not the intention of many sound companies to *always* enable the construction of these new items by its readers, those who have sufficient technical knowledge and training should have no difficulty in constructing some of the advanced developments.

On the other hand, all articles which are written with the idea of being constructed by readers, are usually accompanied by a complete parts list, or in many cases, sufficient information is given in the circuit diagram to enable an average technician to select the correct parts.

The disadvantage in supplying a parts

**Conclusive
Testing**



TRIPLET MODEL 1213

\$22.00 Dealer
Net Price

- Exclusive Handy Hinged Post-card Reference Tube Chart
- Filament Voltages from 1.1 to 110
- RED • DOT Lifetime Guaranteed Instrument
- Neon Shorts Test

Model 1213 contains all sockets to test all present day tubes including Pilot Lamps and Gaseous Rectifiers. Ballast Tube Continuity Test . . . Has separate line voltage control meter . . . Housed in snappy appearing metal case with brown suede baked enamel finish. Three-tone panel is brown, tan and red with silver markings.

Dealer Net Price **\$22.00**

MODEL 1620

This is a counter type, lever switch operated tube tester. Four "quick change" non-obsolete features, including RED • DOT Lifetime Guaranteed Instrument. Speed Roll Chart, New socket panel and Switching Section can all be replaced should unanticipated changes make it necessary.



Dealer Net Price **\$37.84**

MODEL 1621—Similar to Model 1620, but contained in smaller, more portable case . . . Dealer Net Price **\$34.84**

Write for Catalog—Section 165 Harmon Avenue

TRIPLET ELECTRICAL INSTRUMENT CO.
Bluffton, Ohio

RADIO TRAINING



PORT ARTHUR COLLEGE—not privately owned, not operated for profit, a college built and endowed by the late capitalist-philanthropist, John W. Gates—offers the most thorough practical Radio training in America. P. A. C. owns Radio Station KPAC, which is equipped with the very latest type 1000-Watt high fidelity RCA transmitter, operating on 1220 kc. with directional antenna system. The college is authorized to teach RCA texts.

The Radio training covers thoroughly Airways, Press, Announcing, Teletype, Type-writing, Laboratory and practical experience at KPAC transmitter, control room and studios. Announcing is an optional part of this training; nevertheless a number of students annually make successful announcers. Port Arthur College pioneered the teaching of radio with its first classes in 1909, and for thirty-one years has maintained an active Employment Bureau that is successful in placing graduates in airways, broadcast and marine radio industries.

If interested in details about the Radio Course, write for Bulletin R-41

PORT ARTHUR COLLEGE
PORT ARTHUR (World-Known Port)
TEXAS

RADIO DIAGRAMS

MOST - OFTEN - NEEDED

MOST OFTEN-NEEDED RADIO DIAGRAMS

ALL MAKES 1926-1938
 In this one low-priced manual you have all the circuits you really need. 427 diagrams of most-often serviced radios is the help you want for easier, faster, and better repairs. You will find 4 out of 5 diagrams needed in this manual. 244 pages, large 8½x11 in. size. Special price **\$1.95**

4 OUT OF 5 CIRCUITS YOU NEED

HOW TO SAVE TIME
 Service hints, diagrams, alignment data, test charts, and parts lists included will prove time-savers and money-makers for you. Get these handy "on-the-job" handbooks. No need to work blind-folded. The time saved in two days will more than pay for these manuals.

MOST POPULAR 1940 RADIO DIAGRAMS

1939-1940 DIAGRAMS
 This single manual will give you over 80% of all 1939-40 circuits ever needed, acquaint you with recent radio developments, and teach you how to service quickly millions of sets sold last year. Models of 43 manufacturers. 212 large pages, 8½x11 inches. Limited quantity at **\$4.50**

FREE EXAMINATION

SUPREME PUBLICATIONS, Room 845
 3727 W. 13th St., Chicago, Illinois
 Ship the manuals checked, all must be satisfied or you will refund my money in full.
 Most Often-Needed Diagrams, 1926-1938, @ \$1.95
 Most Popular 1940 Radio Diagrams, @ \$1.50
 I am enclosing \$..... send postpaid
 Send C.O.D. I will pay the mailman.
 NAME.....
 (Write address below and send this corner)

list furnished by a sound company, is that actual company names are specified, and this is really unfair both to the readers and to the suppliers, because a 0.1-mf. condenser need not necessarily be of any specific manufacture in order to work correctly in a circuit involving its use. It is therefore obvious that if a condenser is indicated in the circuit diagram, an itemized parts list is really unnecessary.

It is to be further stressed that readers should not attempt to construct items which exceed their abilities and facilities.

The specific circuit diagram which Mr. Dodrill refers to, namely the 30-Watt Direct-Coupled Amplifier with Expander and Suppressor, was completely indicated in the November, 1939 issue of *Radio-Craft*, Page 268. Every value has been carefully indicated, and any radio technician should be able to construct this unit without a List of Parts.

There are occasions, where sound companies can not give any technical information because of extensive laboratory work in obtaining this data, but this, as far as we can recall, has come up very rarely. The only specific instance that we know of has been in the design of the Amplifier Company of America "Audio Spectrum" unit, which we are sure no reader can condemn them for not giving complete detailed data on.—*The Editors*

FROM A SPUNKY ENGLISH READER

Dear Editor:

As a newsstand reader of your journal and a radio technician since early 1929, I hope a few words from me will be welcome.

Since the "streamlining" of your paper it has been a pleasure to refer to any particular section; also, it has made the indexing of subjects much quicker. Thanks for the innovation.

Since our national preoccupation with a continental affair (still in progress) radio has been a little bit difficult to keep pace with and the arrival of *Radio-Craft* even a little late is a Godsend.

Some 4 years ago I started a reference library of American textbooks. This has received the marked attention of one of the recent continental visitors and is now blown to bits.

I am now negotiating with the authorities here to obtain an import license for a small but necessary part of the destroyed texts.*

There are other and more weighty texts but they are not so essential to me, and I can defer to some later date the ordering of them.

Some American components are still obtainable here though the manufacturers are not giving us all the help in publicizing that they could. *Radio-Craft* has been of great value in this connection.

May I make a plea to Hammarlund, Supreme, Readrite, Raytheon, and all the others?: "Send us the dope on your products, we want to know about them and use them." Now for a few personal notes.

Thanks, Mr. Shaney, yours is one of the best sections in an excellent assembly. Keep it up. Give us the dope on all the newer variations of *direct-coupled amplifiers*.

Thanks, Mr. Sprayberry. The circuit analyses are great and keep us in touch with the latest phases in radio. No journal here does it.

Thanks, Mr. Editor & Co., for the new *Radio-Craft*. It will always find a welcome and honoured place on the bench and in the bookshelf.

*A tube data-book, and the Amplifier Handbook and Public Address Guide.—*Editor*

To the great gang of readers in the States may I say—"Howdy, fellows, if you can spare a minute from *Radio-Craft* the address for mail is still that given at the end of this letter (send your letters care of *Radio-Craft*, we will forward.—*Editor*) so let's be hearin'!" (Continental visitors to England please DON'T note.)

My respects to you, Mr. Editor.
 THOMAS CLARKE,
 Sheffield, England

V.-T. VOLTMETER PROBLEM

Dear Editor:

As a regular reader of your magazine, I am submitting to you free of charge (thanks —*Ed.*) the solution of a problem that is baffling many Servicemen who have built or are building V.-T. Vm.s employing a so-called *bucking circuit* in the plate circuit of the final stage, to balance-out plate current that might flow through these meters at no signal input at the grid.

Quite often, low-range microammeters are used and the erroneous impression seems to have gotten about (even in Terman's "Radio Engineering" textbook [1st Edition, 8th impression, 1932]) among many that at this balance condition, 2 currents, equal in magnitude, but opposing, give a zero meter reading, but that the coil of the meter is carrying the arithmetical sum of these currents which may reach a very high value and as a consequence the meter may be burned-out although registering zero current!

However, a simple example will show that the potential across the meter coil is zero, as well as the reading of the current, and the current through the coil, when balance is attained. A simple bucking circuit is shown, together with an accompanying simplification diagram.

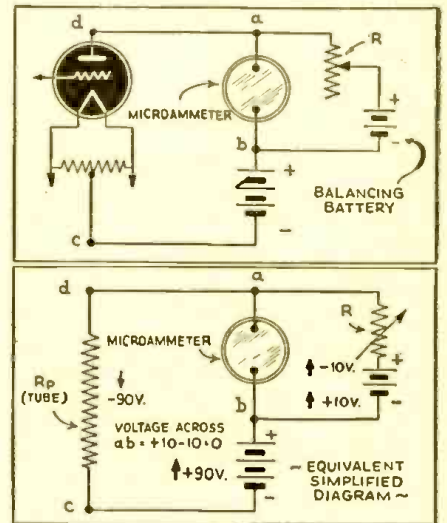

The arrows show current flow, and that at correct choice of R the voltage across a-b is zero and that the main battery supply voltage appears at c-d. Any increase in current due to signal application on the grid (rectified or otherwise) will then show as an upward reading on a current meter connected across a-b.

I believe this exposition will bring out to your readers the following:

- (1) Correction of certain erroneous ideas widespread about this connection, found even in textbooks and periodicals.
- (2) The theory of the bucking circuit, and why it increases the sensitivity and usable range of the meter.
- (3) That current flowing from positive to negative in a battery is considered a posi-

tive voltage, one from negative to positive is a negative voltage, etc., through resistors.

FRANK P. DEFINA,
Hazelton, Pa.

MR. RUSSELL RETORTS

Dear Editor:

I hope this will clear up some of the confusion in the "Regarding Hearing-Aids" in the Mailbag, which must be something to any interested bystanders, who have read both Mr. Cisin's letter and mine.

About 16 letters have been received by me from hard-of-hearing people, requesting more information and all have the same complaint; not sufficient power in the devices they have tried. I didn't reply, that they were stone deaf and could not hear if they put their ear in a 10-watt speaker. But tried to explain that so many designers did not have a proper understanding of the requirements of the hard-of-hearing and that the more noise we made about it the better.

In fairness to Mr. Cisin, let me say that the amplifier he described in "R.-C." was not primarily designed for a hearing-aid, but was in a class by itself for that work and quote from the article: "The subject of the test was a person who depended upon lip reading, due to the inability of ordinary hearing-aids to give relief. Without the instrument, one could get behind this near-deaf person and shout as loudly as possible without being heard. With this amplifier, however, the hard-of-hearing person was able to hear and understand every word spoken behind his back . . . in a normal tone of voice." Would not that lead a person who could hear shouting behind his back, to believe that the instrument was worth constructing?

Yes, I knew the 1S4 tube is rated at 0.065-watt, but there was the author's statement: "It was in a class by itself." The copy I made of the instrument had all of the pick-up or sensitivity that was claimed for it. A person with normal hearing could hear a watch tick a foot away and more. I have no quarrel with Mr. Cisin and no doubt he will be out soon with a real power amplifier that will help us all.

Me—? I am just faintly amusing and very ignorant, qualified only to write gems of stupidity. However I do know that if you depend entirely upon voltage amplification to make people hear, who cannot get results with ordinary 'aids, it will take so much that they will look like the fellow in the electrical show displaying the Tesla coil. How about a little of both, enough to give fair pick-up and a power output that will really tickle the old mastoid bone on full volume? Then there will be enough output for these days of head colds, and for the future if the deafness is progressive.

One of that power brings up the question of size. I stated in my first letter that lots of people could get a small device, hide it, and nobody would ever know they were deaf. "Easy to conceal" is a standard statement with the manufacturers. This to my moronic mind is silly. Even "stone" deafness is not as dishonorable as Mr. Cisin would have us believe and it is not always accompanied by stupidity as in my case. If you are hard-of-hearing the sooner those you contact know it the better. They will soon detect your infirmity anyway. The smaller the instrument the better, of course; my point was not to sacrifice efficiency and power for size.

As to the medical profession, I still say, that if you want to get wired for sound let the radio men do it. It won't cost you a cent if they can't make you hear.

As to crystals—a carbon mike worked

**BOY OH BOY—
IS THIS GIVING IT AWAY!**

NOW ONLY
\$76.95
LESS SPEAKER
—Was \$115.50



HALLICRAFTERS "TWENTY-THREE"

PRICES cut to the bone on Nationally Known Radio Supplies during this Spring Clearance of Demonstrators, guaranteed 1940 models and brand new surplus stock of Nationally known short wave receivers, ham gear and radio service instruments. Your chance to get highest quality radio needs at practically your own price.

Imagine this famous Hallicrafter 23 that formerly sold for \$115.50 less speaker—now only \$76.95! Current model—guaranteed! Saving of one-third! Complete with tubes and crystal—Speaker \$12.00 extra. Compensated frequency stability, eliminating drift. Accurate reset band spread system. No bandset dial to fuss with. Stations always come in at same place on dial. Shipping weight, 56 lbs.

57TC08816—Cash Price \$76.95
All these bargains available on Easy Terms—write for details.

Write for our folder showing merchandise and equipment included in this sale. Ask for Folder No. RC6578M. Also get our new Ham and Service Supply Catalog No. RC717M and our complete PA Catalog No. RC732M.

We have a Very Limited Number of National 1940 Model NC-80X and NC-81X Receivers priced low for immediate clearance.



Many items of popular and current model Test Instruments also included in this Bargain Festival. Take advantage of this once-in-a-lifetime opportunity—ACT NOW!

SEARS, ROEBUCK AND CO., CHICAGO, ILL.

much better for me with the amplifier I had reference to, where it is mounted on one end of the box close to the hot metal tubes, and due to its high level the volume control need not be turned up much. Somehow, these amplifiers just worked better that way. Oh, I knew there would be a squawk there. For most other work crystal mikes have "it."

About earphones—I have had several crystals. They just won't stand up. And if you leave them in the window where bright sunlight filters through, heating them up, it is goodbye \$12 (if of the ear-insert type).

In closing, let me say that in designing an amplifier for hearing-aid work the object is to hear, and then establish whatever voltage amplification is required to give the necessary pick-up; and NEVER the other way around, as so many think.

Radio-Craft has done us fellows a real service and I hope to see more hearing-aid

dope in the future. Come on, Mr. Cisin, don't sulk—give us a real power job soon.

EARL RUSSELL,
Celfax, Ill.

V.-T. VOLTMETER TROUBLE

Dear Editor:

I have built the Vacuum-Tube Voltmeter described by R. C. Turner in the June, 1940, issue of Radio-Craft.

The instrument is very accurate on D.C. measurements. However, on A.C., the meter does not measure peak voltages correctly. For instance, when an accurate A.C. voltmeter indicates 112 volts r.m.s., the vacuum-tube voltmeter shows a peak voltage of 1.8 which should read about 3.6 or 157.92 volts on the 0-500 V. scale. On the 0-100 V. scale, the reading is 8.1, whereas the needle should go beyond the "100" on the scale indefinitely.



LEARN RADIO

SERVICING COURSE—8 WEEKS
OPERATING INCLUDES SERVICING **—5 MONTHS**

H. C. Lewis

I'LL FINANCE YOUR TRAINING
Mail coupon today for free book showing how you can learn Radio Operating, Servicing, Sound and Television in a few short weeks in Coyne Shops and also how you can pay tuition in easy monthly payments after graduation.

LEARN BY DOING
On real Radio receiving and transmitting equipment at Coyne. Simple, easy method of practical shop training. You don't need previous experience. Prepare for Radio Operators' Government license Exam, and for good jobs in Broadcast, Police Radio, Aircraft Radio, Ships, Commercial Radio stations, or in service shops and radio factories. "Learn by doing", the quick, modern way, at Coyne Shops in Chicago.

EARN WHILE LEARNING
Job Help After Graduation
We assist you in getting part-time work to help pay living expenses and give you real employment service after you graduate.

H. C. LEWIS, Pres., COYNE RADIO SCHOOL,
500 So. Paulina St., Dept. 51-84, Chicago, Ill.

Please send me your free book and details of easy Pay-After-Graduation Plan.

NAME _____
ADDRESS _____
CITY _____ STATE _____

POWER AND LIGHT



ONAN A.C. ELECTRIC PLANTS supply current for Radios, Transmitters and Receivers, P. A. Systems, Movie Projectors, Sound Truck Apparatus, Tools, Lights. All Appliances Used as Stand-by Equipment in Schools, Hospitals, Theaters and Public Buildings in case of Power Line Failure due to Storms, Floods, etc. Available in 110 or 220 Volt A.C.—12, 32 and 110 Volt D.C.—Also Dual Voltage A.C.—D.C. Types. Manual, Pull-Automatic & Self-Starting. \$99 and up. Shipped. Ready to Run.

D. W. ONAN & SONS
721 Reyaisten Avenue, Minneapolis, Minn.

RADIO TECHNOLOGY



RCA Institutes offer an intensive course of high standard embracing all phases of Radio and Television. Practical training with modern equipment at New York and Chicago schools. Also specialized courses in Aviation Communications, Radio Servicing and Commercial Operating. Catalog Dept. RC-41.

RCA INSTITUTES, Inc.
A Radio Corporation of America Service
75 Varick St., New York, 1154 Merchandise Mart, Chicago

RADIO-TELEVISION

Oldest, largest Radio-Television school in West trains you for good pay job. Complete instruction including Radio Construction and Service, Broadcast Operating, Sound, Talking Pictures, Television, Public Address, etc. Flexible plan to meet specific needs of those with or without jobs. Transportation allowed to L.A. Earn room and board while learning. Request Free Catalog.

NATIONAL SCHOOLS, Dept. 5-RC
Los Angeles

Are You The Man For The Job?

Every radioman has the opportunity today to advance himself to a better radio job. With wide-spread expansion programs there comes a need for men with modern technical training. CREI home study training is the proven way to more money—"5,000 other radiomen can't be wrong!"

WRITE FOR FREE BOOKLET, CAPITOL RADIO ENGINEERING INSTITUTE, Dept. RC-5, 3224 16th St., N.W., Washington, D. C.

Correspondence Courses in
RADIO and ELECTRICAL ENGINEERING

ELECTRICAL ENGINEERING Get good grasp of wide electrical field. Prepare yourself, at Low Cost, for secure future. Modern, simplified. You can understand quickly.

RADIO ENGINEERING Extra fine course in radio, public address, photo-electric work. Trains you to be super-service man, real vacuum tube technician. Experi. kits furnished. Diploma on completion. Tuition, \$25, either course. Deferred payment plan.

FREE Get copies of school catalogs, student magazines, complete details. **SEND NOW!**

LINCOLN ENGINEERING SCHOOL, Box 931-629, LINCOLN, NEBR.

What would you suggest I do to make the meter read peak volts correctly?

I like Radio-Craft very much and it is a fine magazine for the radio Serviceman. I am hoping that the March, 1941, issue will give some valuable information on the vacuum-tube voltmeter. (*)

STANTON N. DRUMMOND,
North Western, N. Y.

*Mr. Drummond, when he wrote, had in mind a notice, which had appeared in the preceding issue, on "Vacuum-Tube Voltmeters—Theory and Practice."

This letter was forwarded to the author whose reply follows:
Dear Mr. Drummond:

You state that you have had difficulty in measuring the peak value of a 112-volt r.m.s. potential with the vacuum-tube voltmeter I described in the June, 1940 issue of Radio-Craft. It is presumed that you mean by this that you have attempted to measure the voltage of the same A.C. line that supplies the instrument.

The vacuum-tube voltmeter shown in my article cannot be used for such a purpose because of the two 0.1-mf. line bypass condensers, C6 and C7. These condensers place the negative return (chassis) effectively at the center of the line voltage, giving rise to the error you have noticed. If 112 volts from a separate source, such as a transformer secondary, be applied to the A.C. meter terminals, you will find the correct peak value—approximately 157 volts—indicated.

Please do not hesitate to call upon me for any further information.

RUFUS P. TURNER, W1AY

YEP . . . HEARING-AIDS AGAIN!

Dear Editor:

I've been afraid of making the enclosed (below—Ed.) too long for you, but hope you may find some of it interesting enough to get at least part of it in. I belong to a discussion group of hard-of-hearing people who have been trying to talk out some of these hearing-aid problems by mail, and I subscribed to Radio-Craft purely because of the hearing-aid articles you occasionally publish. (Italics ours—Ed.) I hope you will continue to publish them in as much space as you feel you can afford to give over to such a topic.

The hearing-aid people have done wonders, really, considering the difficulties and what they have done it with, yet some of the facts known in the laboratories, but little known outside, prove that even now they are not always following the best methods, but the ones most profitable at the moment. Selling hearing-aids by present sales methods is a very expensive proposition, and this has to be taken into consideration.

M. B. K.

Dear Editor:

This hearing-aid argument is getting interesting! After about 20 years' study of what little I as a layman could learn about hearing-aids and the physical aspects of deafness, I'd call both Mr. Cisin and Mr. Russell right, but in different ways.

Mr. Cisin's argument sounds like the dope of some of the hearing-aid men—men who know a lot about technicalities and theory but have been blundering around in the dark trying to find out about practical hearing. There's still a wide gulf sometimes between theory and practice.

Mr. Cisin's reference to the deaf leading the deaf sounds like a cousin to a story, coming straight from one of the salesmen, of the sales manager of a large hearing-aid

firm telling his convened salesmen that: "You cannot talk to the hard-of-hearing as you would to a normal person, because the hard-of-hearing are not normal mentally. They are just like children; you have to give them a line that will impress them, but don't EVER answer any of their questions. They really don't want to know the truth, but just ask questions to annoy you." Phooey from me to all such. Among the hard-of-hearing I know of are not only radio men but also electrical engineers, several of the biggest men in electrical and radio history, ear doctors, educators, and the heads of several of the most progressive hearing-aid firms. The qualified deafened man would be my choice to lead me any day in preference to a hearing man.

The plain fact is that the hard-of-hearing person needs greater—sometimes much greater—volume than the normal person, and whether you call it voltage amplification or power amplification is immaterial to the average person who doesn't know either from Adam. I know of at least one hearing-aid firm that failed because of not realizing how much greater volume most hard-of-hearing persons need. Some technicians give too much attention to non-essentials and too little to what is very much essential. Once a hearing-aid firm's newly-employed engineer took a look at the firm's old -aid and said, "The sound goes in front there, but where does it come out?" And so he designed a new microphone case for an old microphone they had been using for half-a-dozen years, and put openings all around the sides of it. The sound, Mr. Engineer, comes out exactly where it comes out of your ear.

For Mr. Cisin's information, the crystal microphone has too low an output to enable a very seriously deafened person to get enough volume (yes, we are talking of volume, Mr. Cisin) from as conveniently-sized amplifiers as the carbon microphone does. And crystal earphones cannot tolerate, and from some amplifiers cannot even deliver, the high volume that magnetic earphones can. I've proved this to my sorrow by having 3 pairs and 2 single crystal phones break down under the load I have had to put on them.

But for persons whose hearing is not too seriously impaired Mr. Cisin is right that crystal mikes and earpieces are sometimes, but not always, more satisfactory than carbon mikes and magnetic earpieces. But his amplifier's enabling a person to hear the ticking of a watch at over one foot is no satisfactory test, and no test he could report would be worth a hill of beans unless at the same time he reported the number of decibels of hearing the subject had lost.

My numerous and widely-spread deafened acquaintances, and I, know quite a number of doctors who don't know the first point about a hearing-aid and many of them don't know as much about the physics of hearing as some of us who have studied the problem from a profound interest born of our affliction. And those who do think they know something and are testing hearing and prescribing -aids are failing in many cases and don't realize that the reason is simply because the present method of testing is not scientifically applicable to prescribing even a hearing-aid of perfectly-controlled characteristics (and none of them yet have perfectly-controlled characteristics).

Tests are made of the audibility threshold of hearing, or what is lost, when what is needed is a complete measurement of the hearing sensation area that remains, and its peculiarities. (*) Several of our foremost physicists who have worked on the problem agree on this. Yet the hearing-aid people

have refused for years to put into practice some of the other suggestions of such physicists.

The profoundly deafened who still have some usable hearing have received little practical attention from the hearing-aid people. I'd like to plead for them, but I know there is no profit in such cases, and they are difficult. I happen to know of 4 such people who said they could not get service from any 'aid offered them, and happening to have the ability to do so they set out and built their own 'aids. One of them is an electrical engineer with experience in a well-known physics laboratory, and another is now selling his 'aids to the public and has been quoted in this magazine. Yes, let the deaf lead the deaf, and they might also lead Mr. Cisin to a clearer understanding of such cases.

MARTIN B. KEFFER,
Roanoke, Va.

*See "How Do We Hear?", Part I, *Radio-Craft*, May 1936, and Part II, June.—Editor

SERVICEMAN TYRO

Dear Editor:

After looking over past issues of your magazine, I am convinced that your publication is improving from month to month. I have found the Classified Radio Directory very helpful. All the radio service articles are very helpful.

If possible, please try to publish a few more articles on how to obtain more radio business. You surely must have some suggestions along this line. How about some sales letters, or say a complete advertising campaign. I already have your booklet, "Breaking into the Radio Service Business." All in all, you have a very fine magazine.

PAUL T. BAUMAN,
St. Cloud, Minn.

Thank you, Mr. Bauman, for your kind comments. We will be glad to consider for publication in *Radio-Craft* any article, along this line, which meet our usual requirements of reader interest, etc.—Editor

RE: "ALIGNING SUPERHETS."

Dear Editor:

After reading Homer C. Buck's article in the January, 1941 issue of *Radio-Craft*, entitled "Aligning Superheterodyne Receivers," I was wondering if he will ever get to realize how wrong his method of superheterodyne alignment is. To make sure that he will realize just that, I went to the trouble of writing this letter.

I don't care how many sets he, himself, ruins with his method of alignment because that is his problem. But the fact that he misleads other radiomen and influences them to use the wrong method of alignment clamors for protest.

His method of superheterodyne alignment is correct only in case the oscillator is correctly aligned. Since this is rarely the case, his method is rarely correct. His method is based on the assumption that between 1,500 kc. and 588 kc. on the dial there is a change in the oscillator frequency of 912 kc., or twice the I.F. (456 kc.), which is true only in case the I.F. is 456 kc. But since the I.F. is the thing he is looking for, what makes him think he will ever hit 456 kc. using his method, when he hasn't the slightest idea about the oscillator frequency adjustment?

Let us take a practical example. Suppose the receiver has been mistuned so that its I.F. is 440 kc. instead of 456, but that he doesn't know about it. Also suppose that the oscillator frequency has been mistuned so that WJBK now comes in at 1,500 kc.

(on the dial), and its image at 588 kc.; which is possible since the oscillator may be completely mistuned by virtue of its 2-point adjustment. Now he goes about aligning the receiver with his favorite method. He puts the dial pointer at 588 kc. and adjusts the I.F. trimmers for maximum output of the image frequency of WJBK. This procedure results in a perfect alignment of the intermediate frequency to 440 kc. From now on no matter what else he does to the receiver, he will get WJBK exactly at 1,500 kc., its image at 588 kc. (on the dial) and everything else will be slightly off, and sometimes more than just slightly. The difference in the oscillator frequency between 588 kc. and 1,500 kc. on the dial is now going to be 880 kc. instead of 912. I hope I need not tell him what will happen to the sensitivity and selectivity of the set, and its inclination to image frequency whistles on the lower end of the dial, since the R.F. circuit lost its selectivity.

The trouble with Mr. Buck is that he tried to solve a problem having two variables when one of them should be known. He should know that whenever there is a problem with two variables, one dependent upon the other, we can get a single-valued answer for one variable, only if we accept a definite value for the other variable. In the case of superheterodyne alignment we must accept a definite frequency for the I.F. supplied by a reliable signal generator.

The aligning procedure gets more painful and the accuracy more doubtful if he tries to align the set by tuning to a direct signal instead of its image.

I think he would be better off using a reliable signal generator for all his alignments, and checking up on its frequency from time to time by beating its signal with some signal on the standard broadcast band to make sure its frequency hasn't changed.

Please forgive my frankness.

JOEL JULIE,
New York, N. Y.

PUTS MOODY ON THE CARPET

Dear Editor:

In regard to Mr. Willard Moody in *Radio-Craft* for Feb. '41, page 452, he may be serious, he may not; one thing is sure, he is not consistent—he does not approve of "letters from readers." I wonder how he would have had a chance to advise the Editor, and let the world see and know that he did give such advice, if the Editor had not given space for "letters from readers."

For one of the many readers, the writer wishes to thank the Editor for that privilege. The letter of Mr. Earl Russell "Regarding Hearing-Aids" was certainly appreciated as I am in the same boat with Mr. Russell, and got a lot of information that would have been missed if there had not been any "letters from the readers."

After all, it is their magazine—a magazine for all the readers, "not just one"; and what a privilege to know what others think and do who have had experience. Experience, what a costly school! And to profit from the experience of the readers of this magazine, what a favor!

That goes for the Editorials of Mr. Hugo Gernsback, a Radio pioneer; no doubt, it must go over the head of a novice, a tyro, but I take it for granted all kinds of Radio men read "R.-C."—engineers, those interested in Electrotechnics, inventors, etc.—must derive a lot of hints and suggestions for further development in the science of Radio.

There are other points of disagreement with Mr. Moody, but this will take too much space, and no doubt, others will register their opposition to some of the advices.

HENRY LOUIS TRUDEAU,
Danielson, Conn.

New Direct-Coupled FM - AM

AMPLIFIER MANUAL

By A. C. SHANEY

Chief Engineer, Amplifier Co. of America



For the Layman, Serviceman
Recordist and Engineer

Regardless of whether you are interested in the finest type of phonograph reproduction, high fidelity recording, sound-on-film applications, FM or AM programs, you will find invaluable information in this practical handbook. Written by the leading exponent of direct-coupled amplifiers who has spent more than 10 years improving and perfecting the famous Lotrin-White circuit.

Explains the theory and practical application of:

- Variable Speed Non-Overloading Push-Pull Expansion
- Non-Frequency Discriminating Scratch Suppression
- Push-Pull Balanced Direct-Coupled Amplification
- Push-Pull High-Frequency Equalization
- Push-Pull Low-Frequency Equalization
- Push-Pull Volume Compression
- Automatic Volume Limitation
- Automatic Volume Control
- Calibrated V.U. Indicator
- Audio Spectrum Control
- Remote Control

If you are interested in the latest audio developments, you can't afford to be without this complete compilation of authentic articles on Direct-Coupled Amplifiers. 32 pages 8 1/2" x 11". Over 100 diagrams and illustrations.

Priced to Cover Cost of 20c
Printing and Mailing

Send Stamps or Coin

AMPLIFIER CO. of AMERICA

17 WEST 20TH STREET. NEW YORK, N. Y.

EVERYTHING IN RADIO

RADIO
1941 CATALOG
1000 PAGES
FREE ADDRESS
LISTS
RECENT
EXCITING
BURSTEIN-APPLEBEE CO.

This one big book serves your entire radio needs. It includes sets, parts and supplies, public address systems, amateur equipment, test kits and fluorescent lighting. You'll find the nationally known favorites at the lowest possible prices. Get your copy of this big FREE CATALOG today.

BIG FREE CATALOG

BURSTEIN-APPLEBEE COMPANY

1012-14 MCGEE STREET, KANSAS CITY, MISSOURI

RADIO OPERATORS

WANTED

The National Defense Program is creating innumerable openings for Commercial Radio Operators—Now is the time to capitalize on your radio training and experience by obtaining a Commercial Radio Operator's License and taking advantage of the many opportunities presented. My recent publication "RADIO OPERATORS' LICENSE GUIDE" has been especially prepared as a Guide for those radio men having the necessary training and experience but who are unaware of the exact requirements for a Commercial Radio Operator's License—Containing over 1,250 questions and answers to the new type examinations, it will enable you to successfully pass the examinations.

Only \$3.00 Postpaid—Send check or Money Order.

WAYNE MILLER

205 West Wacker Drive
Chicago, Illinois

"I guarantee you the best deal!"

HARRISON • RADIO • COMPANY
 • 12 WEST BROADWAY • NEW YORK CITY

Dear Friend:

If you are going to buy a Communications Receiver or other Radio Equipment, every word of this letter is of importance to you. I am an Authorized Distributor of all Amateur apparatus, and can supply you with everything you need. I deal direct with every manufacturer and can give you the latest and best at lowest prices. I have one of the most complete stocks in the country. My prompt delivery service, very liberal trade-in allowances, easiest and simplest time payment terms, and my personal attention to your every wish is sure to please you!

I have all available latest model Hallicrafters, Hammarlund, RME, National, RCA, Howard, Echophone, etc, receivers in my stock for immediate shipment. (From the factory if you prefer) You need send only a \$5.00 deposit with your order. Try it for ten days and if you don't like the receiver your money will be returned. Also all Hallicrafters, National, Thordarson, Abbott, RTL, UTC, Stancor, etc, Transmitters and Kits are offered. We wire and test kits in our Shop at reasonable rates.

You can buy everything from me on my easier credit terms for your convenience. Receivers, Transmitters, Kits, etc. Down payment can be as little as 10% of the cash price. The balance in easy monthly payments. Your entire cost for credit is only 6% on the balance. The larger your down payment, the smaller your interest.

I take your old receiver or transmitter in trade. Tell me make, model, age, and condition. Also mention what allowance you feel would be fair to us both.

I also buy modern transmitters, receivers, and complete stations for cash. I always have some good values in reconditioned equipment. It will pay you to communicate with me.

Send to me for prompt delivery of any item you see in any catalog or advertisement at the lowest price shown. I know you'll like doing business with me because I really want every one of my customers to be completely satisfied. Send me your orders; you, too, can depend upon my fullest cooperation and help. I want you to be my customer and friend, and I promise to always give you the very fairest and squarest deal.

Sincerely yours,

73

Bill Harrison

W2AVA

HARRISON HAS IT!

SHORT WAVE SPECIALISTS SINCE 1928

EVERYTHING IN RADIO ELECTRICAL AND ELECTRONIC EQUIPMENT

TELEPHONE WORTH 2-2728



proved Sky Buddy del S-19-R \$29.50

HIGHEST TRADE-IN ALLOWANCES



Traveler S-29 \$59.50

EASIEST TERMS

10 DAY FREE TRIAL



Sky Champ Model S-20-R



NEW 1941 Super Skyrider Model SX-28 \$159.50

hallicrafters receivers
 + Harrison Service
 = Your complete satisfaction

"Order your Receiver today — from me!"

RADIO-CRAFT

“RADIO'S GREATEST MAGAZINE”

. . . . *Eternal Vigilance
must be our watchword
against radio subversion*

RADIOBOTAGE

By the Editor — HUGO GERNSBACK

It is a well-known fact that history tends to repeat itself in more ways than one. Right now we find ourselves again in a similar position to that in 1915 when we were not at war with Germany—yet German agents were active to the detriment of the country then, as they are now.

Prior to World War I, the then German Imperial Government had planted on these shores a number of radio stations which ostensibly were for commercial purposes only, but were later proven to be violating the laws of this country by committing unneutral acts against the United States.

The United States, at that time, took over the German wireless stations at Tuckerton and Sayville, Long Island, to prevent unneutral messages from being sent to Germany.

In an Editorial, entitled, “Sayville,” in my former magazine, *The Electrical Experimenter* for August 1915, I took pains to show how masked and disguised messages could be sent out, violating our then neutrality. My reasoning was violently objected to by the head of the Sayville wireless station, the well-known Dr. K. G. Frank. For the record, I reprint elsewhere in this issue (*), the exchange of letters that took place at that time. The arguments set forth by Dr. K. G. Frank are exactly those used by present-day German officials; and the tone and attitude was the same in 1915, as it is in 1941. Dr. Frank was later proven to be the active United States head of the German Information Bureau (Secret Service)—now the *Gestapo*.

Through the vigilance of some self-appointed American investigators—old-time wireless operators—who made phonograph records of the Sayville transmissions at that time, the United States Government became convinced that the two stations were used for illegal purposes and promptly took them over.

In those days there was no broadcasting. All traffic had to go out via dots and dashes. The spoken word was not then broadcast. It should be noted that present subversive activities of the Axis Powers are much more thorough, less crude and infinitely more subtle. It is of paramount importance today that information regarding much of our defense activity should not reach the Axis Powers; the more delay that can be interposed to important news reaching the Axis, the better it will be for our welfare. *Information if it is to be of use at all, must be transmitted with reasonable speed.* As far as the United States and its geographical position is concerned, this can be accomplished nowadays only by means of cable, radio or telegraph. Technically, this country at this writing is not at war with the Axis, yet our defense activities are of terrific importance to the Axis partners. *Eternal vigilance* to keep information from going out, either by radio, cable or telegraph, must be the watchword from now on. Since the advent of radio broadcasting, conditions have changed and the “radioboteur”—the Fifth Columnist—who is active, will use the utmost ingenuity to get important information through. It should not take an Edgar Allan Poe to devise effective schemes as to how our radio broadcast stations can be misused to transmit such information. *which on the surface looks innocent enough.* It should always be borne in mind that the United States, at the present time, is wide open and it is comparatively easy to get vital information out of the country. To the North of us the chances are slim, because Canada being at war, probably stops most subversive intelligence. Our eastern and western coasts are not quite so safe, because radio transmitters placed at isolated points on our coasts can easily transmit short wave radio messages to Europe, or Asia, with outfits that can be placed in automobiles or trucks and moved about whenever necessary. That, of course, is the obvious thing, hence, the smart “radioboteur” will not use it, except when no other avenue is open. It is dangerous and will become more dangerous to foreign agents as time goes on. This will be made clearer below.

The hot spot in the United States, at the present time, is our southern border. Information can get across this border easily. It can even be telephoned or telegraphed to Mexico, thence cabled, or radioed, across the oceans if necessary. It is here where our Government will have to be more than careful and more than watchful, and it will be a task of the first magnitude to prevent messages from leaking out in this direction. While on the surface it looks hopeless, it is not quite as difficult as it might appear, because there

are several methods, which need not be discussed here, to effectively stop messages of this type.

There are other means whereby Fifth Columnists, and foreign agents, can disguise information in more subtle ways which are not immediately apparent. There are a number of foreign-language stations in this country, which to the writer's mind, should, at the present time, not be allowed to broadcast in such languages. I know I will be assailed vigorously on this point by those who operate such stations, but I insist that while they might have a purpose in peace times, they have no purpose at the present dangerous period through which we are passing.

You do not have to be a master of ingenuity to invent a number of simple and easily arranged codes which can be sent out over these—and for that matter any other broadcast station—by foreign agents who pose as entertainers. Popular songs, even ordinary music, can be arranged in such a way as to convey certain meanings. You have often witnessed the so-called “mind reading” performances where simple words or questions are asked by one performer, while the “mind reader” immediately tells you what object his partner has touched. Inflection of the voice, certain word combinations, etc., all can be made into effective codes. The same thing is true of music, whether it is a piano or violin solo. It can be done so effectively that even the owners of the station would not be aware of what is going on. What good you say, are such masked codes? Of tremendous importance, for the simple reason that a number of listeners can take down and decipher the code and then pass it on by radio, or by other means, over the border and across the oceans. You might say, “Why go to the trouble of doing all this?” “Why not use the cable or similar methods?” The point is that it is more difficult to do it by cable, because certain word combinations arouse suspicion, whereas radio broadcasts by voice, singing or instrumental music appear harmless and the perpetrators run less chance of apprehension.

We note, therefore, with great satisfaction that our Government, through the Federal Communications Commission, has set aside recently, \$1,600,000 to aid in national defense. Plans have been made for the establishment of listening posts to record, translate and analyze *foreign* shortwave broadcasts in this country. While records have been made before of foreign shortwave broadcasts for various Government agencies—Departments of State, Agriculture and Justice—the Government never had undertaken any study of them on a large scale. Now, for this purpose, the field service is adding about 40 trained men to its staffs at the stations from which the work will be carried on. These men, with the cooperation of the existing staffs, will now conduct a 24-hour watch to find and record programs which might be of interest. The records will be sent to Washington, where the headquarters and main staff of the new division will be located. Here a force of more than 300 technicians, translators, clerks, propaganda analysts and other experts will translate them into English and study them to determine their importance.

Up to the present time, various studies have been made chiefly by private propaganda-analysts and patriotic organizations; and broadcasters as well as private investigation groups will be asked to cooperate. The Commission plans to supervise radio broadcasts more carefully in order to tighten control. Thus, for instance, additional men are working on monitor, or listening stations which have been tracking down an increasing number of illegal stations. The Federal Communications Commission has already a number of *mobile radio listening posts* and their number will be greatly increased in the near future.

But, what is needed desperately right now is actual recordings of every United States station of every broadcast emitted. This in itself is an enormous undertaking, as can readily be imagined, but in view of what I have said above, it will be found necessary, without a doubt. While the danger of “radiobotage” is not so great from network programs—due to the fact that these usually are rehearsed and would, consequently, be stale by the time they are actually broadcast—it is the smaller broadcast stations which are dangerous at this moment. They are chiefly dangerous because subversive activity may go on, and no doubt has gone on already, without the knowledge of the owners of the stations. The quicker we close this, now wide-open door, the more effective our Defense efforts will become.

(*) See Page 637.

•THE RADIO MONTH IN REVIEW•

The "radio news" paper for busy radio men. An illustrated digest of the important happenings of the month in every branch of the radio field.



RADIO DETECTIVE!

Here's what the interior looks like of an F.C.C. "traveling radio detector" for tracking-down unlicensed radio sending stations. Hallicrafters receivers are used. This innocent-appearing car provides for recording the unlawful broadcasts, as well as determining their source by means of its direction-finding equipment.

effect in Great Britain against unlicensed radio transmitters. The war induced these governmental restrictions.

Berlin's shortwave propagandist Lord Haw-Haw, last month rebroadcast to America a recording of a portion of a transcription, broadcast a short time before over the N.B.C. net. The airing had featured Senator Nye during an N.B.C.-Chicago University Round Table Discussion program, the trade newspaper "Radio Daily" reported.

According to "PM," it was this newspaper's "rather impish" suggestion that Americans take Hitler at his word, when he recently broadcast a request that Americans send 25-word radiograms offering suggestions for improving the shortwave programs to the United States. Until the newspaper called attention to the potentialities of the offer, 10 days after it was first made only 1 radiogram for Berlin had been received, it was reported; but before the 10th day was out, 4 telephone operators had been added to RCA's staff to handle the resulting "witskrieg" (as another newspaper put it). Total number of "suggestions" was over 50,000, which cost Hitler about \$100,000, it was estimated.



ABROAD

A RMY officers and civilian observers recently returned from Britain report that development is progressing satisfactorily on airplane detectors which utilize photoelectric cells or "electric eyes." Designed to coordinate the aim of searchlight beams and anti-aircraft gun batteries, they represent a new hazard to night air-raiders, according to AP reports last month.

Secret agents of the Philippine constabulary and Manila police last month arrested one Japanese and held several others for questioning, in a sudden raid, for possessing an unlicensed radio transmitter and receiver.

A "target squadron" of 13 radio-controlled airplanes soon will be in use, in Honolulu, towing targets for U.S. anti-aircraft gun batteries, UP reported last month.

Radio-diathermy instruments come within the province of bans recently put into

F.M.

NOW that Frequency Modulation has received the blessings of the Federal Communications Commission, in the form of its OK to "go commercial," we look for meteoric progress in this field. Station No. 1 on the Honor Roll of commercial F.M. stations is W47NV, owned and operated by WSM of the National Life & Accident Insurance Co., Nashville, Tenn.

A number of commercial F.M. stations, by special permission, will continue to utilize their experimental transmitters for a time pending the arrival of higher-powered equipment that have been delayed by manufacturers' Defense orders.

Westinghouse Radio Stations, Inc., received construction permits for 4 F.M. transmitters, last month (no more than 6 are permitted under common ownership or control) . . . movie makers have moved into the F.M. field with the application by Metro-

AERO SIGNAL BLOCK

An "automatic block signal" system for airplanes in flight has been perfected by radio engineers of Transcontinental & Western Air, Inc. Miniature planes (arrow) proceed along a track at a rate proportionate to keep pace with a plane aloft. When the miniature plane arrives at check points the Dispatch Office radio man contacts the flight plane by radio and then "clears" it into the next block. The miniature plane rings an alarm, if it arrives at a check point before its airplane aloft.

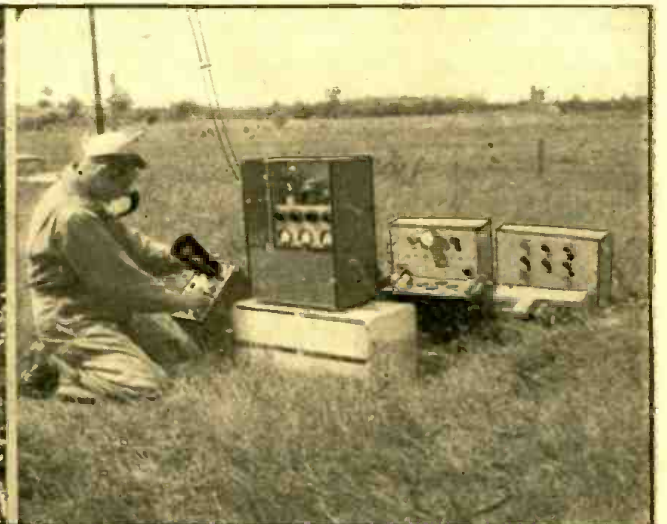

SCOUTING BY TELEVISION!

Television made its debut as a new and powerful defense weapon last month when 15 technicians of Allen B. DuMont Laboratories, in cooperation with U. S. Army personnel, demonstrated its military uses. The photo at left shows how the portable equipment was set up to view scenes of troop movements from ambush and transmit them over an ultra-shortwave channel to receivers at

Headquarters and a dozen other points! The television camera was connected by coaxial cable to a 25 watt transmitter in an army truck. The picture at right shows the mobile 25-watt relay television transmitter out in a field, several operating directly from the television camera and flashing a signal to the main transmitter miles away. The operator is monitoring the video signals.



SKI BROADCAST!

▲ Ski-record breaker Torgor D. Tokle is here shown in a preliminary jump prior to setting a new record last month, through a snow-storm, at Lake Placid, N. Y.—at the same time broadcasting over WGY and the N.B.C. net.

SUPERSONICS

The machine at right demonstrates chemical reactions under supersonic frequencies at up to 300,000 vibrations per second, reported "Science Observer" magazine. M.I.T.'s Dr. W. C. Schumb and E. S. Ritter use a vibrating nickel tube, A, which is actuated by driving and polarizing coils D and E, respectively.

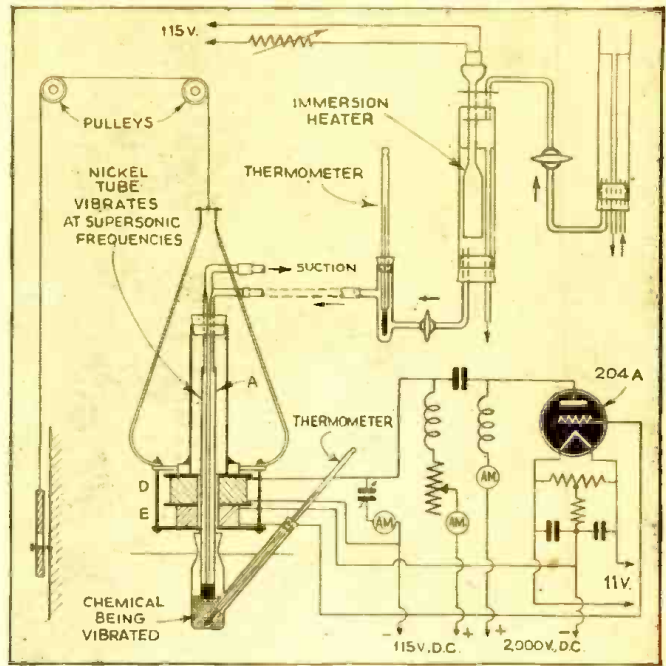

Goldwyn-Mayer for a construction permit. . . . The cost of F.M. transmitters at present lies between approximately \$5000 and \$100,000. . . . Zenith Radio Corp. has signed a 9-year lease with Chicago's 600-ft. Field Building, which is to house this set-maker's new 50 kw. station W51C. . . . The "New York Daily News" last month entered radio via its application for a permit to construct an F.M. station. . . . estimates place the total of F.M. receivers now in use in the Metropolitan (New York) area at about 8,000.

SOUND

A MICROPHONE made of frozen rubber is the subject of Patent No. 2,231,159, granted here to Erwin Gerlach of Berlin, Germany. Electrodes on either side of the thin insulating plate pick up the electrical voltages it generates, much like the soft-rubber, taut-diaphragm static-electricity microphone described in Radio-Craft, several years ago, in which a membrane of stretched rubber was shown to afford articulate speech when arranged as a microphone.

A unique feature of F.M. is the fact that all commercial stations in a given area are required, by regulations, to provide a signal of equal strength.

Here's how the Big Cities stack up in F.M. activity, by number of construction permits requested (R) and granted (G):

City	R	G	City	R	G
Philadelphia, Pa.	6	4	Los Angeles, Cal.	5	1
Schenectady, N. Y.	2	2	New York City	18	7
Providence, R. I.	2	0	Chicago	6	5
Hartford, Conn.	2	2	Detroit	4	2
Pittsburgh, Pa.	3	2	Boston	3	1
			St. Louis	3	0

"Uncle Don" wanted a vacation, so Uncle Don obtained his respite from the usual WOR stint for children by the simple expedient of leaving a week's-work of transcribed programs to carry-on in his absence.

At Rutgers University, New Brunswick, N. J., sound recordings are made of speech, as part of the technique in a new course designed to improve students' voices for dictating, telephoning, etc. An intercommunicator between 2 rooms enables class monitoring, from loudspeakers, of study conversations between students.

WHK-WCLE's program director last month received something new in the way of a fan "letter." A fellow with an idea, thought enough of his suggestion to make a sound-on-disc recording of it, and to send

the disc to director R. W. Richmond. The reverse side of the disc was blank for "reply."

A KDKA shortwave broadcast to England, of a program which featured 25 British refugee children, was recorded; it was then sent to Boston, and there again broadcast to England by shortwaves.

The actual sounds of aerial blitzkrieg, recorded in England during the worst air raids last Fall, were dubbed into an American radio drama, last month, in the "Hospital on the Thames" broadcast over the WOR-Mutual net. The sounds included the chattering of machine guns in an aerial dog fight over Dover, the din of "pom poms" during anti-aircraft fire, the frightening sound of "screecher" bombs, the sound of air raid sirens, the welcome "all clear" signal.

The demands of Uncle Sam's Defense program are beginning to pinch the toes of manufacturers of sound-on-disc blanks. No material to equal aluminum as a backing has as yet been found, manufacturers say. The present recording demand for aluminum totals about 500 tons annually.



"AIRING" THE CANARY

◀ In a recent broadcast over the N.B.C. Blue network, Dr. Orestes H. Caldwell (left) utilized the special birdcage arrangement shown here to transmit the heartbeat of a canary bird. The heart pulsations of the canary were picked up through its feet, by a perch especially built by Brush Laboratories to include a Rochelle-salt crystal pickup, and broadcast world-wide over N.B.C.'s 50 kw. international shortwave station WNBI.

WIRELESS "PA"

▶ A cable-free microphone* last month made its official debut as an important adjunct to public address work, when the Federal Communications Commission granted a construction permit to Guy S. Cornish for his Station W8XW1, shown at right, on 310 megacycles. It is proving an ideal solution to the problem of announcing winners at sporting events, etc., where use of a mike with attached cable would be impossible or unsafe.



*Also see "Wireless Public Address," Radio-Craft, Jan. '40.

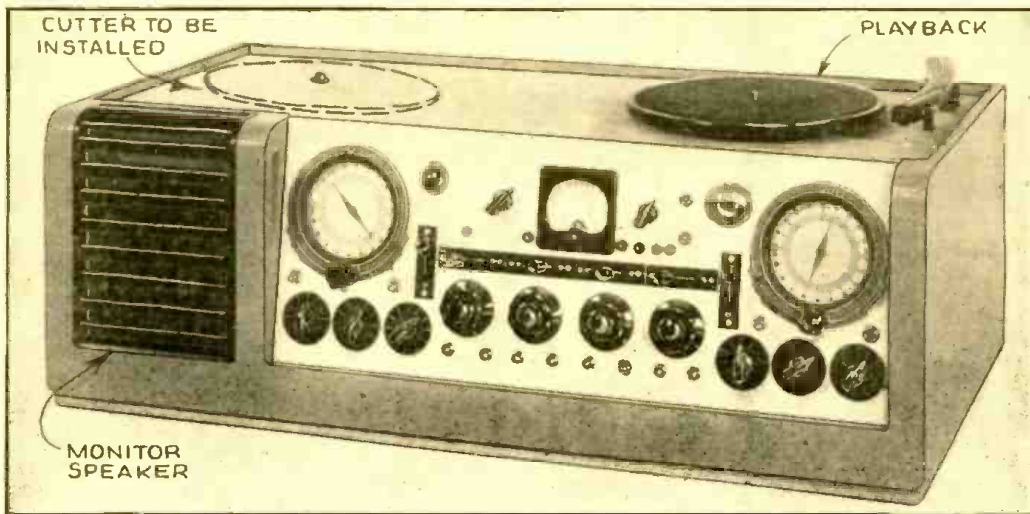

Front view of the P.A. - Radio - Recording Console as it looked in the process of construction (also note photo on cover). Only the playback turntable has been installed at this stage of the construction; and, the cover that encloses this equipment on top of the console has not yet been put in position.

How to Build a Modern 30/15-Watt **P.A. - RADIO - RECORDING CONSOLE**

Described here is a sound system incorporating the latest advances in circuits and equipment for high-fidelity Public Address, radio reception, and sound recording and playback. Complete construction details, including a specification list of components, will be given in this multi-part article so that anyone with a reasonable amount of technical ability may build it. This semi-portable P.A. - Radio - Recording Console incorporates exceptional versatility in a comparatively small amount of space.

R. J. BERGEMANN, JR.

PART I

FEATURES

- One 30-watt high-fidelity Program amplifier, 30-10,000 c.p.s., ± 1.5 db.
- One 15-watt high-fidelity Auxiliary amplifier, 30-10,000 c.p.s., ± 1.5 db.
- Independent electronic tone controls for each amplifier.
- Dual-speed recording and playback.
- Extra turntable for use in "dubbing."
- Built-in monitor speaker.
- Provisions for crystal headphones.
- Built-in T.R.F. tuner with A.V.C., diode detection and visual tuning "eye."
- Talkback key for studio work.
- Versatile switching system (permitting combinations of different portions of the amplifiers for unusual effects, added power, or measurement work).
- Db. meter also reads volts, ohms.
- Provisions for talkback system (with operation from remote points).

MANY Servicemen and sound technicians are beginning to notice the fruitful field of *semi-professional recording*. While it is often possible to add a basic recording mechanism to an existing amplifier, the results are never so gratifying as when the constructor starts from scratch. The instrument described here will satisfy the requirements of virtually all recording engagements regardless of location, and can be duplicated by a careful experimenter at a cost that is very low in comparison to the merit and versatility of the unit.

EQUIPMENT

The P.A. - Recording - Console, shown here and on the cover of this issue of *Radio-Craft*, comprises one 30-watt Program amplifier; one 15-watt Auxiliary amplifier, whose function will be described later; a dual-speed recording mechanism, and an adjustable-speed playback turntable, with lightweight pickups on both tables; a utility broadcast-band tuner with diode detection,

A.V.C., and a tuning "eye"; a volume indicator meter with calibrations for reading in db.; a self-contained 8-inch monitor speaker; crystal earphones, for monitoring when the recorder is used in the same room that serves the function of the studio, and the loudspeaker cannot be used without feedback; completely variable tone controls for both Program and Auxiliary amplifiers; and, a new "poly-directional" dynamic microphone, adjustable to meet all recording difficulties, yet compact enough to be carried in the compartment which is in the rear of the speaker.

Plans will also be included for constructing portable baffles for 12-in. speakers to be used in P.A. work. These baffles are especially designed for the P.M. dynamic loudspeakers which have been selected for this Sound System. Two of these speakers in the baffles mentioned above, will handle the full output of the Program amplifier for almost all P.A. jobs.

WHY 2 AMPLIFIERS?

There are many arguments in favor of including 2 amplifiers in the unit.

(1) Recordings can be made from one amplifier while the other is used to amplify the sound for an auditorium or hall. Since each amplifier has its individual tone controls, the response of the amplifier supplying the hall may be adjusted to reduce feedback, without changing the tone of the recording at the same time.

(2) The use of 2 amplifiers permits a simple talkback system for use when recording from remote locations or studios.

(3) Sound effects from a record source may be fed to the studio over the Auxiliary amplifier so that the performers being recorded may hear their cues.

(4) In the event of failure of one am-

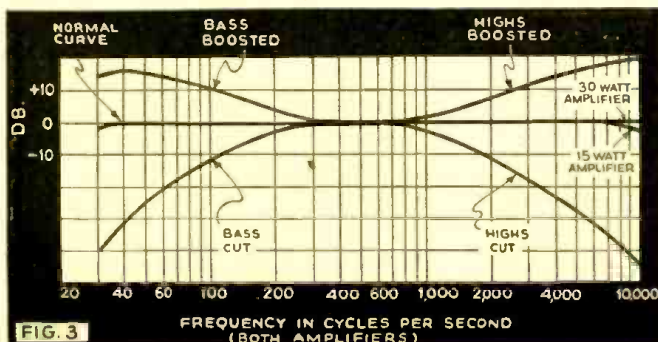

Frequency response curves were run using a frequency record in conjunction with a crystal pickup. The built-in meter was used to read the power level.

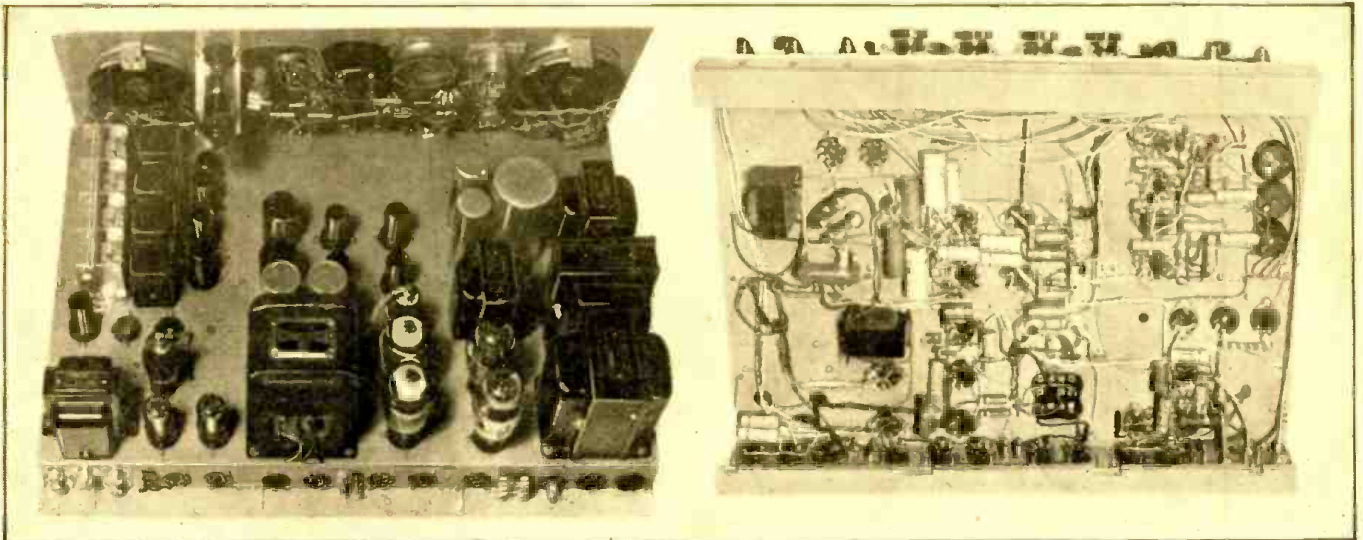

Top and (right) underside views of the chassis assembly of the P.A.-Radio-Recording Console. Drawings that make it easy to properly spot these components will appear in subsequent Parts of this article.

plifier, the other can be substituted by simple front-panel switching.

(5) With 2 amplifiers, it is possible to plot a frequency response curve on a loudspeaker or microphone. To run a curve on a mike, connect it to the Program amplifier and place it in front of the monitor speaker, the response curve of which is known. Feed the monitor speaker with the Auxiliary amplifier to which is connected the high-fidelity pickup. Play any commercial 30-10,000 c.p.s. frequency record, and record the meter readings from the Program amplifier. By subtracting the speaker's curve, the curve of the mike's response will be obtained.

COVER FEATURE

Degeneration in the cathode circuit is used to reduce the gain of the stage to unity (1). Due to the very large amount of feedback necessary to reduce the 6F8G with a gain of 14 to a stage gain of 1, the gain of the stage becomes almost independent of the tube gain, and largely dependent on the ratio of the plate and cathode resistors. A change in gain of 50% in the tube, would cause only a 5% change in the gain of the stage! Thus, the inverter tube maintains its original balance. The degeneration would also iron-out any distortion that might be present in the inverter stage.

Since there is degeneration in the phase inverter stage, the inverse feedback is placed only on the power stage. The feedback is accomplished through the 10% special feedback winding on the Thordarson output transformers.

BLOCK DIAGRAM

A block diagram of the entire unit is given in Fig. 1. A switching scheme allows the various channels to be connected to either amplifier. By connecting the amplifiers before the master gain controls, it is possible to use both tone control channels on the same amplifier. Thus, a mike may be tone-altered for unusual sound effects while another is used straight at the same time. A total of 8 channels is provided, 4 of which may be mixed. The lever switch above each channel gain control switches that control into either the Program or Auxiliary amplifier.

The talkback switch connections are shown in Fig. 2. In the upper position, the monitor speaker is connected to the Program amplifier. In the bottom position, the monitor speaker is connected to the Auxiliary amplifier. In the middle position, the monitor speaker is disconnected, and the studio speaker is connected to the Auxiliary amplifier. As shown in Fig. 2, the local mike remains connected to the Auxiliary amplifier, so to talk back to the studio; it is only necessary to throw the switch from upper to middle position, thus disconnecting the monitor speaker, and connecting the studio speaker to the Auxiliary amplifier.

The tone control circuit is conventional, using degeneration in the cathode circuit. Special hum-backing chokes and special tapered potentiometers are used. The bass boost is 15 db. at 50 c.p.s., the bass attenuation, 25 db. at 50 c.p.s. The "highs" control, boosts 10,000 c.p.s. 18 db., or cuts 10,000 c.p.s. 45 db. Frequency response curves are given in Fig. 3. The tone control circuit may be seen in Fig. 4.

The phase inverter circuit (Fig. 5) is quite different from that generally used.

MONITORING

Crystal phones are used for monitoring when a speaker would cause feedback. The response of the phones is comparable to that of the more expensive phones used in broadcast stations, and it is therefore possible to get excellent recordings even when a loudspeaker cannot be used for monitoring.

The meter used for monitor level reading is an inexpensive 0-1 ma. "foundation" meter connected as shown in Fig. 6 D.C. Both Volts and Ohms scales are included. If the builder incorporates these, he will need no other instruments to check and test the finished recorder. To accurately calibrate the meter for reading relative as well as actual db. is not very difficult.

Using the 10-volt A.C. scale and arbitrarily calling 1 volt "0 db.," every reading will be a multiple of the reference level. Now watts equal E^2/R , and for a constant resistance, watts varies directly as E^2 . Therefore, the reading of the meter, squared, will be the change from the reference level in terms of power. The log to the base 10 of the power increase, times 10, will be the increase in db.

For example: suppose that the meter reads full-scale. That will be 10 V., or 10 times the reference chosen. The power increase is therefore 100. Ten times \log_{10} of 100 is 20, and the gain is therefore 20 db. This is an arbitrary scale used for making frequency runs. Using the 100-volt range, across the 500-ohm line, add 15.2 db. to all readings if you want the db. above 0.006-watt reference level. Thus, full-scale deflection on the 100-volt range would be 20 db.

(the db. scale reading) plus 15.2 db., or 35.2 db. above 0.006-watt reference level. Incidentally, full-scale deflection on the 100-volt scale across 500 ohms, indicates 20 watts, and so this scale will probably be used most in P.A. work.

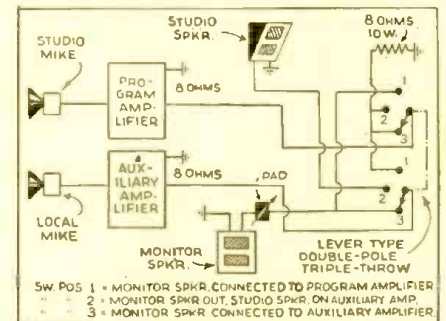

SW POS 1 - MONITOR SPKR. CONNECTED TO PROGRAM AMPLIFIER
2 - MONITOR SPKR. OUT, STUDIO SPKR. ON AUXILIARY AMP.
3 - MONITOR SPKR. CONNECTED TO AUXILIARY AMPLIFIER.

FIG. 2 - TALKBACK CIRCUIT

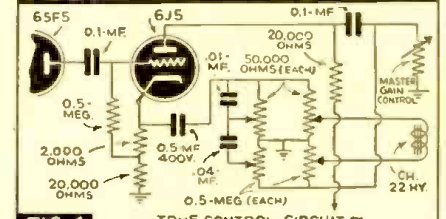

FIG. 4 - TONE-CONTROL CIRCUIT

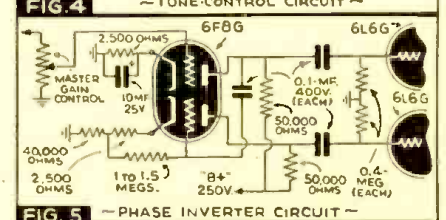

FIG. 5 - PHASE INVERTER CIRCUIT

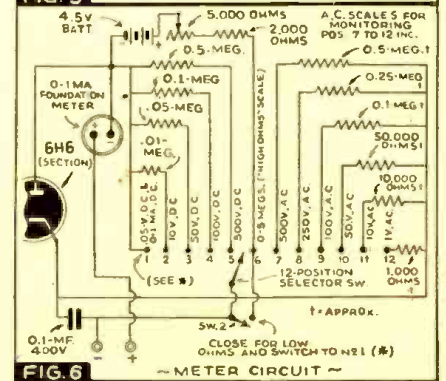
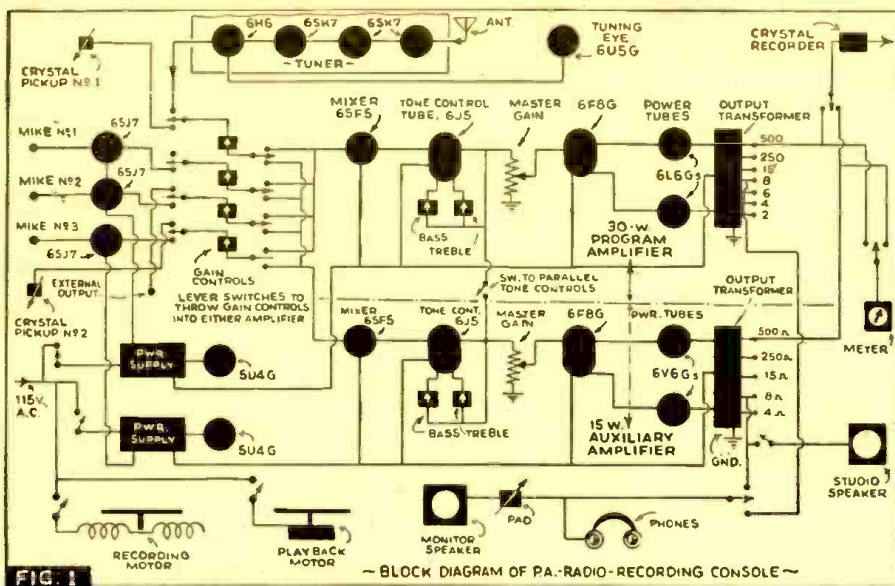

FIG. 6 - METER CIRCUIT



At the present time, both amplifiers are completed, and curves are shown in Fig. 3. Recordings have been made with excellent

response characteristics. We are waiting for a new dual-speed mechanism to arrive before completing the cabinet. In a forth-

coming issue of *Radio-Craft*, complete construction details and instructions on recording will be given.

GENERAL COMMENTS

The advantage of the electronic tone control lies in the fact that either end of the audio spectrum may be accentuated instead of merely being attenuated, as the majority of tone control circuits do. With the use of this control it is possible to emphasize bass and/or brass in recording and reproducing.

"Dubbing," or the adding of material to an existing record, is accomplished by placing the existing record on the play-back turntable and copying to the recording turntable while blending the microphone with the pickup. Since both turntables are dual speed (one is adjustable), it is possible to test at the slow speed, thus saving on record cost. It is also possible to copy and dub from one speed to the other.

The T.R.F. receiver incorporated in the unit was expressly designed for "off the air" recordings. Although used primarily for local stations, the R.F. gain is sufficient to receive most of the smaller stations. Automatic volume control was included to prevent fading during recording. The tuning eye insures accurate tuning.

CASE HISTORIES OF P.A. SALES

No. 13—Hi-Fi Sound For Old Sets

OPERATE a small radio service shop, and recently have started public address work.

On August 7th, one of my customers dropped in to say "Hello" and the subject of high-fidelity sets came up. He seemed interested in the possibilities of improving his old set, and building an amplifier for his record player, which I told him I could do. I quoted him a price of \$50 for the complete job which he OK-ed.

I next purchased a 10-watt amplifier kit from a local manufacturer, Phelps-Dodge. The amplifier employed the following tubes: 6J7, 6C5, 6A5s in push-pull, and an 83 rectifier. The amplifier had a resistance-capacity coupled 1st stage which fed into a transformer-coupled push-pull output stage. The amplifier had a gain of 85 db. and a frequency range of 40 to 15,000 cycles within 2 db. It also had a volume control in the input circuit of the 6J7 (which is self-biased with Mallory cells), and a tone control in the plate circuit of this same tube.

I was busy thumbing catalogs to find a suitable speaker when my customer phoned to tell me that he had decided on the new Jensen speaker, Hi Fidelity model PM-15, which the day before we had discussed using. I used a special matching transformer, for the output of the amplifier. The speaker, a 15-in. permanent-magnet type, I mounted on a 5 x 6 ft. baffle made of 3/4-in. Celotex.

As the original amplifier called for a dynamic-type speaker I had to substitute a filter choke in place of the field. The purpose of the installation was to provide a means of obtaining finer quality from an old AK-60 radio set; and also, to afford a means of operating a record player and of using a crystal microphone.

In order to save time in making connections for these 3 services I wired the input circuit to 3 closed, single-circuit jacks and a 3-point single-deck rotary switch. The arm was wired to the input of the amplifier, and one side of the jacks to each of the taps on the switch. The other side of the input and the jacks went to ground.

To remodel the receiver I disconnected the lead from the plate of the detector tube and connected a single shielded wire which plugged into the proper jack.

This amplifier was chosen because it was reasonably priced and had sufficient gain. I could then allow more money for a good speaker. As it turned out, he went over the original price, when he requested the Jensen speaker.

Now came the moment I waited for the first test. The radio set played fine through the amplifier, but when I switched-in the record player there was a decided hum. I suspected the player, so I remounted the motor on a suitable piece of Masonite which gave a nice appearance to the player and, with the placing of a 0.1-mf. tubular condenser of 400 w.v. from ground to one side of the line feeding the player 110 V. A.C. line this eliminated the trouble. Microphone gave no problems and worked fine.

The complete installation cost as follows:

- Phelps-Dodge type HF-11 foundation amplifier kit.....\$17.60
- Tubes, condensers, resistors, jacks, plugs, Yaxley rotary switch, etc... 23.00
- Baffle board 10.00
- Jensen type PM-15 speaker 42.00
- Thordarson type 58F72 output transformer 4.00
- Inca D-25 filter choke 3.00
- Universal crystal mike type 15-MM, stand, cable, plugs 32.00

Total\$131.60
plus \$5 for labor.

\$131.60 list price
78.96 net

\$52.64 profit

Well that's the business, not bad for 3 days' work. Sure wish I'd entered public address work sooner.

FREDERIC URLAN DILLION,
Hollywood, Calif.

Mr. Dillion's prize was 5th in the 4th Section of the \$4,000 P.A. contest "R.-C." sponsored at the beginning of last year.

WHEN RADIO WAS A BABY

Being the Recollections of the Old Days of Broadcasting

Broadcasting was a rough and tumble business around the small radio stations a decade or so ago, with the spirit of the fun-loving Rover boys riding high, recalls WOR announcer George Hogan. George remembers the days back in the late 20's when he worked at a small Midwest station, before broadcasting became a big business. . . .

. . . When trying to break up an announcer while he was on the air was the favorite indoor sport, i.e., shooting a water pistol into an announcer's mouth while he was talking, turning on the electric fan and scattering his script . . . pouring water on his head . . . undressing an announcer before the mike.

. . . When programs used to run eighteen or twenty-five or thirty-three minutes.

. . . When small town sponsors were so thrilled at the idea of being radio sponsors that they came up to the studios every night to watch their broadcasts and took the whole cast out to dinner afterwards.

. . . When every little one-lung station was a training ground for talent and developed everything from hillbillies to classical organists.

. . . When listeners called the station to ask what color eyes a singer had, or phoned-in to request a number.

. . . When listeners called up to say they enjoyed the show, and to tell whosis that he "sang especially well today."

. . . When every movie and stage actor, big or small-time, who passed through town was brought up to the mike to say "Hello, I'm so thrilled to be here with you."

SUPER-CYCLOTRON

The University of California last month announced it had received a grant of \$1,150,000 from the Rockefeller Foundation which, with an additional needed \$250,000, will make it possible to build a 100,000,000-volt "super-cyclotron" for the investigation of atomic physics. The completed machine's ion beam will melt a building brick like a blow-torch melts a pound of butter.

"THE Easiest SHAFTS IN THE WORLD TO INSTALL!"

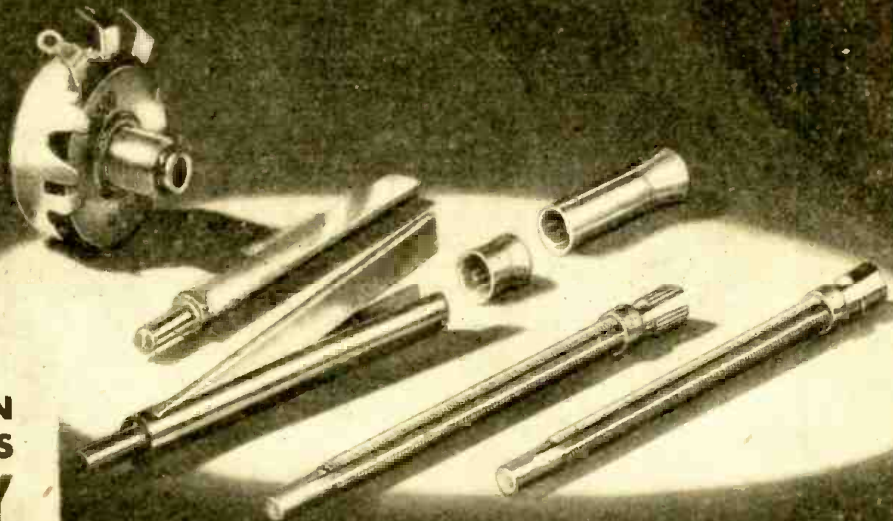

**TAP-IN
SHAFTS
STAY
PUT..**

and here's why!

IRC Tap-in Shafts won't slip or vibrate loose. The shaft socket is carefully gaged to a standard Brown & Sharp taper and the shaft taper is accurately machined to such a smooth, close fit that the surfaces are practically bonded together when engaged by a few taps of a hammer. This taper-socket principle is standard practice in machine tool work—from screw machines to giant lathes—where cutting tools for high speed or rugged work must be held securely in place.

NEW DOUBLE-FLATTED TYPE "A" SHAFT ELIMINATES INSERTS and FILING



This isn't our verdict . . . it's the verdict of thousands of servicemen who have found the Tap-in Shafts of IRC Type D Controls the answer to countless problems. They save your time—they save you money. Tap-in shafts make it possible to handle the big majority of all replacements with only a small stock of controls. They frequently enable you to use a standard Type D Control instead of a more costly, hard-to-get "special." Flats are easily located in any desired position. Shafts can be inserted after the control has been installed. It's unnecessary to remove other parts when making an IRC replacement in a crowded chassis. Once inserted, and tapped solidly in with a hammer, the shaft is there to stay. You don't have to fiddle with lock washers to hold it in place.

Don't fail to examine Type D Controls the next time you visit your distributor . . . and be sure to ask him about the IRC Master Radiotrician's Control Cabinet with its stock of only 18 Type D Controls, 6 switches and 5 special Tap-in Shafts that handle from 60% to 75% of all replacements!

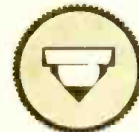

Shaft position in knob requiring 3/32" flat.



Shaft position in knob requiring 1/32" flat.



How shaft is positioned for set-screw knob.



Only edges of shaft are filed for odd types.

Here's the answer to simplified fitting for all knobs. No more bothersome metal inserts necessary . . . shaft filing eliminated for all 1/2" or 3/8" standard flats . . . easier-to-cut to length, too.

IRC TYPE D UNIVERSAL VOLUME CONTROLS

INTERNATIONAL RESISTANCE CO., 401 N. BROAD ST., PHILA., PA.

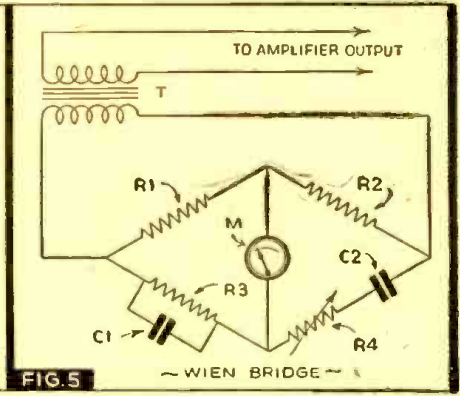
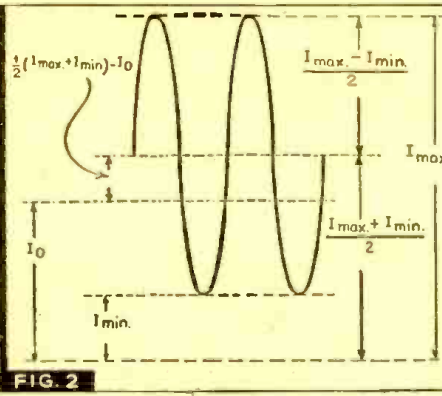
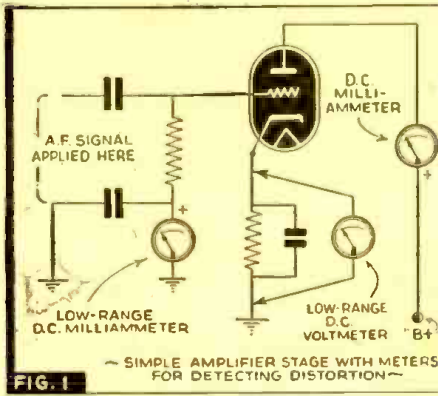

MEASURING DISTORTION IN AUDIO-FREQUENCY AMPLIFIERS

In the following article (reproduced from "The Aerovox Research Worker" by courtesy of the publishers) the elements of qualitative analyses of A.F.-amplifier frequency distortion, as commonly applied by sound technicians, are mentioned. The more precise methods of making quantitative analyses are then described at length.

THE simplest qualitative test for distortion in a class A audio-frequency amplifier stage may be made, as shown in Fig. 1, by applying a signal voltage of proper level to the input and inspecting the circuit for one or all of the following abnormal conditions:

- (a) Presence of D.C. grid current.
- (b) Fluctuation of the D.C. plate current.
- (c) Fluctuation of the D.C. cathode voltage, if the circuit employs cathode resistor bias.

Each of these indications generally occurs in a positive direction, and each will disappear upon removal of the signal. It must be borne in mind, however, that this method is purely rudimentary in nature and serves only to detect the presence of distortion. One or two of the indications may be absent, depending upon the main cause of the trouble.

QUALITATIVE TESTS FOR DISTORTION

The 3 simple indications are well known and frequently used by Servicemen and P.A. testers who have no equipment suitable for making quantitative distortion measurements, but must, in the course of routine testing, localize distortion without reference to the actual per cent harmonic energy present.

The cathode circuit effects noted above are due to fluctuations in the voltage drop across the cathode resistor, occasioned by variations in the D.C. component of plate current. The current indicated by the plate-circuit milliammeter is the average value of the fluctuating "signal" plate current, is identical with the D.C. component, and is the current that produces the cathode resistor drop.

These facts may be better comprehended when it is remembered that the fluctuating signal plate current (Fig. 2) is an alternating current, corresponding to the signal, superimposed upon a direct current. It will

be evident from the fundamental relations of this combination that the average value of plate current, as indicated by the plate-circuit milliammeter, will be constant in the company of the alternating component under distortionless operating conditions.

Figure 2 is a graphical representation of signal plate current. Here, I_{max} is the maximum value reached by the fluctuating plate current; I_0 the zero-signal value; I_{min} the minimum value. From these values, it may be shown that the per cent 2nd-harmonic content (often the most troublesome distortion factor) is equal to:

$$\frac{\frac{1}{2}(I_{max.} + I_{min.}) - I_0}{I_{max.} - I_{min.}} \times 100$$

Quantitative methods of checking distortion are harmonic analyses, and are concerned with measurement of the actual amount of energy present in each separate harmonic of the signal frequency (or in the total harmonic content) and establishment of percentages with respect to the fundamental frequency. The most representative methods employed in wave analysis and the apparatus necessary thereto will be described presently.

OSCILLOSCOPIC METHOD

The cathode-ray oscilloscope is notably useful in the observation of wave shapes. When the horizontal plates of the ray tube are energized by a sawtooth-wave sweep-oscillator-amplifier circuit to furnish the linear time base, and a signal voltage which it is desired to observe is applied to the vertical plates through a substantially flat-response amplifier, the cathode-ray trace will be an exact reproduction of the waveform of the applied signal voltage.

An audio-frequency amplifier may be checked for distortion with the oscilloscope in the manner illustrated in Fig. 3. At A is an audio oscillator possessing an output voltage waveform of known purity, B is the amplifier under test, and C is an oscillo-

scope having horizontal and vertical amplifiers with substantially flat frequency responses. The units are connected in the order shown.

It is the purpose of the oscillator to supply a signal of as pure waveform as practicable to the amplifier, and that of the oscilloscope to reproduce the wave-shape of the signal after it has passed through the amplifier. In order that as little distortion as possible be introduced by the instruments themselves, the oscillator used for such a test must be of exceptionally high quality and the amplifiers in the oscilloscope must possess an excellent frequency characteristic. Likewise, the oscilloscope sweep circuit must be uncompromisingly linear in its characteristic.

If the amplifier had no distortion at all, the signal it delivered to the oscilloscope would be an exact reproduction of the input signal waveform. This is never encountered in practice, however, the most efficient amplifier arrangement being beset with the distortion characteristics of its tubes and other components.

For observations, a perfect sine wave (or, better still, a tracing of a single cycle from the test oscillator) might be inscribed on the transparent viewing screen of the oscilloscope, and signals from the amplifier matched to this pattern to discover variations from the original shape due to amplifier distortion. In making such a test, it would of course be necessary to adjust both oscilloscope amplifier gain controls in such manner that the maximum amplitude and width of the signal trace coincided with those dimensions of the inscribed pattern.

With the low percentages encountered with most well-designed amplifying equipment, it will be difficult to estimate the percentage of harmonic content from the reproduced wave-shape, in the oscilloscopic method, unless the operator makes use of the transparent screens furnished by some oscilloscope manufacturers for the purpose. These screens carry printed patterns of single cycles corresponding to the shapes

obtained (variations from true sinusoidal) with various low percentages of distortion. Severe cases would result in images similar to Fig. 4 which is an exaggerated representation of pronounced 3rd-harmonic content.

FREQUENCY BRIDGES

Certain bridge circuits, notably the Wien bridge (see Fig. 5) can be used for the identification of frequencies in the audio-frequency spectrum. If an alternating voltage is delivered to the bridge circuit, the latter may be adjusted for a null at that particular signal frequency. The null point would not hold for the same voltage of another frequency. Thus, the adjustable element of the bridge might be calibrated to read directly in cycles/second.

The Wien bridge in its most useful form for this purpose would have its constants so chosen that the ratio arm, R_2 is twice the ohms value of R_1 , the condensers C_1 and C_2 are equal in capacity, and the 2 simultaneously-adjustable resistance legs, R_3 and R_4 , are at all positions equal. Under these conditions, the frequency of the impressed voltage at null would be equal to:

$$f = \frac{1}{2\pi RC}$$

Where:

- Frequency is in cycles/second,
- R is the resistance of R_1 or R_2 in ohms,
- C is the capacity of C_1 or C_2 in farads.

Since the bridge may be balanced for only one frequency at a time, it would appear that any residual voltage indicated by the vacuum-tube voltmeter, M, at null would be due to some other frequency or frequencies (such as harmonics of the fundamental). And this harmonic voltage would be due to the total of harmonic voltages present. As such, the bridge might be connected, as shown in Fig. 6, to the output circuit of an audio-frequency amplifier which is passing a signal from a high-quality audio oscillator.

While the device might be used as shown as such a harmonic totalizer, the percentage total harmonic content with respect to the readings of the meter before and after null would not be reliable, nor would its error be uniform for all frequencies. These facts are due to the peculiar nature of the bridge to attenuate various harmonics unequally.

Another popular type of bridge harmonic totalizer (due to *U.T.C.) is shown in Fig. 6. Here, 3 legs of the bridge. R_2 , R_3 , and R_4 , contain pure resistance, while the 4th leg contains the shielded parallel resonant circuit, L-C, which is resonant at the test frequency. The transformer, T, like the one shown in the bridge previously described, must have an excellent frequency characteristic.

At resonant frequency of L-C, the inductive reactance of the tuned circuit equals the capacitive reactance, the former is canceled by the latter, and the bridge balances as if all 4 legs were pure resistance. Any voltage applied by the circuit to the vacuum-tube voltmeter is then due to harmonics of the test frequency (and it is assumed that these harmonics have been delivered to the bridge by the amplifier under measurement).

In operation, the double-pole, double-throw switch, S, is thrown to position 2 and the bridge balanced with the assistance of the vacuum-tube voltmeter, M, as a null indicator. The reading at null (due to harmonics) is recorded. The switch is then thrown to position 1 and R_2 is adjusted until the meter gives the same reading (as before at null). The following calculation may be performed to determine the per-

*United Transformer Corp.

15 WATT AMPLIFIER at \$10.75 GIVES 3100 HOURS Continuous SERVICE —AND STILL GOING STRONG!



Read This Amazing Letter

MUELLER-O'NEIL COMPANY
Amplifier Engineers
5740 Barrow Avenue
St. Louis, Mo.

CHECK THESE FEATURES

- EXTRA HEAVY CHASSIS
- COMPLETELY SHIELDED
- ALL OVERSIZED COMPONENTS
- SIX TUBE CLASS A PUSH-PULL
- FIFTEEN WATT OUTPUT
- THREE INPUT POSITIONS
2 Microphone, 1 Phono Input
- 2-4-8-500 OHM OUTPUTS
- HIGH GAIN, WIDE FREQUENCY RESPONSE
- CONTINUOUS, VARIABLE TONE CONTROL
- FOUR STAGES OF AMPLIFICATION
- TUBE LINEUP 1-6SJ7, 2-5C7, 2-6N6, 1-83V
- OPERATION ON 110-120 Volts, 50-60 CYCLE
- LIST PRICE \$24.50—YOUR COST ONLY \$10.75 (less tubes)

BUY THE BEST FOR LESS!

Don't let our low price fool you! When you buy a TokFone Amplifier you're buying QUALITY. Mr. O'Neil's letter and many others like it prove that you need not pay high prices to get High Quality.

10.75
FOR AMPLIFIER
Less Tubes F.O.B., N.Y.
(Kit of Matched Tubes add \$4.50)

A COMPLETE ALL-PURPOSE SOUND SYSTEM FOR ONLY \$32.50

The amplifier described above may be purchased alone or as part of the Complete TokFone Sound System. Here's what you get:

15 Watt Amplifier as Described	LIST PRICE \$24.50
2 12" Speakers @ \$7.50 each	15.00
2 Wooden Speaker Baffles @ \$10.00 each	20.00
1 Crystal Microphone with Desk Stand	12.50
1 Kit of 6 Matched Tubes	9.30

TOTAL \$81.30
For amplifier screen cover add \$2.25

MAIL COUPON TODAY!

Regal Amplifier Mfg. Co.
16 West 17th St.
New York City

Gentlemen, We have five of your 15 watt amplifier systems working 24 hours a day here at the Union Station in St. Louis for giving instructions to our trainmen. Two of these systems have been in use continuously since July 22nd 1940. The sets have never been turned off. We even had to change up more than 15 seconds.

There are 16 horns connected to this system spread over 5 city blocks and 2 inside speakers located in make-shift shelters along the tracks. The noise level is terrible when trains are passing and to overcome this requires a lot of volume. A football game is a wodge compared to this noise we have to work through.

To cut off the amplifier when not in use I use a toggle switch shored across the output. The best this is cut in and out.

This installation required dependable equipment and your TokFone amplifiers came thru in great shape.

Yours very truly,
Donald McNeil
Mueller-O'Neil Co.
Western Electric Equipment Dept. Exclusively

Regal Amplifier Mfg. Co.
16 West 17th St.
New York City

- Send me 15 watt amplifiers at \$10.75 (less tubes)
- Send me 15 watt sound systems @ \$32.50 (less tubes)
- Send me kits of matched tubes @ \$1.50
- Send me screen covers @ \$2.25
- Send me complete illustrated catalog and price list.

Name

Address

City State

cent of total harmonics from this operation:

$$\% H = \frac{R_2}{R_1 + R_2} \times 100$$

or:

A dial indicator attached to the potentiometer R_2 may be calibrated directly in these percentages.

FILTER-METER

A very efficient method of measuring total harmonic content in the signal delivered by an audio-frequency amplifier makes use of the arrangement employed in the distortion and noise meters found in broadcast stations. (See Fig. 7.)

In this arrangement, the signal from a high-quality sine-wave audio test oscillator is fed into the amplifier under test. The

amplifier output is connected to a high-pass filter which removes the test frequency but leaves all of its harmonics.

The actual voltage due to the harmonics is then measured by means of an attenuator and vacuum-tube output voltmeter. This measurement is one of total harmonic distortion, but it is entirely possible to arrange additional flat-response amplification with various high-pass filters to remove the various harmonics singly along with the fundamental.

WAVE ANALYZER

The wave analyzer, a highly-developed and refined form of heterodyne vacuum-tube voltmeter, provides the most advanced, accurate, and complete means of measuring amplifier distortion by determin-

PROOF
of your money's worth
when you get RCP
TEST EQUIPMENT

RCP
MULTITESTER
AC-DC
Model 446
\$95

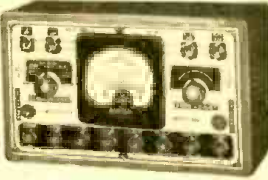

Five range DC voltmeter 0/5/50/250/500/2500
Four range DC milliammeter 0/1/10/100/1000
DC Ammeter 0/10
Four range AC voltmeter 0/10/100/500/1000
Three range ohmmeter 0/500/100,000/1 Meg.
Four decibel ranges—8 to 15/12 to 35/26 to 49/32 to 55
Output meter—same as AC voltmeter

Actually, it's the equivalent of 25 different instruments in a single case! Professional appearance, quality and performance put Model 446 in a class with testers selling for twice its cost.

You'll find BIG VALUE—LOW PRICE a feature of all RCP Test Equipment.

RCP'S COMPLETE LINE is described in Catalog No. 124. Send a postcard for your free copy today.



RADIO CITY
PRODUCTS CO., INC.
88 PARK PLACE • NEW YORK, N.Y.

BASIC
RECORDER
AND PLAYBACK



Made by nationally known manufacturer. Has Astatic L-26-W crystal playback pickup. Shure 9614D cutting head. 4.2 ohms impedance at 400 cycles. Cuts up to 10". Plays 12" records. Mounted on steel plate 15" long and 10" wide. 115 volts 60 cycles.

\$1495 F.O.B.

AUTOMATIC RECORD CHANGER \$12.95
115 volts 60 cycles

UNCUT
COMBINATION AND CONSOLE
CABINETS

WRITE FOR LATEST FOLDER

LAKE RADIO SALES CO.
618 W. RANDOLPH ST., CHICAGO, ILL.

Be a RADIO SERVICE EXPERT
LEARN AT HOME IN SPARE TIME

The demand for radio experts grows every day. Learn this paying profession under personal guidance of qualified engineer and educator. Clear, fascinating instruction and experimental kits make learning easy. Leaders in the radio industry endorse R.T.A. methods. Spare time. Profits soon. Pay for training.

NOW IS A FINE TIME TO START

New National defense program requires radio trained men in radio factories and every branch of U. S. Service. Opportunities for advancement almost limitless.

FREE Write today for complete information and radio book telling what R.T.A. training can do for you.

RADIO TRAINING ASS'N. OF AMERICA
3559 Devon Ave. Dept. RC-51 Chicago, Ill.

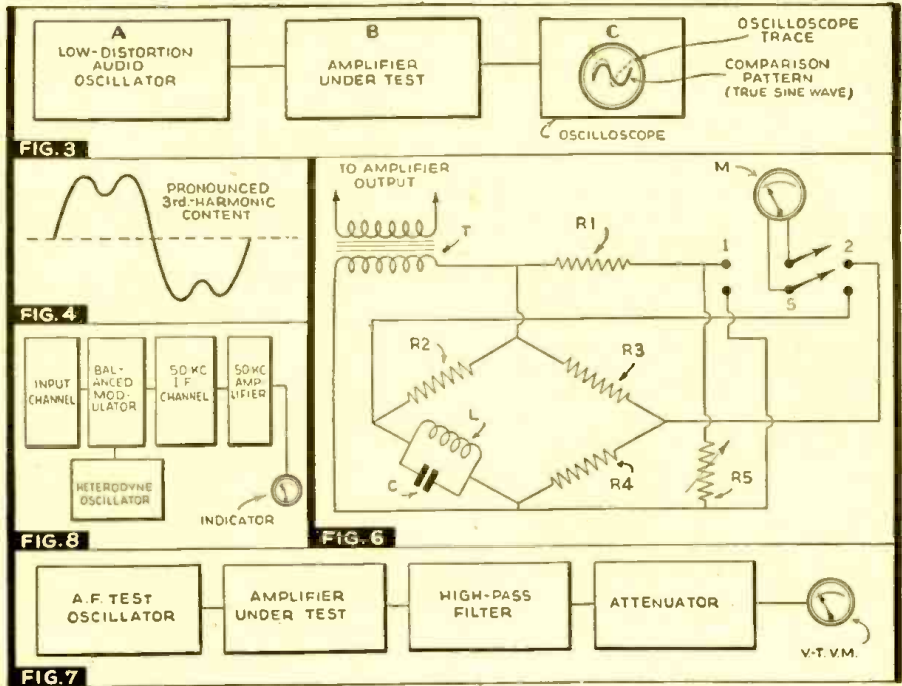

ing the various harmonic voltage magnitudes. The instrument is tunable to the fundamental and any of a series of its harmonics separately, so that waveforms of considerable complexity may be investigated. At the same time, measurements of hum and noise amplitude are made available. In effect it is a highly selective electronic voltmeter.

The representative wave analyzer (General Radio) receives the signal to be inspected through an input channel embracing an input multiplier, amplifier, and pad (see the functional block diagram of Fig. 8). The frequencies accepted by the input channel lie in the range 20 to 16,000 cycles/second—the entire common audio-frequency spectrum. A local heterodyne oscillator stage supplies heterodyning voltage of such frequency variation that throughout the signal input range, an intermediate fre-

quency of 50 kc. may be produced. The dial controlling this oscillator is graduated in the frequencies admitted by the input channel.

The fixed-frequency 50 kc. I.F. channel is extremely sharp, containing 3 quartz crystals and is preceded by a balanced modulator, the output of which contains the upper and lower sidebands obtained from the heterodyning process. The carrier is suppressed. The superselective I.F. channel is followed by a 50 kc. amplifier and the indicating instrument.

In operation, the wave analyzer is tuned to the fundamental test frequency and then to the successive harmonics to an extent determined by the amount of frequency tuning range between the fundamental and the 16-kc. limit of the dial. The harmonic amplitudes are indicated directly by the meter.

BROADCASTING

Now that station WLW has been booted out of first place among high-power stations of the world, by being denied the right to put 500 kw. on the air, Mexican station XEW probably will move in with an antenna power rating of 250 kw., according to *Broadcasting* magazine reports. This Mexico City station will lay down a very strong signal over a wide territory on 900 kc. (after shifting from 890 kc.). The question of super-power apparently will not take "no" for an answer, what with F.C. Commissioner Fly admitting that power increases have been considered from the standpoint of affording better national coverage as aid in the defense program. In this connection it is interesting to note that N.B.C. figures that the beam operation of 50,000-watt international broadcast stations WNBI and WRCA, both in Bound Brook, N. J., makes them equivalent to 500-kw. non-directional broadcasters.

A suburbanite solved the problem of how to get the numerous birds in his local woods to sing, mornings. Turning on, full blast, a portable radio set tuned to WOR's Sunday morning airing of the "Singing Canaries" did the trick.

Mr. Winchell, could you spare one of your orchids for Dave Elman's priceless "Contact" program? He really does bring together business people, friends and families that have made great efforts and even spent fortunes in unsuccessful attempts at coalition.

Radio broadcasting sometimes takes time out to play the part of a Good Samaritan. Last month, for example, KDKA learned the latest word on a situation which had developed from a broadcast of several months previously. It all started when Mrs. Jean Bichier, a French refugee living in Rock Ridge Baths, Virginia, wrote to Mr. Ralph W. Harbison, president of the National Council of Y.M.C.A. whose program had included a detailed description of life among prisoners of war in Germany. Mrs. Bichier asked Mr. Harbison whether he could find out anything as to the whereabouts of her husband, her inquiries in other directions having been fruitless. Well, what with the combined help of the Y.M.C.A., and the International Red Cross, Mrs. Bichier's husband has been located in a German military camp, and letters are now being exchanged.



AND Now

ABATTERYMERCHANDISER

Sells More Batteries

Lets Your Customer See Battery's Condition



- Set Switch for Voltage
- Read condition of Battery on percentage of useful life meter
- Made by TRIUMPH
- For Counter use or Can Be Mounted on Wall

win trade from drug stores and filling stations

MAKE MORE MONEY with N.U. BATTERIES

sold exclusively to Radio Service Dealers

The N.U. line of radio replacement batteries has been developed exclusively for radio service specialists. All popular types are included. Batteries are attractively packaged in rugged boxes incorporating the standard N.U. color scheme—black and two shades of green.

N.U. Batteries are carefully manufactured from the finest materials obtainable and are fully guaranteed against defects in workmanship and materials. All types equipped with standard plugs for quick and easy replacement installation.

Thoroughly moisture proof for satisfactory and reliable service under all climatic conditions.

Install N.U. replacement batteries for more hours of reliable service and satisfied customers.

© 1941 N.U.R.

Only \$8.00 Deposit

Delivery made at once on \$8.00 deposit and order for \$10.00 worth of batteries, dealer prices. Deposit refunded on purchase of 430 points. All purchases of N.U. tubes, condensers and batteries count as points.

N.U. brings you a line of replacement batteries on which you can make your full radio service profit. It is not necessary now for you to test sets and install batteries without adequate compensation for your time and knowledge.

N.U. has been identified with the radio service dealer and his problems since the beginning. You can definitely make more money handling N.U. products.

See Your Distributor or Send Coupon

NATIONAL UNION RADIO CORPORATION
57 State Street, Newark, N. J. RC 51

I am interested in your new Battery Merchandiser calling for only \$8.00 deposit. Please send more information.

Please have salesman call.

Name

Street Address

City..... State.....

NATIONAL UNION RADIO CORPORATION
57-STATE STREET, NEWARK, N. J.

Corporation

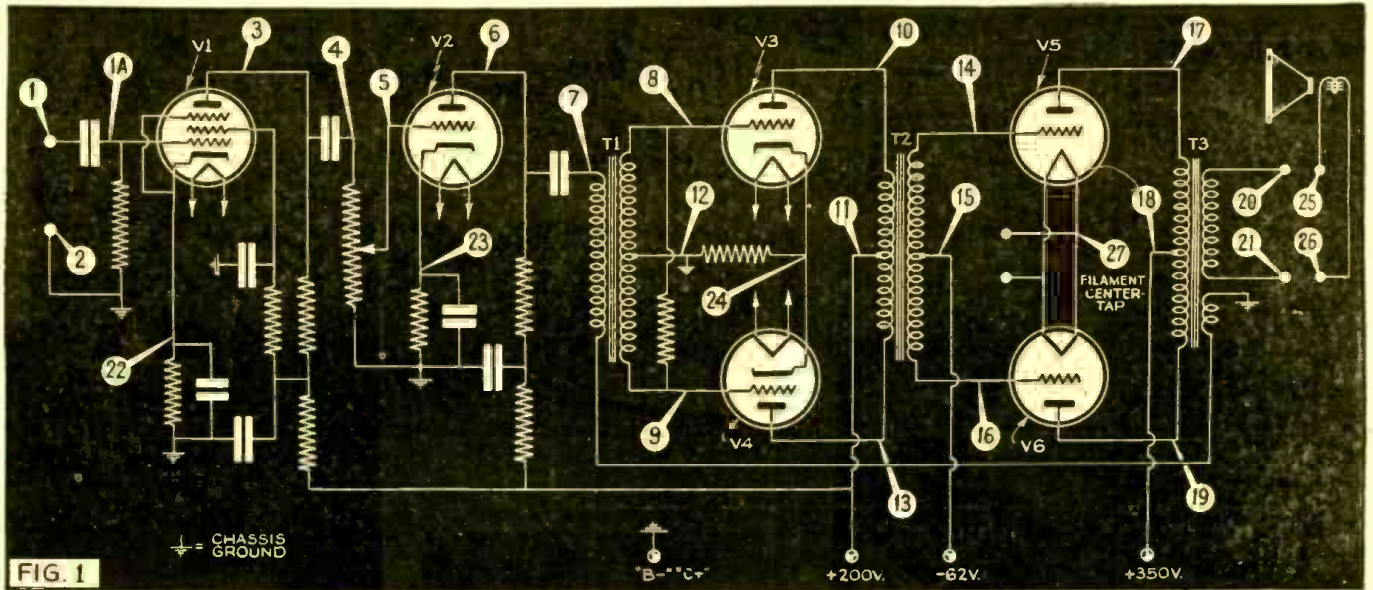

HOW TO MAKE DYNAMIC TESTS ON AUDIO AMPLIFIERS

This article answers all the elementary questions of how to make gain (amplification) measurements, derive frequency-response curves, and check for distortion and its location, and quickly detect resonant points (due to loud-speakers, loose components, or housings) in audio-frequency amplifiers.

TED LADD

THE principle of "Dynamic Servicing" is as important to *sound amplifier* practice as it is to *receiver* testing. Only a true dynamic test will indicate functional disorders in an audio system. When an amplifier is checked under actual operating conditions, the quantitative data obtained give a true picture of performance and bares defects in design and components that no other type of inspection could reveal as quickly and definitely.

A full dynamic amplifier test, such as will be described in this article, is in every respect identical with the system of engineering measurements performed by the audio design engineers and production checkers who create amplifying equipment. A complete inspection of any power amplifier, whether operating normally or below par, will embrace each of the painstaking measurements ordinarily made only in the factory laboratories. The P.A. Serviceman who learns and applies the methods of dynamic audio testing will be able to offer bona fide engineering service and will profit accordingly. Various amplifier ills that baffle his colleagues will no longer present a mystery to him.

The man who masters dynamic testing will be able to offer a routine inspection service to owners of every type of amplifying equipment, a profitable service which is invaluable in that it detects the breaking down of tubes and circuit components sometime ahead of actual failure. At the same time, he will be equipped to inspect new audio equipment for prospective customers, appraising the worth of competitive units. His advice will be invaluable because it will be based upon engineering measurements.

NATURE OF THE TESTS

Dynamic audio testing is easily understood. It is based upon the simple principle of supplying an audio-frequency voltage of known level and frequency to an amplifier, or any portion of an amplifier and following the progress of that voltage through the entire system to the output speaker circuit.

A voltage indicator with exceptionally good frequency response is employed in tracing the signal through the various circuits and circuit branches, and the system closely resembles the familiar *signal-tracing channel analysis* which is the foundation of dynamic receiver servicing.

Each channel of the amplifier system is carefully checked to determine if the signal is undergoing the proper amplification and if it is being transferred efficiently from one stage to another. Whether the signal is present in circuit branches where it should be, or detoured into branches where it has no business, is thus definitely established. A common *static* test, such as the measurement of operating voltages and currents, cannot permit any such definite conclusions, although the static test may be used as a follow-up process to detect defective components after the dynamic test has isolated and identified the circuit disorder.

Aside from diagnosing trouble, the dynamic test, of course, has value in the checking of performance of amplifiers. And while remaining unchanged in nature, it becomes in this latter application the recognized procedure for checking the technical performance of an audio system.

REQUIRED INSTRUMENTS

In order to perform the tests, the sound Serviceman will need the following items:

- (1) A good audio oscillator. This may be either a beat-frequency oscillator or one of the lately-introduced resistance-capacity units, as the operator desires. This instrument must be capable of covering the entire A.F. spectrum; i.e., from 20 cycles/second to 20,000 cycles/second,

preferably in a range that is continuously variable. The output voltage characteristic of the oscillator must be substantially flat. Most commercial instruments will deliver an output voltage (determined by the setting of the output attenuator) which does not vary more than 1 db. or so between 100 c.p.s. and 10 kc. Above 10 kc. and below 100 c.p.s. there is usually a drop amounting to approximately 2 db.

- (2) A good vacuum-tube voltmeter with high and low ranges. This type of instrument is recommended instead of the more familiar copper-oxide rectifier type of A.C. voltmeter because measurements will be made throughout the A.F. range, and the exploring voltmeter must, therefore, have excellent frequency response. Any frequency error possessed by the usual V.-T. voltmeter is negligible in the audio spectrum. If the instrument has not been provided with an isolated input circuit, a mica fixed condenser of 0.01-mf. capacity should be connected in series with the "high" input lead to isolate the instrument from D.C. voltage components in the various high-voltage amplifier circuits.

- (3) A variable load resistor which may be adjusted in ohmic value to the rated load impedance of the output tubes or output impedance of the secondary winding of the output transformer. This resistor will be connected to the output circuit in place of the speaker for most measurements, unless otherwise indicated by the instructions.

- (4) A cathode-ray oscilloscope with internal sweep oscillator and axis ampli-

fiers, or in its stead a distortion per cent meter.

Most up-to-date service shops will have the equipment just listed included in their regular test gear. If each of these items is not already owned, all should be purchased, since no man advertising his skill as a P.A. Serviceman is stating facts if he claims to be able to give complete amplifier inspections without them.

TESTS PERFORMED

In the dynamic inspection of any amplifier, the following tests are made:

(1) The audio signal is traced through the entire circuit, observing its presence, loss, or character as it passes through successive audio-frequency stages.

(2) The gain of each stage is individually checked and recorded in voltage or decibel units.

(3) The gain of the entire amplifier is measured and similarly recorded.

(4) The distortion percentage of the entire amplifier or individual stages is checked, or (if the operator's equipment does not permit taking the actual percentage figure) the presence of distortion is detected qualitatively.

(5) The frequency response (fidelity) of the entire amplifier, any of its channels, or speaker is determined.

(6) The condition of each transformer is determined as a routine matter.

(7) Resonant points are localized in speaker, chassis, cabinet, or attachments; and—

(8) Actual power output is measured with minimum signal voltage necessary to maintain this output.

The manner in which the various tests are made will be considered and explained separately in the paragraphs which follow.

SIGNAL TRACING

Figure 1 illustrates a conventional amplifier circuit which will be used in our various explanations. This is an arrangement commonly found in the field and it embraces a high-gain pentode input suitable for high-quality, low-output microphones, a triode voltage amplifier which is of the shunt-fed plate variety, a push-pull triode "driver" stage, and a push-pull power output stage employing high-quality triodes, such as the 2A3. Class A operation will be assumed throughout. Degeneration is introduced through the expedient of a special winding on the output transformer which connects back to the return lead of the primary winding of the first interstage transformer, T1. For purposes of simplicity, the heater and power-supply circuit wiring has been omitted.

The audio oscillator will be connected to the input terminals of the amplifier, tuned to a suitable frequency, its voltage adjusted to a reasonable level by means of the vacuum-tube voltmeter, and the various numbered points throughout the amplifier checked with the meter for presence and strength of the signal.

Connect the output terminals (high-impedance posts) of the audio oscillator to amplifier terminals 1 and 2. Turn the attenuator in the oscillator to zero. Disconnect the speaker terminals 25 and 26 and connect the load resistor to these posts, having preset the resistance to match the impedance of the winding connecting to terminals 20 and 21. The watts rating of this load resistor must be at least twice the power output expected from the output stage.

Switch-on both oscillator and amplifier and set the control attenuator so that the vacuum-tube voltmeter temporarily connected between 1 and 2 is only slightly deflected

Fig. 2. Block diagram of component arrangement for making gain and frequency-response tests of A.F. amplifiers.

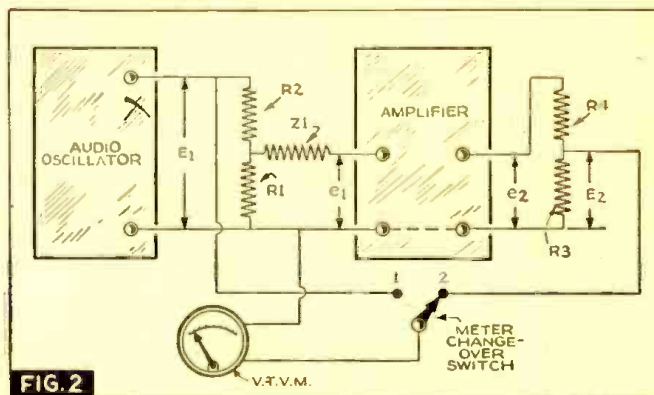

on the 1-volt range when the oscillator is set to 400 cycles. It may be necessary to insert a calibrated potentiometer between the oscillator output and terminals 1 and 2 in order to reduce the input voltage to a low value to prevent blocking of the amplifier stages. The V.-T.V.M. is then connected across the entire potentiometer and the oscillator output adjusted to 1 volt. The voltage selected at this point for application to 1 and 2 will be a millivolt or less.

Allow the "low" V.-T.V.M. terminal to remain connected to chassis ground, such as at terminal 2, and explore the circuit with the "high" lead, which should be shielded along with the test probe for this operation.

Touch the exploring probe to 1-A. If the input condenser is not open, a reading will be obtained on the meter. If, however, the input signal is very low (a millivolt or less) there is apt to be no reading, and the attenuator in the oscillator may be temporarily advanced sufficiently to cause a readable deflection. If there is still no reading, the input condenser is open. The attenuator in the oscillator should then be returned to the original test position.

The probe is then moved to point 3 which is the plate terminal of the first tube, V1; and if this tube is operating, the signal will be present at this point. Moreover, since amplification has taken place within the tube, the voltage should be considerably higher than at 1 or 1-A.

A check at 4 will indicate whether the coupling condenser between the plate of V1 and control-grid of V2 is operating. "No signal" will indicate that this condenser is open. If the signal is present, its voltage level should not be decidedly different from that observed at 3.

Transfer the probe to 5 and advance the gain control in the control-grid circuit of V2 to maximum. Here the signal voltage should be the same as at 4. Now, slowly reduce the setting of the gain control, observing that the meter reading falls proportionately according to the taper of the control. If the meter should cease to read at any point at which the control is set, an open in this resistor is indicated. Should there be no reading at all when the control is at maximum and the probe is at the control-grid of the tube, then the lead from control arm to grid is disconnected, the arm is not making contact with the resistance unit, or the resistance terminal at the "high" end has become disconnected.

When the meter probe is placed at point 6, a larger signal will be observed if the triode V2 is amplifying. No signal, a signal voltage of the same level as that observed at 5, or a signal weaker than that observed at 5 indicate faulty tube action. This may be traced by a static test either to a faulty tube or plate or cathode resistors or condensers, loss of plate or heater voltage, or defective socket.

With the test probe at 7, the condition of the coupling condenser between the plate of V2 and the primary winding of T1 will be checked. Here the voltage should not differ greatly from that observed at 6.

The voltage is noted carefully at 7. The low probe is then removed from chassis ground, and connected to 9, while the high probe is touched to 8. Here, the voltage indication should be somewhat larger than that obtained at 7, the difference indicating the turns ratio of the transformer, T1. Voltage readings taken between 8-and-12 and 9-and-12 should be identical if the center-tap of the T1 secondary winding is correctly placed and there are no shorted turns in the secondary winding.

The meter probes are now transferred to points 10 and 11 where a much increased voltage should be observed if tube V3 is amplifying. The same check may then be made on tube V4 by connecting the meter between 11 and 13. Slightly dissimilar readings obtained here may indicate unmatched tubes or a displacement of the T2 center-tap.

With meter probes at 14 and 15, one-half of the secondary winding of transformer T2 is inspected. The ratio of voltages obtained at 10-11 (or 11-13) and 14-15 indicates the 1/2-primary to 1/2-secondary turns ratio. The other half of the secondary winding is checked with the meter probes at 15 and 16.

There is not a great deal of voltage gain in a power amplifier stage, however the probes may be transferred successively to 17-18 and 18-19 to determine if the output triodes, V5 and V6, are operating.

The meter probes are then transferred to 20 and 21, these terminals being connected to the load resistor. The voltage reading here will be considerable and may be used in a calculation of the amplifier power output. The resistor has previously been measured and this value together with the V.-T.V.M. reading may be substituted in the power formula to determine the output watts:

$$P = E^2/R$$

Where P is the audio watts output,

E the V.-T.V.M. reading in volts,

R the load resistance in ohms.

RESPONSE

An amplifier's response is a measure of its fidelity or ability to reproduce faithfully the music and speech delivered to it by the microphone. The response test is very important, therefore, in establishing the quality of an audio system or in determining the effect of defective or poorly designed parts and circuits. There is neither mystery nor magic to a good response test. Lack of information, more often than lack of apparatus, prevents the more frequent taking of such data by P.A. Servicemen.

Figure 2 illustrates the connections employed when the amplifier response is in-

New CUSTOM-BUILT
PROFESSIONAL
RECORDING AMPLIFIERS

Designed by
A. C. Shaney

Now you can make records to equal or exceed the performance of commercial pressings with these new custom-built recording amplifiers. Available features include; response ± 1 db 20 to 20,000 cps, expander-compressor, high and low frequency equalizers and dialogue filter for each input channel, separate monitor channel, direct current heater supply, plate circuit meter, vacuum tube VU meter, universal output for crystal or magnetic cutter, choice of number and type of input channels for microphone, play-back, radio, dubbing, and talk-back. Send your rough specifications or requirements for quotations.

AMPLIFIER CO. of AMERICA
17 W. 20TH STREET, NEW YORK, N. Y.

undistorted power output is obtained from the amplifier.

The meter is switched back to the input circuit, the oscillator returned to zero frequency, and the stage is set for the response test. The amplifier gain control is at maximum.

The oscillator frequency is increased from approximately 20 cycles through the range to 20,000 cycles in small steps (the smaller the better). The input voltage to the amplifier is kept constant by readjusting the oscillator attenuator to restore the original V-T.V.M. reading when the meter is on the input side.

At each new frequency, the meter is switched to the output circuit, its reading noted and recorded, whereupon it is switched back again to the input circuit.

After the entire frequency range has been covered, the operator should have a large list of frequency readings and the corresponding output voltages. And if these two sets of values are plotted in a graph, the result will be a frequency-vs.-output voltage curve, which is a *response curve*. Ideally, this curve should be flat and horizontal. The more closely it resembles a straight line, the higher is the fidelity of the amplifier. Pronounced dips or peaks at certain frequencies indicate accordingly high or low response at those frequencies, conditions which disclose accentuation or attenuation of certain notes by the amplifier. Poor frequency response may be traced directly to bad tubes, poor components, improper operating voltages, etc., by checking the fidelity of separate stages and transformers.

The foregoing inspection is one of the response of the entire amplifier. Individual stage response may be similarly checked by connecting the high-impedance output of the oscillator to the unconnected grid-input circuit of the stage under test, connecting the vacuum-tube voltmeter so that it may be switched between the input and output circuits, and proceeding as explained in the immediately foregoing paragraphs. If there is a plate-circuit transformer in the stage, it must be included in the output circuit by connecting the meter across its secondary.

Individual transformers may be checked separately by feeding the oscillator voltage into the unconnected transformer primary winding, and arranging the meter to be switched from primary to secondary. The secondary voltages for a constant input (primary) voltage are then recorded for a large number of frequency settings, as already described.

Where poor response is traced to 1 or 2 stages, a static test may be applied to determine the efficiency of their tubes and operating voltages, condensers and resistors.

GAIN

With all connections made as explained under *signal tracing*, it will be remembered that increased voltages were observed as the meter probe was moved from point to point through the amplifier circuit. It is the ratio between these successive voltages that expresses amplification or *gain*.

For example, when the signal is fed into terminals 1 and 2 (Fig. 1), a certain voltage is read at 3, but a considerably higher reading is obtained at 6, indicating that amplification has been provided by the tube V2 and its coupling components. The ratio of these two voltages (or their quotient) is an expression of the voltage gain, or amplification of the V2 stage. For example if the point 3 reading is 1 volt and the point 6 reading 10 volts, the gain of the V2 stage is 10. The gain expressed

vestigated. While the oscillator might be connected to the amplifier under test through an ordinary potentiometer, which will be satisfactory in most cases, the attenuator shown will be much more desirable for exact work.

The vacuum-tube voltmeter is connected to show the voltage across the entire attenuator, which is to say E1. Z1 is numerically equal to the amplifier's input impedance. The voltage delivered to the amplifier input terminals may be determined from the equation:

$$e_1 = \frac{E, R_1}{2(R_1 + R_2)}$$

Since the vacuum-tube voltmeter must be employed alternately to measure input voltage and output power, a single-pole, single-throw switch has been included to transfer the meter from one circuit to the other. The actual output voltage, from which the power output is determined, is:

$$e_2 = \frac{E_2(R_3 + R_4)}{R_3}$$

R3 plus R4 are equal in D.C. ohms to the impedance of the output transformer winding across which they are connected in series.

The oscillator is set at zero frequency and the connections made as shown in Fig. 2. The vacuum-tube voltmeter is then switched to the input position and the oscillator attenuator set to deliver voltage at some convenient setting of the oscillator frequency (e.g., 400 cycles) at the same level used in signal tracing. The meter is then switched to the output position and, with the oscillator delivering 1,000 cycles, the input voltage is adjusted until maximum

FREE!

HAMMARLUND
NEW "41"
RADIO CATALOG

The latest Hammarlund catalog with complete data, illustrations, drawings and curves on the entire Hammarlund line. Address Department RC-5-1 for your free copy.

HAMMARLUND MFG. CO., INC.
424-438 West 33rd Street, New York City

AMAZING VALUES
DIRECT FROM THE MANUFACTURER

Model No. 90 Velocity Microphone represents the finest type of microphone for all around use - broadcasting, orchestras and general public address work.

Output level Minus 52 DB. Input - direct to grid. Frequency response 40 to 12,000 C. P. S. Complete with 25 ft. cable detachable plug.

This is but one of the dozen of microphones, units, trumpets, baffles, etc. which we now offer direct to sound men, dealers, amateurs, etc. at amazingly low prices. Send your order and get literature of our other items.

Only \$9.95
LIFETIME WARRANTY

LIFETIME CORP. 1825 ADAMS STREET TOLEDO, OHIO

LIGHT BEAM TRANSMITTERS

Talk over a light beam. Very mystifying and amusing. You can even talk across the street to your chum. Kit consisting of 23A lamp for transmitting, and photo cell for receiving, together with drawings and circuit diagrams for building necessary amplifiers, complete for \$25.00. Complete amplifier and lamp for transmitting, \$10.00. Complete amplifier with PE cell for receiving, \$15.00. Distances up to 50 ft. can be covered. Phonographs, microphones, or radio can be played over the beam. We can also supply wireless communicators at \$9.00 per unit, or \$18.00 per pair. These will talk over distances of a block or more if the light wire is common. Prices good only while present supply lasts.

ELECTRONIC PRODUCTS CO., St. Charles, Ill.

by the readings taken at 6 and 14-16, however, is an expression of the gain of tubes V3 and V4 and also transformers T1 and T2. Transformer gain is equivalent to the turns ratio.

Starting at the output circuit of the input stage of an amplifier, the gain per stage may be taken throughout, finally reading the gain of the entire amplifier as the ratio of the actual volts (or millivolts) signal input and the volts output across the load resistor.

DISTORTION

We have assumed that all tubes in the amplifier shown in Fig. 1 are biased to operate as class A amplifiers. This would indicate that all direct plate and cathode currents are constant even during actual signal operating conditions.

Distortion may be detected, although its percentage may not be measured thereby, by increasing the signal input delivered by the oscillator and watching for a shift in plate current as indicated by increase in the voltage drop across cathode resistors. The vacuum-tube voltmeter, set to read D.C., is used in this operation and is connected successively across the various cathode resistors by connecting between chassis ground and the points 22, 23, 24 and 27 (filament center-tap). As long as the input voltage does not exceed the value necessary to establish full output at the speaker or load resistor, there should be no increase in plate current or cathode voltage.

For more accurate measurements of distortion and obtaining of the actual percentage, it is customary to employ a cathode-ray oscilloscope or Percentage Distortion meter. The latter device is connected in the output circuit of the amplifier or stage under test, a sine-wave voltage fed into the input circuit, and percentage reading obtained directly. (The construction of an inexpensive meter for such measurements may be described in a forthcoming issue of *Radio-Craft*.—Editor)

The oscilloscope is similarly connected in the output circuits and a pattern of the actual signal wave as it is delivered by the amplifier (or amplifier stage) is observed on its screen. The percentage distortion may then be determined by studying the variation of the pattern from the true sine wave.

RESONANT POINTS

An otherwise faithful amplifier might emphasize certain notes of the scale because

New

EXTENDED RANGE COAXIAL SPEAKERS

ALL WITH THE SUPERIOR PERFORMANCE INHERENT IN DUAL SPEAKER OPERATION

NEW! HF RANGE CONTROL SWITCH This new feature gives you finger-tip control of response, provides instant adjustment of high frequency range for best results on every record, every program FM or AM.

JAP-60. Professional extended-range high-efficiency model for broadcast and transcription use. Includes Range Control Switch and 2-channel network. 15" size. List price, \$70.00 . . . JHP-52. For high quality extended-range Phono, FM/AM receivers. Includes Range Control Switch and 2-channel network. 15" size. List price, \$46.50 . . . JHP-50. For general extended-range application. Bridging network. Accessory Range Control may be added. 15" size. List price, \$38.50 . . . JCP-40. New 12" size gives coaxial performance at low cost! Excellent replacement unit. Bridging network. List price, \$29.50 . . . Write for Catalog 120.

Jensen

6601 SOUTH LARAMIE, CHICAGO
FM·AM·PHONO
REPRODUCERS



the speaker or certain chassis attachments tend to vibrate at their natural frequencies under the influence of sound. Such resonant conditions may be detected quickly by restoring the speaker connections (25 and 26, Fig. 1), feeding the oscillator into the amplifier input terminals (1-2), carrying the oscillator slowly through the entire audio range, and listening carefully for pronounced intensifications at certain frequencies. Speaker resonant points will generally be of 500 cycles or lower, headphone diaphragms at approximately 1,000 cycles, chassis parts and loose tube shields at 2,000 cycles or higher, and cabinets of heavy wood or composition materials at 100 cycles and lower.

OILCAN FOR "INACCESSIBLE" PLACES

● FOR those hard-to-get-at-places that need oil a hypodermic syringe answers the purpose. The needles can be had in any length and if a fine one is used the oil may be squeezed out in any quantity. Contrary to general belief there is no restriction on the sale of these instruments.

Watchmakers can use the instrument by attaching the needle to a glass tube only, without the syringe, and depending on capillary attraction to deliver a spot of oil wherever the end of the needle touches.

CHAS. W. GREEN

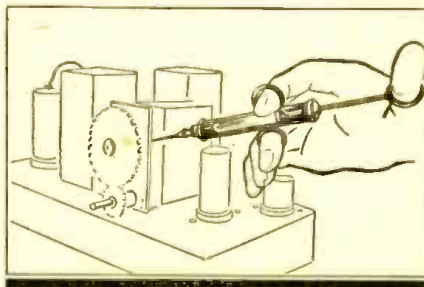

NEXT MONTH . . .

A commercial laboratory, speaking from the angle of Crystal Microphone design and construction, comments on the article, "Modern Microphone Technique," which appeared in the February, March and April, 1941, issues of *Radio-Craft*. Don't miss this article!

A "LAB" to fit your pocket



Readrite
RANGER

MODEL 739

\$9.90
Dealer Net Price

A.C. D.C. VOLT-OHM-MILLIAMMETER

Pocket Volt-Ohm-Milliammeter with Selector Switch. Molded Case. . . Precision 3-Inch Meter with 2 Genuine Sapphire Jewel Bearings. AC and DC Volts 0-15-150-750-1500; DC MA. 0-1.15-15-150; High and Low Ohm Scales. . . Dealer Net Price, including all accessories, \$9.90

MODEL 738 . . . DC Pocket Volt-Ohm-Milliammeter, Dealer Net Price . . . \$7.50

WRITE FOR CATALOG

SECTION 516 COLLEGE DRIVE

READRITE METER WORKS, Bluffton, Ohio



Mr. Longley's mobile sound apparatus, preparatory to being set up for a job.

In 10 minutes two men can set up these sound projectors, as the author here describes.

ULTRA-MOBILE P.A. SYSTEM

Mobile sound systems incorporate features peculiar to this type of operation, as author Longley here discloses. Also described in this article on a gas-engine powered sound system are the means which may be employed to obtain more mobility than is usual for equipment of this type.

EDWIN F. LONGLEY

MANY times during the 3 years the author was selecting, building, testing and operating the Ultra-Mobile Public Address System here described, he had hoped to find a really comprehensive article, on an entire sound system, in which the selection, design and construction with some of the difficulties encountered and their solution were clearly explained.

An efficient, ultra-mobile sound system is made up of 6 principal units which will be taken up in order and the reason of selection with a few of the difficulties of operation discussed.

THE AMPLIFIER

The *amplifier* is the very heart of the entire system; on its reliability, versatility and output fidelity depend the success or failure of the whole venture.

From my experience in the field certain minimum requirements are necessary, such as 2 independently-controlled high-impedance microphone inputs, 1 phonograph input, delayed automatic audio volume control, and a floating rubber set plate assembly to protect the voltage amplifier tubes from external vibration.

The ability to mix the microphone input with that of the phonograph while not absolutely necessary adds to the pleasing operation of the system on some occasions and is well worth the extra control.

The fidelity curve should be the finest obtainable, i.e., ± 1 db. from 30 to 20,000 cycles at 50 to 60 watts with distortion of 2½%, or less. This specification necessitated a specially-built amplifier but the extra expense is worthwhile especially when booking repeat business.

In our search for an amplifier we were very much surprised to note how few amplifier manufacturers made any provision for eliminating external vibration which is the chief cause of tube microphonism in

high-gain circuits. This feature is absolutely essential in a *mobile* outfit because of road shock and minute vibration set up by the A.C. power plant usually installed within a soundproof compartment built into the truck body.

Amplifiers without vibration-protected preamplifier tubes give forth all kinds of strange sounds when using the microphone while the truck is in motion.

In public address work *delayed automatic audio volume control* is also obligatory as so many speakers insist on crowding the microphone and raising their voices to shouting levels while others become excited and step from side to side causing the sound output to vary greatly. We have had occasions when A.A.V.C. in combination with manual control could not keep the output level constant.

In some locations, the output level can not readily be heard by the control operator, so some visual volume indicator must be used. We prefer a milliammeter in the plate supply to the output tubes for by this means a constant check may be kept on both volume level and power tube condition.

A.C. GENERATING PLANT

The static A.C. load of both amplifier and record turntable total about 275 watts so a 350-watt, self-starting, 60-cycle plant is used.

This single piece of apparatus is the hardest to make work properly, as we found that when a fully-loaded A.C. generating plant is operated in a confined space, such as a soundproof compartment within a truck body, proper engine cooling is a very difficult problem.

In order to obtain reliable plant operation a length of 6-in. stovepipe was riveted to the engine flywheel shroud and extended to a port in the truck back. This pipe supplies cool air to the flywheel fan. Lastly, a

6-volt electric fan was placed so as to force a stream of air directly onto the engine cylinder and thence out a 21-in. long x 16-in. high opening.

Insulating the truck frame from vibration set up by the A.C. plant was accomplished by floating the plant on 4 double sets of springs.

SOUND REPRODUCERS & PROJECTORS

In the selection of sound *reproducers* the P.A. specialist has 2 general types to pick from, i.e., (1) the dynamic cone speaker; and, (2) the 6-foot exponential horn with a driving unit composed of a metal diaphragm with voice coil attached.

We found that although the exponential driving unit gave fine, crisp reproduction of voice frequencies it was woefully lacking in the low frequencies so essential to fine musical rendition; thus in order to fully utilize our amplifier's fine frequency curve, 4 Jensen type A-12PM reproducers were selected, the pair facing forward equipped with waterproof cones.

In sound *projectors* there are 3 types to select from, namely: (1) wall baffles; (2) 6-foot exponential trumpets with driving units; and, (3) giant parabolic projectors with dynamic speakers.

The point to take into consideration here is that a given amount of sound energy will fill only a certain number of cubic feet of air and that the length of projection varies in inverse ratio to the width of the angle of diffusion; in short, we have the question: what type of projector will best cover the average crowd?

Wall baffles which have a wide angle of diffusion, a little under 180°, have a limited projection and are only suited to cover small sidewalk gatherings.

Exponential trumpets on the other hand project a highly concentrated beam of sound

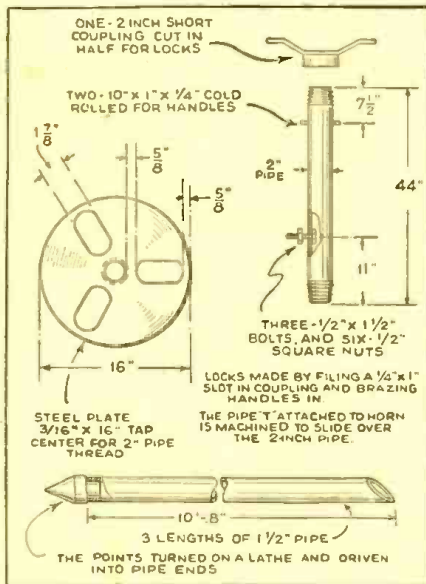

Details of the method of locking together the horn assemblies.

easily heard over a mile away but their angle of diffusion is so limited that a bank of several is needed to evenly cover a small crowd.

The exponential trumpet although the most generally used is also the most ill-suited to ordinary P.A. use as it is totally unnecessary to throw sound over a distance greater than that over which the eye can readily distinguish the speakers (orators, etc.).

The final selection was 4 giant parabolic projectors equipped with well-damped backs (necessary in order to use the microphone on the truck platform). These horns have

an angle of diffusion less than wall baffles but greater than exponential trumpets with a length of projection in proportion (about 600 to 800 feet).

When these 4 projectors are set in pairs on 2 tripods placed either side of a speaker's platform, their area of coverage nicely fits that of most assemblies, large or small.

For public speaking, 2 velocity microphones wired in parallel and spaced 7 1/2 ins. on centers give fine results, as this arrangement allows the orator to turn from side to side thus adding to the naturalness of the program.

A velocity model equipped with an "acoustic compensator" is ideal for distant pickup or for close-talking conditions.

At track and field events where announcements are made from the truck platform a dynamic type is used as this type is much less susceptible to wind conditions than the velocity type.

ULTRA-MOBILITY

Four swivel horn mountings consisting of a flange and a length of 2-inch pipe fitted with a quick-change winged lock, are bolted to the truck platform. Each horn has a 2-inch pipe T attached which allows the horn to be rotated in any direction desired, and locked in position, or the lock may be released and the horn lifted off.

In order to properly handle rallies, dedications, band concerts, etc., the horns are set up in pairs on two 13-ft. tripods. The tripods fold up and are carried from location to location strapped to the platform in between the horn mounts interfering in no way with the operation of the sound system for street advertising.

This feature of ultra-mobility (the tripods can be set up, and the horns transferred from truck top to tripods, by 2 men in less than 10 minutes) will enable the wide-awake P.A. specialist to obtain many jobs over competitors not so equipped.

For Ideal HOME RECORDING



Insist On Meissner Quality!

Engineered for superior performance—ultimate fidelity in recording—lifelike quality in reproduction—designed for those who want nothing but the best!

Outstanding appearance—motor-board and arms in brown crystal finish—panel plates of two-toned etched brass—modern, styled case with bronze fittings—sturdy leather handle—a professionally artistic ensemble!

Complete—ready for use—5-tube built-in amplifier—may be used as Public Address system! Includes crystal microphone—mike and power cord pack into space beneath name-plate. Uses powerful magnetic cutting head and highest grade crystal pickup. Ample record storage space in removable cover.

No. 9-1045 Phono-Recorder, List. \$59.50

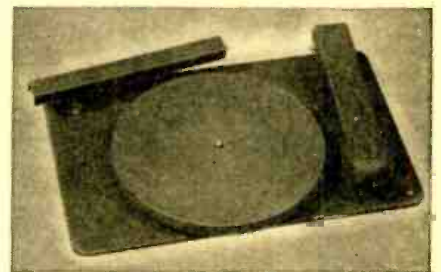

MOTOR TURNTABLE UNIT

Complete dual-arm mechanism for any installation; similar to unit used on above Recorder; powerful, constant-speed motor for 110-volt, 60-cycle operation. Heavy steel base; brown crystalline finish.

Low-impedance magnetic cutting head connects to voice-coil secondary of output transformer; high-impedance crystal pickup. Furnished with complete instructions.

No. 9-1039 Turntable Unit, List. \$31.50

Write Today for Free General Catalog

Address Dept. C-5



INDEX TO "RADIO-CRAFT" ARTICLES ON SOUND

- Modern Microphone Technique—Part I, The Microphone (Feb. '41); Part II, The Microphone and Its Relation to the Amplifier (March '41); Part III, The Microphone in Action (April '41).
- Home Recording—Theory and Practice of Sound-on-Disc (March '41).
- A New A.F.-Drift Correcting, Direct-Coupled F.M. 24-Watt Audio Amplifier, Part I (Dec. '40); Part II (Jan. '41); Part III (Feb. '41).
- Smallest Radio Tubes! (Article includes hearing-aid circuits.) (Feb. '41).
- "Fantasia" Introduces "Fantasound" (Feb. '41).
- Sound Engineering (Selected items from this monthly department):
- 4-Watt A.C.-D.C. Amplifier (April '41).
- 4-Tube Parallel Push-Pull Beam-Power Output Stage (Feb. '41).
- Design Data for Bass Reflex Enclosures (or "Infinite Baffles") (Sept. '40).
- Mixer Circuits (July '40).
- Hearing-Aid Battery Amplifier (April '40).
- 25-Watt High-Fidelity Amplifier, with 4-Channel Electronic Mixing (March '40).
- 8-Watt Direct-Coupled Amplifier (Jan. '40).
- "Wireless" 3-Tube Phono-Oscillator (Jan. '41).
- Recording Pointers (Jan. '41).
- *Funeral-Parlor Sound System (Dec. '40).
- Recording-Playback Amplifier Has Direct-Coupled Output Circuit and Equalized 30-Watt Output (Nov. '40).
- Dynamic Phono Pickup for Both Lateral and Vertical Recordings! (Nov. '40).
- Calculating Impedance at a Given Frequency (Nov. '40).
- How to Make a Versatile Miniature-Battery-Tube Audio Amplifier (Oct. '40).
- New 5/8-Volt Tubes (Article includes hearing-aid circuit) (Oct. '40).
- "Balanced" Audio Spectrums (Sept. '40).

- Photoelectric Phono Pickup (Sept. '40).
- Constant Groove-Speed Recording (Aug. '40)
- 20-Watt Booster Amplifier—for Radio Receivers, Low-Power P.A. Systems, Etc.
- Resistors and Condensers for Use in Audio-Frequency Amplifiers (July '40).
- Specialized A.F. Tubes (July '40).
- *P.A. System for Ball Games, Etc. (July '40).
- *Church Sound Set-up (July '40).
- "Transitional" P.A. System (July '40).
- A Triode Direct-Coupled 15-Watt Amplifier—with Non-Frequency-Discriminating Scratch Suppressor (July '40).
- "Enhanced" Stereophonic Sound (July '40).
- The Use of Dual Loudspeakers (June '40).
- Speaker Matching Technique (June '40).
- Universal 25-Watt Amplifier Operates from 6-Volt Battery or 110/220-Volt A.C./D.C. Line (June '40).
- Profits in Recording—Part I (May '40); Part II (June '40).
- *Selling and Installing a Call System (June '40).
- The Latest Miniature Hearing-Aid Amplifier (May '40).
- Designing a 60-Watt Direct-Coupled Beam-Power Amplifier (May '40).
- 4 Thumb-size Pentodes for Hearing-Aids (Article includes hearing-aid circuits) (May '40).
- How One Sound Man Drums-up Business (May '40).
- Radio-Sound Studio in College (May '40).
- *Convention Sound System (Article includes details for constructing an infinite baffle.) (May '40).
- The ABC of Db., VU, Mu, Va, Gm and Sm (April '40).
- How to Select and Place Sound Equipment—Part I, Microphones (Jan. '40); Part II, Loudspeakers (Feb. '40); Part III, Placement of Equipment (March '40).
- Articles on Sound in Past Issues (An index to articles in issues prior to the issue of May '40).

*Selected from the series, "Case Histories of P.A. Sales."

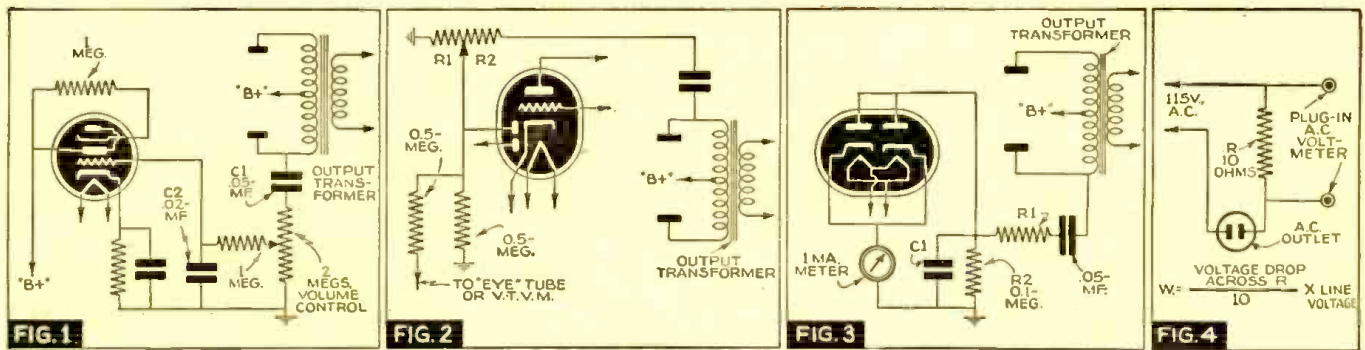

ADDING AN "EYE" TO A.F. AMPLIFIERS

— and other Practical Ideas

The following article travels along an almost unbeaten path in that it describes a series of circuits designed to achieve additional useful functions from existing radio equipment with minimum additional apparatus.

HAROLD DAVIS

ALTHOUGH not generally known, an electron "eye" indicator can be added to any audio amplifier without adding a rectifier tube. This is because the audio signal is pulsating D.C. and not A.C., and all that is needed to make it work an "eye" is a little filtering.

Referring to Fig. 1, if a 1- or 2-meg. control is used as a voltage divider, the eye can be adjusted to where it will just close on the amount of volume needed to do a certain job (recording, for instance). Then the volume control on the amplifier can be advanced to give this required output. Condenser C1 is the blocking and coupling condenser and C2 is a filter. The cathode resistor and condenser can be omitted, and the cathode may be grounded, although generally used in radio sets to control the sensitivity of the eye. The arrangement makes a handy output meter.

The writer strongly recommends the use of such an "eye" attachment as it makes possible much more precise adjustment of the equipment than is possible when employing merely audible monitoring. For example, in audio circuits designed for reproduction of more than usual fidelity, the need for such visual monitoring becomes increasingly apparent. We believe the circuit suggested here will appeal to many experimenters and sound specialists.

Of course in connection with this circuit as with the other circuits shown in this article, it is necessary to give due consideration to the characteristics of the available power supply equipment and its ability to deliver the requisite additional power. In view of the fact that the circuit suggested here requires an almost inappreciably-small additional total watts power, it is to be recommended for use where the associated apparatus is being operated to close tolerances and where an additional rectifier under these conditions might result in unstabilizing the voltages throughout the system.

USING "EXTRA" DIODE IN DUODIODE-TRIODE

THE extra diode, when not otherwise used, may be connected to perform an entirely different function than that of the other in a duodiode-triode.

The usual practice is to tie these diodes together when only one function is necessary. In this case they may be separated and the extra element used to rectify audio fed back from the following stage or even from the plate of the triode section. The ratio of R1 to R2 as shown in Fig. 2 will control the amount of signal applied to the rectifier. Signals from an entirely different circuit may be fed to this extra diode for rectification, and will often eliminate the installation of a special tube for this purpose.

Like the preceding and following circuits, the diagram shown in Fig. 2 is a "current saver" inasmuch as it affords additional services without the expense of additional tubes. By making the resistors variable they may be adjusted until best results are obtained, their values then may be noted by an ohmmeter check and fixed units of the indicated values substituted for the variable units.

ADDING A METER INDICATOR

TO add a meter indicator to an audio amplifier requires adding a vacuum-tube or some other type of rectifier. The arrangement shown in Fig. 3 employs a duodiode with any old 0-1. ma. meter in the cathode.

The size of R1 controls the amount of signal applied to the diode and should be kept as large as possible because the diode has very low impedance and will load the circuit. If too much loading is noticed, use only one of the diodes and ground the other. Resistance may be added to the cathode in series with the meter to control the meter action if needed. Condenser C1 is made as large as possible without "bass-ing" the amplifier. Resistor R2 may also be varied to give proper deflection.

SIMPLE WATTMETER

SIGNAL TRACERS incorporating wattmeters have made that instrument popular. Wattmeters will show up shorted power transformers, filter condensers, chokes and rectifiers. In fact anything that causes excessive drain on the power supply. A very efficient and simple wattmeter is constructed as shown in Fig. 4.

A 10-ohm resistor, with a capacity of at least 10 watts, is installed in series with the 110-V. line and outlet. Tip-jacks are con-

nected across the resistor so that a copper-oxide rectifier type of A.C. meter can be plugged into them to read the voltage drop across the resistor. The watts power consumed by the load connected to the outlet is the voltmeter reading divided by 10 and multiplied by the line voltage.

Example: The meter reads 7 volts when a certain set is plugged in. Seven divided by 10 is .7, or simply one place pointed off to the left. Hence, .7 times 110 is 77 (watts).*

If an extra A.C. meter is available, it may be wired-in permanently. If a low-resistance A.C. meter is used an error will result due to the parallel resistance offered by the meter.

If no A.C. meter is available, a 6.3 volt pilot light can be interpreted with a little experience gained by plugging-in electric light bulbs of known watts rating and noting the brightness of the pilot lamp.

A set pulling 100 watts will cause a 10-volt drop across the resistor, which will tax the pilot lamp filament resistance, and occasionally one may be lost due to burn-outs. If heavy power consumption is encountered, it may be found advisable to install a 5-ohm resistor alongside the 10-ohm unit and use a double-throw switch to select the desired value. The watts reading, using the 5-ohm resistor, can be found by dividing the meter reading by 5 and multiplying the result by the line voltage.

The lamp or meter must be watched carefully when the set is first plugged-in and is warming up, as a shorted condition in the set will cause an excessive voltage to be impressed on the meter or lamp.

Note that in Fig. 4 a 10-ohm resistor would be connected across the line in the event of a shorted device being plugged into the A.C. outlet. This suggests that both sides of the lightline should be fused, to guard against all eventualities. This is a wise precaution to take in connection with any test circuit that connects to a power line.

(Experimenters are also recommended to the simpler add-on circuits described in the 2-part article, "Servicing 'Orphans' and Private-Brand Radio Sets," in the March and April, 1940, issues of *Radio-Craft*.)

*Subject to power factor correction, but close enough for comparison measurements.

You CAN DEPEND ON

hallicrafters

COMMUNICATIONS RECEIVERS



MODEL S-19R

The Sky Buddy—4 bands, covers everything on the air, from 44 mc. to 545 kc., including the 10, 20, 40, 80 and 160 meter amateur bands. Electrical bandspread. Built-in 5" Dynamic Speaker. 6 tubes. Beat frequency oscillator. Built-in line filter. AVC. Send-Receive and band switches. The Sky Buddy gives superior performance with amazing ease of operation. \$29.50



MODEL S-20R

The Sky Champion represents the best value ever offered in the communications field. 9 tubes. 4 bands. Tunes from 540 kc. to 44 mc. Automatic noise limiter. AVC switch. Stand-by switch. Inertia bandspread tuning. Separate electrical bandspread. Beat frequency oscillator. Battery-vibrapack, DC operation socket. Incorporates all the essential controls for good amateur reception. \$49.50



MODEL SX-24

An outstanding communications receiver value. 9 tubes. 4 bands with a frequency range of from 540 kc. to 43.5 mc. Band 1—540 kc. to 1.730 kc.; Band 2—1.7 mc. to 5.1 mc.; Band 3—5.0 mc. to 15.7 mc.; Band 4—15.2 mc. to 43.5 mc. Frequency stability throughout a wide range of line-voltage humidity and temperature variations. DC operation socket—battery or Vibrapack. \$69.50



MODEL EC-1

All these important communications features at this sensationally low price. 3 bands covering from 545 kc. to 30.5 mc.—(550 to 9.85 meters). Electrical bandspread on all bands. Beat frequency oscillator. Self-contained PM Dynamic Speaker. 6 tubes. AC/DC operation—115/125 volts. Every necessary feature to give the short-wave listener and the amateur an up-to-the-minute communications receiver for only \$19.95

RADIO ELECTRIC

SERVICE CO.



MAIN STORE: CORNER 7th AND ARCH STREETS, PHILADELPHIA, PA.

5133 Market Street
Philadelphia, Pa.
1042 Hamilton Street
Allentown, Pa.

811 Federal Street
Camden, New Jersey
3145 N. Broad Street
North Philadelphia, Pa.

107 W. 6th Street
Wilmington, Del.
9 N. 2nd St.
Easton, Pa.

RADIO-CRAFT for MAY, 1941

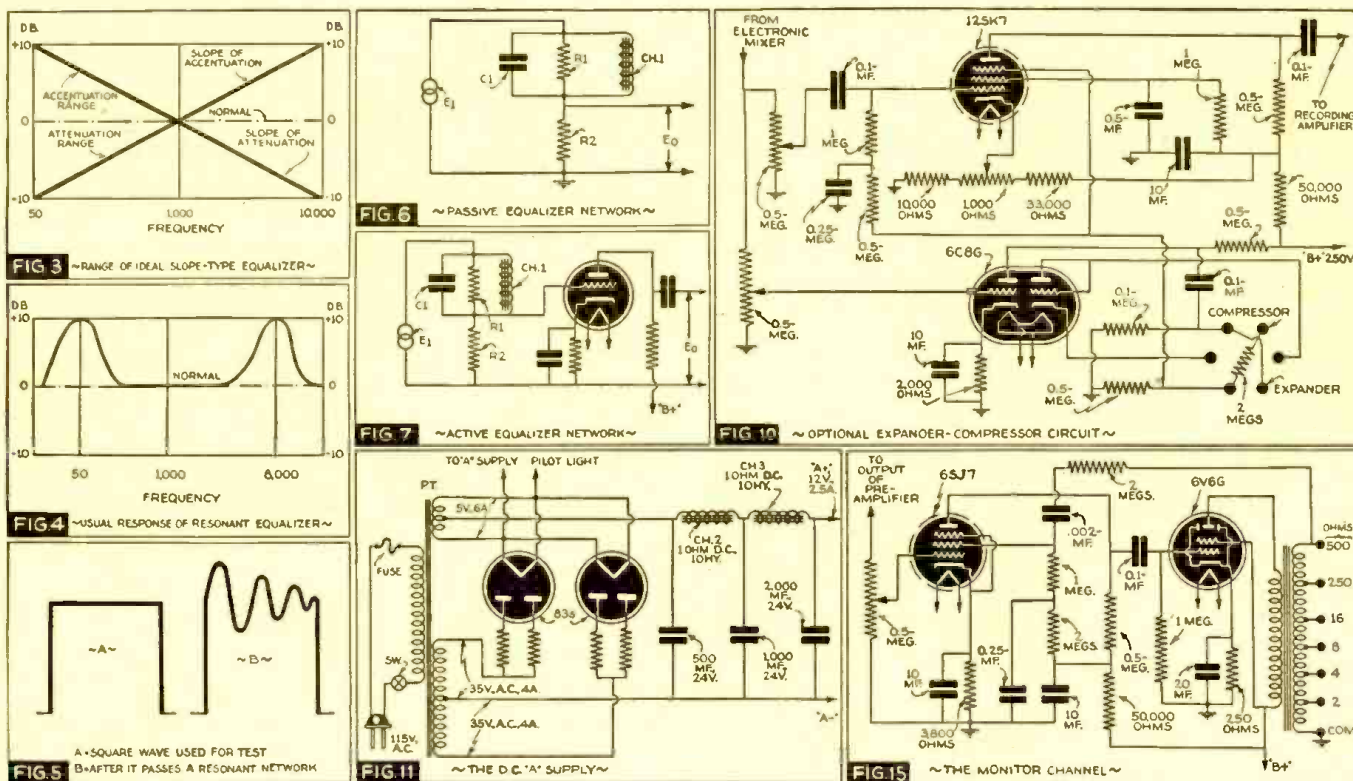

Modern Circuit Features of a Semi-Professional 10-Watt RECORDING AND PLAYBACK AMPLIFIER

A technical discussion of an amplifier specifically designed to fit the needs of the serious-minded recordist, particularly one who has stepped out of the amateur class. Variation in output amplifier provides for choice of 2A3 or 6L6G output tubes.



Fig. 1. The completed Semi-Professional Recording-Playback Amplifier. Identification of the equipment on the 3 panels (reading from left to right): Top Panel: "B" supply pilot and switch; "A" supply switch, and pilot. Middle Panel: off-1p of triodes Nos. 1 and 2; power level VU meter; off-plus 30 VU and 40 VU; (center knob) amplifier gain control. Bottom Panel: consider these controls in vertical rows, the first 5 of which are channel controls, bottom to top, as follows: channel volume control, L.F. control, H.F. control, dialogue filter switch. Row 6: master volume control, monitor volume control, expander control, monitor-compressor switch. The meter is a vacuum-tube VU type; underneath is the VU range selector switch; the 3 buttons underneath read: Monitor, Recording and Playback.

A. C. SHANEY

ONE OF THE most popular questions received from the field is, "What type of amplifier do you recommend for recording, playback and Public Address applications?" Strange as it may seem, no one amplifier can be a perfect recording, playback and P.A. unit because each one of the applications requires a series of specific performance characteristics which do not coincide with the other application. To expect one amplifier to operate perfectly for all 3 applications, is like expecting a man to be a jack of all trades and a master of all.

In order to attain results comparable to commercial studios, it is obviously necessary to use comparable equipment. There is no short cut or skimpy route to accredited commercial performance. To obtain real good records there is no getting away from the fact that a good amplifier is of prime importance. Naturally, all of the other interconnecting components are equally important. A good cutter, microphone, turntable, pickup and tuner are also essential.

It is obvious that the cost of professional equipment would be considerably beyond the reach of the graduate amateur recordist. A careful study, however, of a number of professional recording amplifiers, which have been built in our laboratories, clearly indicates the feasibility of eliminating some of the non-essentials from the mechanical construction and thereby enabling the production of a reasonably-priced amplifier

system capable of producing results equivalent to the much more expensive studio equipment.

It is to be understood, however, that this amplifier is not intended to be constructed from junk-box parts. The nicety of its overall performance depends upon straightforward amplifier engineering and clean-cut mechanical design and workmanship.

THE AMPLIFIER IN GENERAL

Figure 1 shows a photograph of the amplifier mounted in a conventional rack. The system is composed of 3 essential parts. The top panel has the combined "B" supply, bias supply and D.C. "A" supply. The center panel houses the amplifier, VU meter, gain control, plate current measuring switch and VU range switch. The lower panel contains 3 microphone channels, 1 radio channel, and 1 playback channel. Each of these channels has its independent, slope-type high-frequency equalizer, low-frequency equalizer, and dialogue filter.

Included in addition, is a master gain control, an individual monitor amplifier with independent gain control, and expander-compressor control with its associated switch. A vacuum-tube VU meter in conjunction with a range selector, provides for accurate visual monitoring. For simplicity of playback, pre-recording, and monitoring, a Recording-Playback-Monitor switch is incorporated.

INDEPENDENT CHANNEL EQUALIZATION

To understand the elements and arrangements of the preamplifier circuit, a block diagram has been indicated in Fig. 2. It will be noted that each channel has its own set of high- and low-frequency equalizers. This arrangement enables ideal equalization for any type of microphone, pickup and radio program. It also provides for special sound effects equalization and unlimited flexibility, particularly when mixing voice while dubbing.

Slope equalization is differentiated from the more common, *resonant-type* equalizers, in that it provides for a degree of accentuation or attenuation proportional to frequency at the high-frequency end of the audio spectrum, and inversely proportional to frequency at the low-frequency end of the spectrum. A typical slope equalizer response characteristic is indicated in Fig. 3. It will be noted that all settings of equalization within its operating range provide for a linear slope response.

A resonant equalizer, however (which is indicated in Fig. 4), usually provides for broad or sharply-tuned resonant response curves. The latter arrangement is subject to what is known as shock excitation when in sustained oscillations occur, when a tone, rich in the frequency of resonance, is impressed upon the circuit. This produces extreme distortion easily observed when a square wave is passed through the system. Figure 5 indicates the change which occurs in the square wave passed through a resonant network. The oscillation which is imposed upon the top of the wave is the resonant frequency.

The fundamental principle of all equalizers other than the resonant type, evolves itself about introducing losses throughout the entire spectrum and then regaining (for boost) some of the initial losses. For attenuation, an additional loss is inserted. This general type of equalization is known as a *passive network*, and is fundamentally diagrammed in Fig. 6.

Resistors R1, R2, introduce a fixed loss. Condenser C1 regains this loss at the high frequencies while Ch.1 regains it at the low frequencies. This is known as a fixed high- and low-frequency boost. It is passive because it does not add to the overall gain of the network.

An *active network* is similar to the passive type with the exception that an additional stage gain is added at the output of the filter (Fig. 7), so that the unequaled output Eo is equal or greater than the input E1.

DIALOGUE FILTER

The *dialogue filter* is a simple method of introducing an additional low-frequency loss to cut low frequencies from speech. This is highly desirable for maximum intelligibility.

It should be remembered, that each channel is equipped with a set of identical but entirely independent high-frequency and low-frequency equalizers as well as a dialogue filter.

The desirable degree of maximum equalization seems to be an arbitrary point among many amateur recordists. It has been erroneously believed that as much as 20 db. would be desirable for adequate compensation when recording towards the center of a 16-in. record at 33 1/3 r.p.m. While such a high difference of equalization may be desirable under certain conditions, it is generally dangerous.

The amount of power fed to a cutting-head after equalization, may be calculated from the following formula

$$P = A \cdot 2 \frac{\text{db.B}}{3} \text{ or } P = A \sqrt{2\text{db.B}}$$

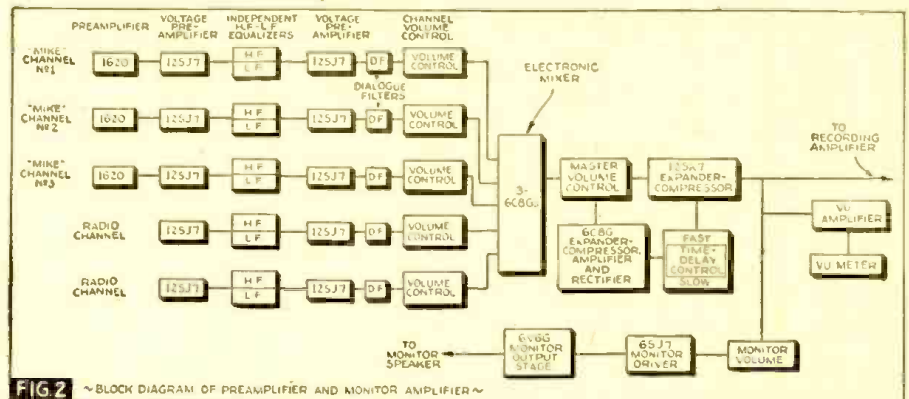

FIG 2 ~ BLOCK DIAGRAM OF PREAMPLIFIER AND MONITOR AMPLIFIER ~

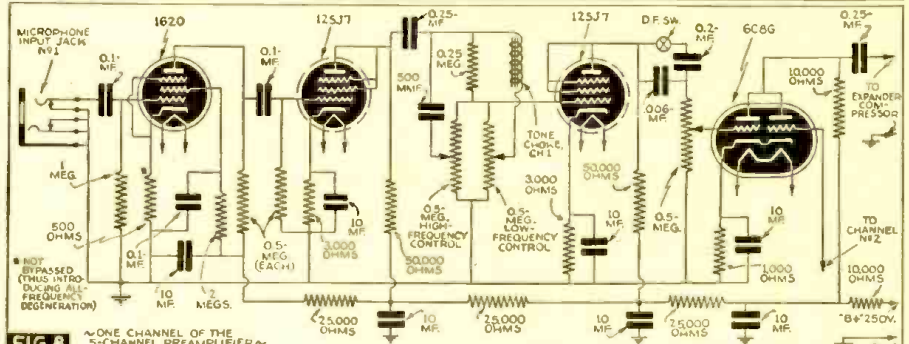

FIG 8 ~ ONE CHANNEL OF THE 5-CHANNEL PREAMPLIFIER ~

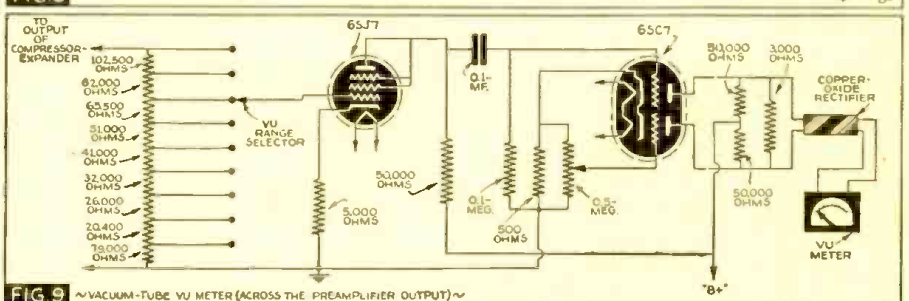

FIG 9 ~ VACUUM-TUBE VU METER (ACROSS THE PREAMPLIFIER OUTPUT) ~

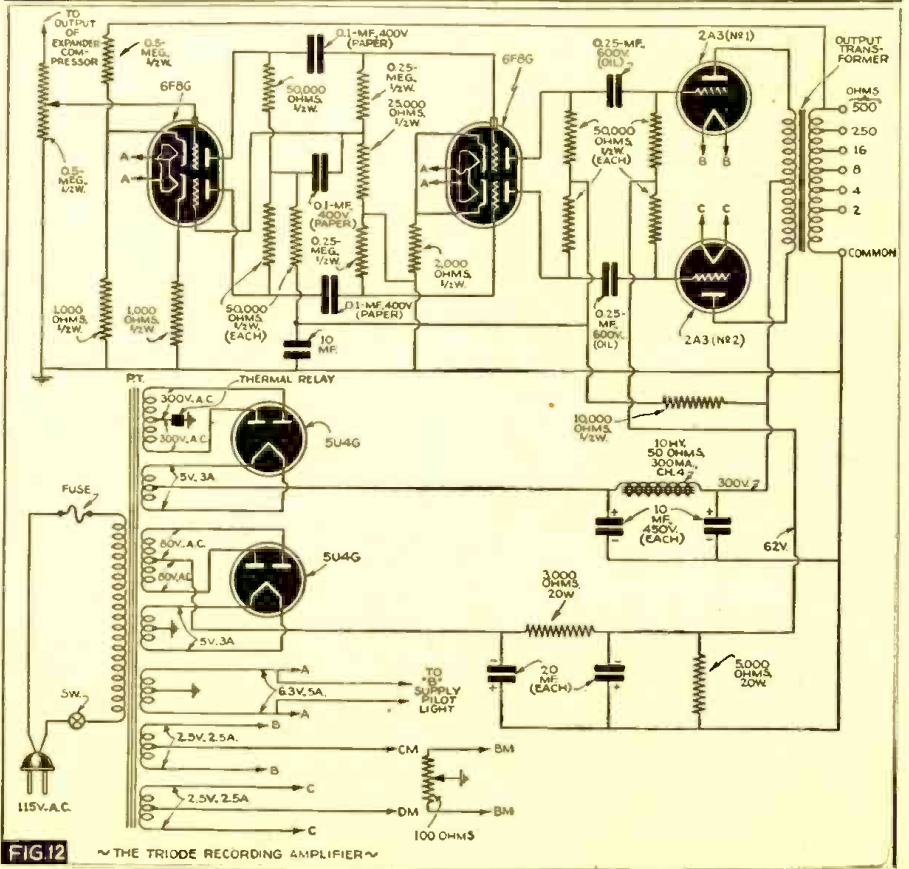

FIG 12 ~ THE TRIODE RECORDING AMPLIFIER ~



EFFICIENCY is the Magic Word
The Reason Why a Single UNIVERSITY REFLEX HIGH EFFICIENCY SPEAKER
 does the work of three ordinary low efficiency speakers.

UNIVERSITY
 Reflex Speakers have highest possible efficiency, far greater than any other type of loud speaker.

Write for new catalogue sheets
UNIVERSITY LABORATORIES
 195 Christie Street
 New York City

NEW AUDIOGRAPH Sound Catalog

AUDIOGRAPH Sound Systems represent the latest in Sound Engineering and Design—a complete line plus pre-tested accessories.

NEW LOWER PRICES
 Outstanding quality and performance at prices that help you meet any competition.

WRITE FOR FREE COPY
JOHN MECK INDUSTRIES
 1313 W. Randolph St., Chicago, Ill.

DATAPRINTS

TESLA-ODUDIN COILS

20c Ea. in order for 10 (Data and Drawings only.)
 36" Sp'k Tesla-Oudin Coil 40c (1 K.W. Exc. Trf. Data incl.)
 8" Sp'k Tesla-Oudin Coil 40c (1/4 K.W. Exc. Trf. Data incl.)
 8" Sp'k Oudin; 110 Vt. "Kick Coil" type.....40c
 3" Tesla Works on Ford Coil.....40c
 1" Sp'k Vibrator Hi-Freq. Coil 40c

NEW! 5 ft. Sp'k. Oudin Coil & Exciter Data.....75c

Induction PIPE & ORE LOCATOR

Induction Type, Data.....40c
 Radio Type.....40c

More DATAPRINTS 40c each!

5 Meter Superhet.	Electric Refrigerator
1/4 Meter Tr. & Rec.	Wheatstone Bridge
20 A.C. Probs. & Ans.	Weld. Transf. 2 K.W.
20 Telephone Hook-ups	Rewinding Armatures
100 Mech. Movements	String Galvanometer
20 Motor Hook-ups	20 Simple Bell Circuits
Television Hook-up	Steel Wire Recorder!
20 Elec. Party Tricks	Water Wheels
Solenoids and Magnets—get list.	Water Turbines
Fry Eggs on Ice!	Photo Cell and Relay
Experimental Photophone	Ring 4 bells: 2 Wires
Radio Control for Models	20 Tesla Tricks
Diathermy Apparatus	Polarized Relay
Inductor Organ	Induction Balance
	Electric Pipe Thawer

Special Prices: 4 prints \$1.00; 10 for \$2.00; Single, 40c each. Get New Catalog 100 A.

The DATAPRINT Co.
 Lock Box 322D, Ramsey, N. J.

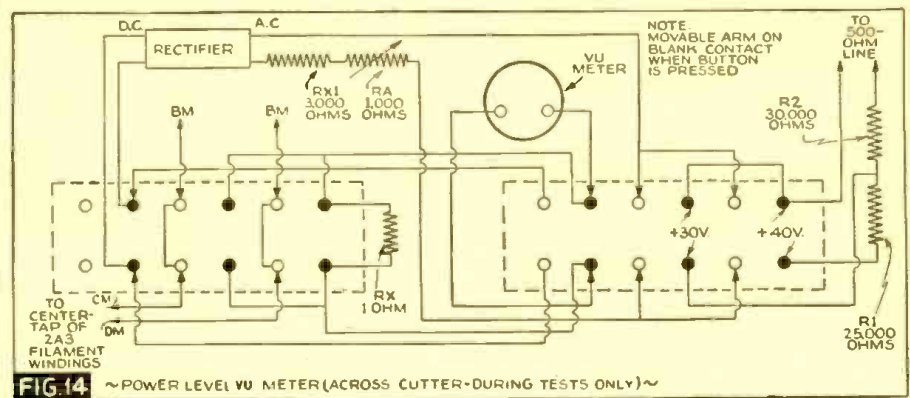

where P = Power output after equalization at equalized frequency
 A = Average output power before equalization
 $db.B$ = Decibel boost at equalized frequency

As an example, if the average level fed to a cutter is 2 watts and a 12 db. boost is set at 10,000 cycles, then

$$P = 2 \cdot 2^{\frac{12}{3}} = 2 \cdot 2^4 = 2 \cdot 16 = 32 \text{ watts}$$

Under this seemingly possible boost of 12 db. 32 watts will actually be fed into the cutter. Under this condition, the average recording amplifier usually overloads or the cutter is damaged. A high boost at the high-frequency end of the spectrum for the inside of 33 1/3 r.p.m. records is usually requested only because the "highs" seem to fall off excessively. A careful analysis of the recording processes employed will disclose why these highs are lost excessively and also why excessive high-frequency boost may not alter the detrimental condition.

RECORD SPEED

The surface speed of a record may be calculated from the following formula

$$S_s = \frac{r.p.m.}{60} \cdot 2\pi R$$

where S_s = surface speed per second
 r.p.m. = revolutions per minute
 R = radial distance from center of turntable to cutter needle.

At the outermost edge of a 16-in. record, the surface speed is approximately 28 ins. per second. When a 10,000-cycle note is impressed, there is approximately 2.8 thousandths of an inch between peaks. With a 2-in. radial distance, however, the surface speed is approximately 7 ins. per second, and a 10,000-cycle tone has nearly 7/10,000 of an inch between peaks.

It should be obvious that unusual precautions must be taken in cutting-needle design in order to prevent successive wave-fronts from cutting into each other. It should be borne in mind that the higher the frequency the steeper is the wave-front, and the slower the surface speed, the steeper is the wave-front.

To add to the complexities, at high frequencies, the cutting needle usually pushes the material from side to side instead of cutting it. Naturally, after the resilient material has been pushed, it will tend to flow back into its original position. This in turn causes an additional high-frequency loss. This latter loss, however, is independent of radial distance and can therefore easily be compensated for by one fixed setting.

The discrepancies caused by variation of radial distances can only be compensated for when unusual design features are incorporated. For example, a very-high-powered recording amplifier should be used (possibly up to 100 watts) together with

a very-high-powered cutting head (which should handle up to 100 watts).

OTHER CIRCUIT FEATURES

The Input Channels—Figure 8 indicates circuit diagram of one of the 3 microphone input channels. It will be noted that electronic mixing is used for mixing 5 channels.

The Vacuum-Tube VU Meter—In order to monitor the output of the voltage amplifier without introducing any distortion, a special type of vacuum-tube VU meter has been developed (Fig. 9). This VU meter has ballastic characteristics as standardized by N.B.C., C.B.S., and Bell Labs. Its essential difference, however, is that it has a relatively high impedance input and does not introduce any distortion upon the line to which it is connected. It furthermore consumes no power.

The Automatic and Complimentary Expander - Compressor—For some types of recordings, it is desirable to have an automatic compressor so as to prevent a continual "riding of the gain" control. As such a compressor is used, it is obviously desirable to be able to play the record back with a complimentary degree of expansion so that the final program will be a close duplicate of the original material. Such an expander-compressor is illustrated in Fig. 10. A switch is provided to cut these features out of the circuit for all normal recording.

The Preamplifier "A" Supply—In order to keep hum well below the threshold of hiss, a special "A" supply (Fig. 11) is incorporated into the amplifier so that all the preamplifier, voltage amplifier, equalizer and electronic mixer tubes have pure D.C. applied to their respective heaters. This feature reduces hum by more than 12 db. and is essential for obtaining humless records.

Hiss is kept at a minimum by careful selection of plate loads and grid resistors so that a maximum gain-to-noise ratio is maintained in each stage. It should be noted that the non-microphonic 1620 triple-grid amplifier is used in the preamplifier stage of the microphone channels.

The Amplifier—Triode Versus Beam Power—Recording technicians can broadly be classified into 2 general groups, one of which believes in triode output tubes only and the other favors the beam power type. In order to satisfy everybody it was decided to make available 2 types of recording amplifiers so that either triode or a beam power unit could be selected! The characteristics of both amplifiers are as close as possible so that one may be substituted in place of the other without making any changes in the rest of the equipment.

COMMON FEATURES OF TRIODE AND BEAM POWER AMPLIFIERS

Both amplifiers are equipped with a VU meter so as to read the actual level being

delivered to the cutter (Figs. 9 and 14). Suitable switches are provided to change the range of the VU readings. An additional pushbutton switch is provided to read the plate current of the output tubes, so that balance could be easily maintained through suitable adjustment within the amplifier. Both amplifiers are equipped with a universal output transformer to match any magnetic or crystal cutter. An auxiliary *thermal relay* is incorporated in the plate supply circuit to avoid the application of plate voltage before correct bias has been attained.

The 2A3 Amplifier—Fixed-bias has been used with these tubes so as to provide the lowest output impedance. A 6F8G acts as a push-pull driver which in turn receives its signal voltage from a 6C8G equalized inverter. (See Fig. 12.)

The Beam-Power Amplifier—This particular unit incorporates a conventional 2-stage direct-coupled push-pull circuit utilizing two 6SJ7s as balanced drivers which in turn is fed by an equalized 6F8G inverter. (See pg. 352, December, 1940, *Radio-Craft*.)

The Monitor Amplifier—A separate monitor amplifier (Fig. 15) is provided for monitoring purposes. *One of the most common errors made by recordists is to use a speaker or headphones across one of the windings of the transformer feeding the cutter.* This invariably introduces additional discrimination because the impedance of the headphones or speaker does not remain constant throughout the frequency range. In addition to this, a true aural picture is not presented to the operator because the cutter impedance changes with frequency so that low frequencies may seem to be lacking in the monitor speaker. For apparent reasons, it is best to use an entirely independent amplifier to drive any type of speaker desired. This, too, is standard practice followed in the design of commercial professional equipment.

MECHANICAL FEATURES

The amplifier is completely housed in a sturdy standard rack, and is designed for desk type operation. Under these conditions, all master controls are easily accessible and may be operated without undue fatigue. Separation of the power supply from the amplifier and preamplifier further decreases the possibilities of induced hum.

The recording system may be extended by adding additional recording amplifiers should it be desired to make 2 or more records at once.

While this particular amplifier has been specifically designed for recording applications (which involve the most stringent requirements) it is naturally admirably adapted for exceptional playback. Its application to P.A. work is, of course, limited by its power output (10 watts) but it is recommended where unusual results are desired.

This article has been prepared from data supplied through the courtesy of Amplifier Company of America.

"A SHORT STORY ON SHORT-WAVE RADIO RECEIVERS"

Under this title, and the subtitle "Things You Never Knew 'Til Now," Hallicrafters presents in a 12-page booklet released last month considerable information of interest to the shortwave listener.

The majority of radio listeners who own receivers capable of shortwave reception will find after reading this interesting booklet that they are able to get better results

YOU'RE LOOKING IN THE WRONG PLACE, DOC. IT HURTS RIGHT HERE!



Here is a definite and direct procedure for servicing . . . information which every Serviceman has needed but which has not been published until now. Clearly written, easily understood, with many diagrams and illustrations, it proves this new system of analysis the natural way to do a good job.

Now you can make a radio talk to you, just as a patient talks to his doctor, "You're looking in the wrong place, Doc—it hurts right here."

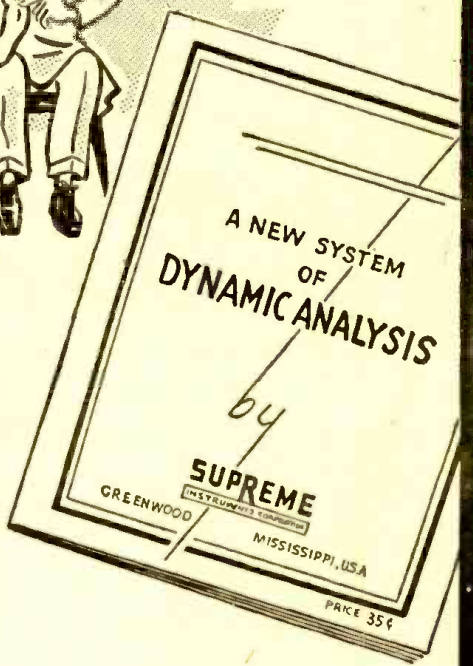

The Supreme Instruments Corporation has been manufacturing good instruments for the Servicemen for the last fourteen years—they are, and, we believe, they will always be your best investment. But here is information YOU NEED—and need badly! The quickest way we can get this to you is in booklet form. . . . It is yours for only 35c to cover cost of printing and mailing.

Send coupon today, or buy from your favorite parts jobber

MAIL YOUR ORDER TODAY

US MAIL

SUPREME INSTRUMENTS CORP., Dept. RC., Greenwood, Miss. Gentlemen: I enclose 35c. Please send me your new book described above.

NAME.....

ADDRESS.....

CITY..... STATE.....

in overseas reception by putting into practice the tips that are given despite the fact that the descriptive material is built around a particular product of one manufacturer. At the same time, this booklet cleverly shows the necessity for certain controls which Hallicrafters considers essential in their newest shortwave receivers.

Meissner I.F. Transformer Replacement Manual.—This 254-page, paper-cover book of course is intended primarily to help sell the company's products. It is a pleasant coincidence therefore that it is also informative reading matter, as compared to merely a catalog, in that it includes a virtual course, in brief, on the design and installation of I.F. coils of all types; detail circuits elucidate the text.

Amazing New "WALSCO" STAPLE DRIVER

for radio men, electricians, or anyone doing stapling. Makes wire and cable installations twice as easy—much neater—saves half the time. Wires can be stapled in corners, behind pipes, into moldings—places never accessible with a hammer and ordinary staples. Drives staples even into walls, brick, mortar, etc. Magazine works automatically and holds strips of staples which come in several colors. Ask your jobber for demonstration and catalogue 41-R of all WALSCO PRODUCTS or write WALTER L. SCHOTT CO. 5264 W. Pico Boulevard, Los Angeles, California

For WIRED MUSIC OPERATORS

Breastplate "Dispatcher" type. Leaves hands free. Handsome dialectic black finish. Arj. fabric neck-band. Choice of single or double headset, high or low impedance. Available total of 12 dif. types and imp. Incl. 7 1/2 ft. flex. cord. Wt. 8 oz. Most attractive, lightweight rugged, practical chest mike yet devised for operators of wired music units. At your dealer or jobber.

UNIVERSAL MICROPHONE CO., LTD. INGLEWOOD, CAL., U. S. A.

Order your copy NOW—the only
P. A. HANDBOOK



ONLY
25
 CENTS
 A COPY

THAT no book has yet been published which covers amplifiers and sound systems (also kindred systems) in one complete, authentic volume is almost unbelievable. Yet, it is a fact, there is no book in print which covers Public Address from A to Z. To bridge this wide-spread gap, RADIO-CRAFT will publish a complete, magnificent volume on Public Address of such magnitude—so complete and authoritative—that every man engaged in radio can have both a theoretical and practical knowledge of the function and operation of sound systems. The editorial pages are so filled with instruction and replete with illustrations that the volume fully justifies its title of 1940 AMPLIFIER HANDBOOK AND PUBLIC ADDRESS GUIDE. This great HANDBOOK on Public Address should be read and studied by those who consistently build, service and sell sound equipment.

A MATCHLESS VOLUME
 As complete as you would expect to find any engineering handbook—this is how the radio or P. A. man finds the AMPLIFIER HANDBOOK AND PUBLIC ADDRESS GUIDE. With essential technical data compiled from an exceptionally large number of sources, the volume covers nearly a hundred different subjects coordinating every conceivable branch or sub-division of Public Address.

THE CONTENTS
 To actually show the scope and magnitude of the AMPLIFIER HANDBOOK AND PUBLIC ADDRESS GUIDE, an analysis of the contents is found at the right, showing the breakdown of the material featured within each particular section. A thorough reading of the contents shows the completeness of this book.

RADCRRAFT PUBLICATIONS • 20 VESEY STREET • NEW YORK, N. Y.

RADCRRAFT PUBLICATIONS, INC. ★ 20 VESEY STREET ★ NEW YORK, N. Y. RC-541
 Gentlemen: Enclosed find my remittance of 25c for which send me POSTPAID, one copy of your NEW—1940 AMPLIFIER HANDBOOK AND PUBLIC ADDRESS GUIDE.

Send me others, for friends, also POSTPAID @ 25c each.

Name Address

City State

Remit by check or money order; register letter
 if you send cash or unused U.S. Postage Stamps.

A Resume of the Contents of the
**AMPLIFIER HANDBOOK
 AND PUBLIC ADDRESS GUIDE**

FOREWORD

INTRODUCTION

Definitions—decibels, frequency, input, output, impedance, etc.

SECTION I—SOURCE

Carbon microphones (single-button and double-button)
 Condenser microphones
 Velocity (ribbon) microphones
 Dynamic microphones
 Crystal microphones (sound-cell types, crystal diaphragm types)
 Cardioid microphones
 Contact microphones
 Phonograph pickups (magnetic types, crystal types)

SECTION II—AMPLIFIERS

Voltage Amplification

Design of resistance-coupled voltage amplifiers
 Commercial voltage amplifier

The Power Stage

Class A amplifiers
 Class AB amplifiers
 Class AB₁ amplifiers
 Class AB₂ amplifiers
 Class B amplifiers
 When to apply class A, AB, and B amplification

Power Supplies

Half-wave rectification
 Full-wave rectification
 Voltage doublers

Filter Circuits

Power supply regulation, etc.

Practical Hints on Amplifier Construction

Microphonism
 Placement of components
 Tone compensation
 Inverse feedback

Remote control methods

SECTION III—DISTRIBUTION

The Loudspeaker

Dynamic speakers
 Speaker performance (frequency response, efficiency)
 High-fidelity speakers
 Speaker Baffles and Housings
 Outdoor speaker installations
 Power cone speakers
 Radial (360° distribution) speaker baffles

SECTION IV—COORDINATION

Input impedance matching
 Matching speakers to P.A. installations
 Phasing speakers

Effect of mismatching speakers to amplifier output

A typical P.A. installation (in a skating rink)

SECTION V—USEFUL PUBLIC ADDRESS DATA AND INFORMATION

Speaker matching technique
 The ABC of Db., VU, Mu, Gm and Sm
 Charts and formulas useful to the practical P.A. sound man
 Handy index to important articles on public address and sound

Order Your Copy NOW—

Clip Coupon and
 Mail Today!

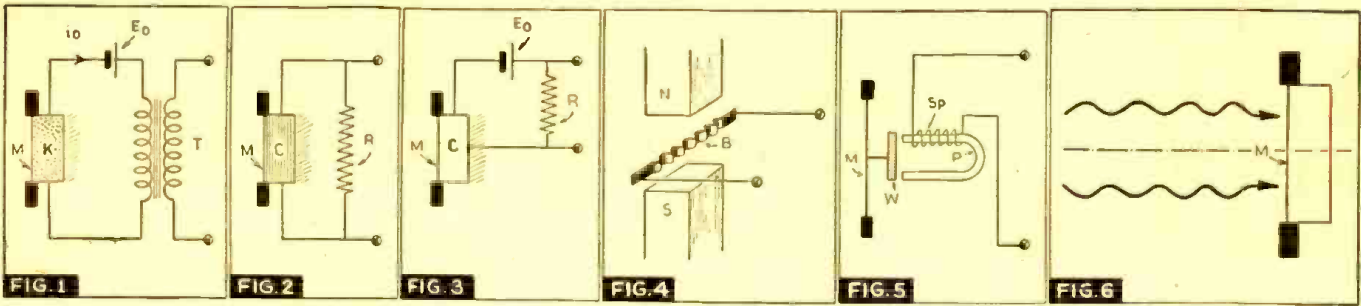

MICROPHONES

—And How They Work

THE name *microphone* was originally used by C. Wheatstone to denote an instrument which served to make very weak sounds audible to the human ear, and which was therefore what we now call a "stethoscope." Now, however, the name microphone is used exclusively for instruments which convert air vibrations into electrical A.C. voltages.

The early development of microphones took place during the years 1876 and 1877. At that time Alexander Graham Bell (1876) was laying the foundations of modern telephony. In his work he used a microphone which worked on the electromagnetic principle. One year later (1877) both Thomas Edison and Berliner were granted patents for a much more sensitive microphone, whose action depended upon the variable resistance of powdered carbon. Since that time the further development of the microphone has gone hand in hand with the development of reproduction and recording of sound.

FROM SOUND TO VOLTAGE

The various kinds of microphones have one feature in common, namely they all first convert the motion of the air particles into motion of a *membrane, ribbon or plate*. This motion leads to the excitation of an electrical A.C. voltage, so that the following sequence is always involved:

motion of air → motion of mem-
brane → E.M.F.

In a sound field the total air pressure can be divided into the normal pressure P of the atmosphere, which is constant, and a varying term pf due to the sound vibrations, the so-called *sound pressure*.

The following requirement is made of a good microphone. The amplitude of the E.M.F. excited by the sound pressure must be directly proportional to the amplitude of the sound pressure for every frequency $\omega/2\pi$ in the frequency range to be reproduced and the proportionality factor must be independent of the frequency. The amplitudes occurring are usually small enough to satisfy the first condition. In this article it will be explained how it is possible to make the proportionality factor independent of the frequency.

(1) In the first place we shall discuss the conversion of the motion of the membrane into an E.M.F., which involves the classification of microphones according to their electrical behaviour.

(2) We shall then deal with the different devices for the conversion of the air vibrations into motion of the membrane. This involves an acoustic classification of microphones.

(3) Finally, the different useful combinations of electrical and acoustic characteristics and several different types of microphones will be described.

ELECTRICAL CLASSIFICATION OF MICROPHONES

E.M.F. is dependent upon the deviation of the membrane.

Carbon Microphone.—In the classic carbon microphones, Fig. 1, a deviation xf of membrane M causes a change in the transition resistance between grains of carbon which are enclosed in a container K . For sufficiently small deviations of the membrane the change in resistance ΔR is proportional to the deviation:

$$\Delta R = Cxf \quad (1)$$

where the proportionality factor C does not depend upon the frequency. The constant E.M.F. E_0 applied to the microphone circuit gives a current $i_0 = E_0/R_0$ when the total resistance of the circuit is R_0 . The small change in resistance ΔR of the microphone is therefore equivalent to an alternating E.M.F. in the microphone circuit:

$$Ef = i_0 \Delta R = C \frac{E_0}{R_0} xf \quad (2)$$

The relation between the E.M.F. Ef and the deviation xf of the membrane is thus independent of the frequency. The A.C. output of the microphone is made available in external circuits by means of coupling transformer T .

Crystal Microphone.—When a *piezoelectric crystal plate* is stretched or compressed, electrical charges occur upon the side surfaces. If such a crystal, C , Fig. 2, is introduced between a rigid wall and a membrane, M , which is set in motion by sound vibrations, an E.M.F. Ef is excited in the crystal which is proportional to the deviation xf of the membrane.

This alternating E.M.F. in turn can be made to excite an alternating current in an electric circuit. The generated A.C. voltage may be taken from across resistor R .

Condenser Microphone.—In the case of the *condenser microphone* the moving membrane forms one of the plates of a con-

denser, Fig. 3. The motion of the membrane, M , causes changes in the capacity of the condenser. When opposite charges have been put on the plates of the condenser over a resistance R by means of an electric battery, the changes in capacity lead to changes in voltage between the 2 plates, which in this case also have the same relation for all frequencies with respect to the deviations of the membrane.

For these 3 types of microphones the E.M.F. generated is proportional to the deviation of the membrane, no matter how high the frequency. For satisfactory functioning of these microphones, therefore, it is only required that this deviation is proportional to the sound pressure for all frequencies. We shall discuss in the following the degree to which this requirement can be satisfied.

E.M.F. depends upon the velocity of the membrane.

Dynamic (so-called Electrodynamic) Microphone.—In the case of an *electrodynamic microphone*, a membrane, ribbon or plate which is set in motion by the air vibrations is either itself electrically conducting or bears a conductor upon it. This conductor is placed in a constant magnetic field, Fig. 4, and included in an electric circuit. Due to the motion of the conductor (B , a vibrating metal ribbon) in the magnetic field the number of lines of force enclosed within the electric circuit changes:

$$N = N_0 + Cxf = N_0 + Cx_0 \cos \omega t \quad (3)$$

where C is a constant and $\omega/2\pi$ the frequency. According to the law of induction, an E.M.F. is hereby excited in this circuit, which is equal to the decrease per unit of time in the number of lines of force enclosed:

$$Ef = - \frac{dN}{dt} = - Cx' = C\omega x_0 \sin \omega t \quad (4)$$

where x' represents the derivative of the deviation with respect to time, i.e., the velocity of the membrane. In the diagram, N is the North pole and S is the South pole of a permanent magnet; the 2 leads from ribbon B deliver the generated A.C. voltage to external equipment.

Magnetic (or so-called Electromagnetic) Microphone.—A small piece of soft iron which completes the magnetic circuit of a permanent magnet is fastened to the vibrating membrane of an electromagnetic microphone, Fig. 5. Due to the motion of the membrane, M, a varying magnetic field occurs which generates an E.M.F. in a stationary electric coil, Sp, surrounding the magnet, P, and forming part of an electrical circuit.

The situation in the case of such an electromagnetic microphone is quite similar to that in the case of an electrodynamic microphone, and in both cases an E.M.F. occurs which is proportional to the velocity, the proportionality factor being independent of the frequency. In order to obtain satisfactory reproduction for all frequencies with microphones which function on the electrodynamic or electromagnetic principle, the ratio between the velocity of the moving system and the sound pressure should therefore be independent of the frequency.

ACOUSTIC CLASSIFICATION OF MICROPHONES

Pressure Microphones.—If one side only of the membrane M of the microphone is exposed to the variable sound pressure *pf*, Fig. 6, one speaks of a pressure microphone.

In this case the force *Kf* which the air vibrations (shown here as a plane sound wave) exert upon the surface *S* of the membrane is equal to the product of this area and the sound pressure:

$$Kf = Spf = Sp_0 \cos \omega t \dots (5)$$

When the mass of the membrane is *m*, the frictional resistance *r* and the stiffness *s*, the equation of motion of this membrane assumes the following form:

$$m\ddot{x} + r\dot{x} + sx = Kf = Sp_0 \cos \omega t \quad (6)$$

where *x'* represents the acceleration.

In such a moving system with one degree of freedom the greatest deviation for a given amplitude of the external force occurs when the frequency of the force is equal to the resonance frequency:

$$\frac{\omega}{2\pi} = \frac{1}{2\pi} \sqrt{\frac{s}{m}} \dots (7)$$

The way in which the amplitude of the vibrating system varies with the frequency differs very much according to whether the frequency in question is sufficiently far above or below the resonance frequency or in its vicinity. In these 3 different frequency regions each of the 3 terms in the left-hand member of equation (6) in turn plays the most important part, so that one may use the following approximations of equation (6) for the 3 regions:

$$\omega > \omega_0: m\ddot{x} = Sp_0 \cos \omega t; \dots (8)$$

$$\omega = \omega_0: r\dot{x} = Sp_0 \cos \omega t; \dots (9)$$

$$\omega < \omega_0: sx = Sp_0 \cos \omega t; \dots (10)$$

In the neighborhood of the resonance frequency, therefore, the sound pressure determines the velocity of the motion of the membrane; for higher and lower frequencies the sound pressure determines the acceleration, viz., the "deviation."

In the case of carbon, piezoelectric (crystal), and condenser microphones, as we have already mentioned, the E.M.F. depends upon the deviation of the membrane. As to the acoustic part of these microphones, care must therefore be taken that the ratio between the deviation and the sound pressure is independent of the frequency, i.e., equation (10) must be valid. These types of microphones must therefore be constructed as pressure microphones, and care must be taken that the resonance frequency for these systems with a single degree of freedom is made so high that the frequency

region to be reproduced falls below it. If the resonance frequency should still lie in the region of the highest tones to be reproduced, a disturbing resonance will occur unless care is taken to make the damping sufficiently severe.

In the frequency region above the resonance frequency the ratio between the acceleration ($x''f = \omega^2 xf$) and the sound pressure is constant, according to equation (8). For the 3 types of microphone mentioned the amplitude of the E.M.F. generated in the microphone circuit varies for high frequencies according to p_0/ω^2 . The sensitivity thus decreases rapidly for high frequencies, as may clearly be seen from the resonance curve given in Fig. 7. In this illustration the resonance curve of a membrane with one degree of freedom is indicated; and, the log. of the deviation *x* is a function of the log. of the frequency.

A microphone working on the electrodynamic or electromagnetic principle will, according to equation (4), reproduce sound satisfactorily if the relation between the velocity of the membrane and the pressure does not depend upon the frequency.

A pressure microphone may therefore only be used in these 2 types in the frequency region for which equation (9) is valid, i.e., in the vicinity of the resonance frequency. By making the mechanical damping large, provision may indeed be made that the frequency region in which the reproduction may be considered satisfactory becomes fairly wide, but the sensitivity then usually becomes too low, so that such a solution remains inadequate.

If for certain reasons it is nevertheless desired to construct a pressure microphone according to the electrodynamic principle, it is advisable (in order to improve the reproduction of tones above and below this resonance frequency), to pass from the system with a single degree of freedom, which has only 1 resonance frequency to a system with several degrees of freedom which give rise to several successive resonance frequencies, Fig. 8. Provision may indeed be made in this way that the sensitivity of the microphone remains practically constant over a wider frequency range, but the reproduction, especially of speech, is of poorer quality due to the maxima which indicate the position of the resonance frequencies in the sensitivity curve of Fig. 8. We shall therefore not consider such microphones further in this article, and consider only microphones with one degree of freedom.

The sound pressure at a point does not depend upon the position of the surface element upon which one wishes to measure its effect. Therefore the action of a pressure microphone will not depend upon the position of the vibrating membrane with respect to the direction of propagation of the sound waves. A pressure microphone is therefore equally sensitive from all directions, so that the polar linear direction diagram of the sensitivity of this microphone is a circle. If the dimensions of the microphone are not small with respect to the wavelength of the sound, the microphone itself distorts the sound so that deviations from this simple picture of the situation occur (*).

Pressure-gradient Microphones.—If both sides of a membrane or a vibrating plate can be reached by the sound waves, Fig. 9, the latter will arrive at the front and rear sides with a certain phase difference. If the sound pressure on the front of the membrane, M, amounts, for instance, to

$$p_1 = p_0 \cos \omega t \dots (11)$$

and if the waves must cover a distance which is *l* cm. longer in order to reach the other side, then for a wavelength λ the

(*) Cf. "Phillips Technical Review," 4, 144, 1939.



FIG. 7

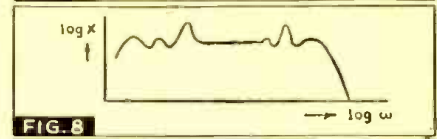

FIG. 8

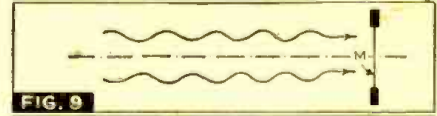

FIG. 9

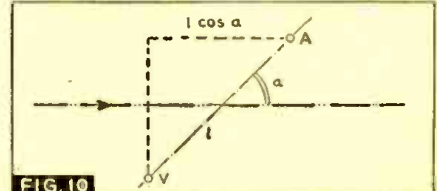

FIG. 10

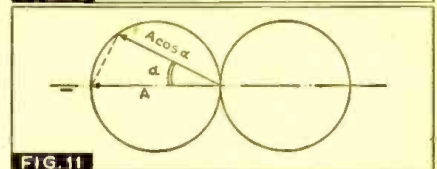

FIG. 11

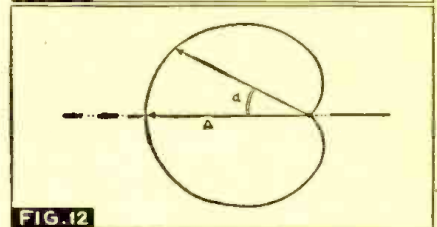

FIG. 12

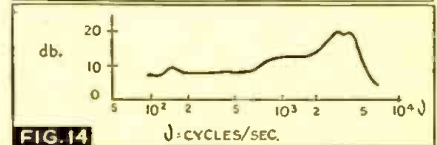

FIG. 14

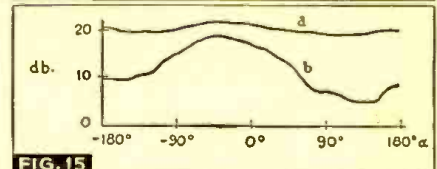

FIG. 15

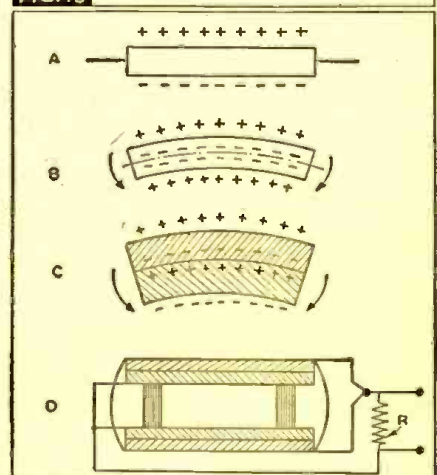

FIG. 17

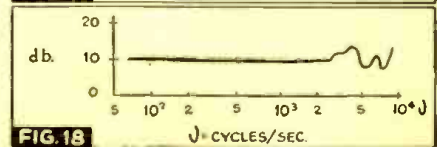

FIG. 18

sound pressure on the rear side of the membrane becomes

$$P_2 = p_0 \cos \omega t - 2\pi \delta/\lambda = p_0 \cos(\omega t - kl) \quad (12)$$

where $k = 2\pi/\lambda = \omega/c$, c representing the velocity of sound. If the membrane has an area S , a force Kf acts upon it which is the product of this surface and the difference in pressure $p_1 - p_2$:

$$Kf = S(p_1 - p_2) = Sp_0[\cos \omega t - \cos(\omega t - kl)] \quad (13)$$

Since this force is proportional to the "pressure gradient," i.e., to the fall in pressure per unit of length, such devices are called *pressure-gradient* microphones.

If the dimensions of the microphones are small compared to the wavelength, i.e., if $l < \lambda$ or $kl \ll 2\pi$, the force becomes:

$$Kf = -Sp_0 kl \sin \omega t \quad (14)$$

At a certain value p_0 of the sound pressure the amplitude of the force acting on the membrane of a pressure-gradient microphone increases proportionally with k , i.e., proportionally with the frequency. The equation of motion for the membrane becomes:

$$m''f + rx'f + sx f = Kf = -Cp_0 \omega \sin \omega t \quad (15)$$

which may be simplified in the following way for the frequency regions indicated:

$$\omega > \omega_0 = \sqrt{\frac{s}{m}} : mx'' = -Cp_0 \omega \sin \omega t; \quad (16)$$

$$\omega = \omega_0 : rx' = -Cp_0 \omega \sin \omega t; \quad (17)$$

$$\omega < \omega_0 : sx f = -Cp_0 \omega \sin \omega t; \quad (18)$$

By integration of (16 and 17) the following expressions are obtained:

$$mx f = Cp_0 \cos \omega t, \quad (16')$$

$$rx f = Cp_0 \cos \omega t, \quad (17')$$

which are valid for $\omega > \omega_0$ and for $\omega = \omega_0$ respectively. From formula (16 and 16') it may be seen that for frequencies sufficiently far above the resonance frequency the ratio of the velocity of the membrane to the sound pressure becomes independent of the frequency. This is exactly what is required of a good electrodynamic (or electromagnetic) microphone, since in that case the ratio between the E.M.F. excited, and the velocity of the membrane, is independent of the frequency. When a pressure-gradient microphone acting on the electrodynamic principle is used, very good reproduction can therefore be obtained for all frequencies above the region of resonance.

If one desired to construct a pressure-gradient microphone on the principle of the carbon, piezoelectric or condenser microphones, it could only be used for frequencies in the neighborhood of the resonance, since only in that region is the deviation proportional to the sound pressure.

The gradient of the sound pressure depends upon the direction in which it is considered. Therefore in the case of a pressure-gradient microphone the induced E.M.F. will depend upon the position of the membrane with respect to the direction of propagation of the sound waves. If in Fig. 10 we indicate the front and rear sides of the membrane by the points V and A , for which points the largest possible difference of path l for the sound exists, then the difference of path when the membrane is turned through an angle a with respect to the direction of propagation of the waves becomes equal to $l \cos a$. In formulas (12) and (14) l must then be replaced by $l \cos a$ so that the induced E.M.F. will also be proportional to $\cos a$. If this E.M.F. is plotted in a polar diagram as a function of the angle a , a directional diagram is obtained which consists of 2 circles touching each other, Fig. 11.

If the membrane is perpendicular to its position of greatest sensitivity, no E.M.F. at all is induced, since the sound waves reach both sides of the membrane simultaneously and no difference in pressure occurs. Microphones with such a direction diagram may very well be used in rooms in which there is much noise and reverberation (2) since this undesired sound in general arrives at the membrane with the same intensity from all direction while the sound to be amplified comes from a definite direction.

Combination of Pressure and Pressure-gradient Microphone—If a pressure and a pressure-gradient microphone are connected electrically in series, a microphone is obtained whose E.M.F. becomes equal to the sum of the E.M.F.s of the microphones. If for instance the E.M.F. E_1 is generated in the pressure microphone and E_2 in the pressure-gradient microphone at its optimum position, then at any given position of the latter (at an angle a) the total E.M.F. is:

$$E = E_1(1 + \cos a) \quad (19)$$

The polar direction diagram then becomes a so-called *cardioid*, Fig. 12. For $a = 0^\circ$ the sensitivity, is greatest, while in the opposite direction ($a = 180^\circ$) the sensitivity would be zero since the pressure and pressure-gradient microphones give exactly equal and opposite E.M.F.s with such orientation. Advantage may be taken of this characteristic when it is desired to reproduce the sound from a given direction while suppressing that from another direction.

TECHNICAL MODELS

After this general discussion we shall now deal briefly with 4 types of manufactured microphones (originally pictured as Figs. 13, 16, 20 and 22, but not reproduced here, since the following discussion is taken to relate to general rather than specific types—*Editor*).

Carbon Microphone.—Carbon microphones may very well be used for the recording of the spoken word. While it is true that with very high sound pressure the magnitude of the contact surfaces between the grains is not proportional to the pressure exerted, so that the sound will be distorted, nevertheless carbon microphones have the advantage that they produce a much larger E.M.F. than other kinds of microphones. A much smaller amplification is therefore needed with a carbon microphone, which makes it peculiarly suitable for simple applications.

The sensitivity of carbon microphones is higher, the larger the grains of carbon which it contains. The quality of the sound, however, diminishes at the same time, since the noise also increases with the size of the grains. Furthermore the carbon packs together somewhat in use, so that the sensitivity decreases with time. This can be prevented by tapping the microphone lightly.

An interesting use of the carbon microphone is the reporter's or *lapel* microphone, which can be worn in the buttonhole. The relative sensitivity expressed as sound energy in db., is shown in Fig. 14 as a function of the frequency, from which it may be seen that the resonance frequency lies at about 3,000 cycles-per-second (or c./sec.); the sensitivity, meanwhile, decreases rapidly with increasing frequency above 5,000 c./sec.

In Fig. 15, the dependence of the relative sensitivity in db. on the direction is plotted in horizontal coordinates for frequencies of 1,000 and 5,000 c./sec., respectively. It may be seen (curve a) that the sensitivity at

(2) Cf.: "Phillips Technical Review," 3, 221, 1938.



1941 EDITION . . .
including
the first collection of
PANEL LAMP NUMBERS
ever attempted!

272 Pages—16,730 Radio Models shown—including data on '41 receivers. Tube replacement information for 100,380 Tubes or Sockets. 586 Trade Names of receivers. Names and Business Addresses of 190 Receiver Manufacturers. **PATENTED, HOLD-TITE, WIRE-O BINDING. The First and Only Compilation of Panel Lamp Numbers.**

Every Radio Serviceman should own one of these Sylvania Tube Complement Books. All the information you'll need—from the oldest set to the latest '41 model—is packed into those 272 pages. And the book is bound by the **WIRE-O** process. It opens flat and there's no danger of it falling apart or of the pages pulling out.

This valuable compilation, the only book of its kind in the field, is one of the 125 silent salesmen Sylvania has created to help you build a sounder, more profitable business. Write today for Sylvania's Tube Complement Book, enclosing 35c in stamps or coins, and for a full list of the sure-fire, tested, dealer aids. Some are free, some cost you just what they cost us—all of them are designed to help you sell more, and make more!

SYLVANIA
Set-Tested Radio Tubes

Also makers of *Hygrade Lamp Bulbs, Hygrade Fluorescent Lamps and Mitalume Fluorescent Light Fixtures*

Learn RADIO SERVICE WORK with these 2 BIG Ghirardi BOOKS

MODERN Radio SERVICING

Learn How with this!

Here's the world's most highly praised course in practical radio service work—all for you in this one handsome 1300-page home-study book. First, a big 420-page section explains all types of servicing test instruments—how they work, how to use them—also, how to build your own. Then, 900 more pages give you a thorough, step-by-step procedure course in trouble-shooting, testing, aligning and repairing all makes of radio sets and other electronic devices by latest scientific "factory methods." Learn radio servicing this quick, easy, economical way. Learn WHAT to do and HOW to do it. Send for your copy today. Use the coupon below!



\$4

RADIO Trouble-Shooter's HANDBOOK

Save Time with this!

Here's real help for servicemen—518 big manual-size pages of valuable, time-saving, factory-checked servicing data right at your finger tips to help you do every servicing job quickly and accurately. It's 52 BIG SECTIONS contain 275 large pages of time-saving "Case Histories" on over 3,300 receive. . . Alignment data for over 15,000 superhets. . . Servicing and installation data for all Auto Radios. . . New Work All Tube, Resistor and Condenser Charts. . . EVERYTHING! Speed up your service work with all the vital servicing data NOW in this one big book.



\$3

518 pp., 134 illus., 8 1/2x11 size.

CLIP OUT! MAIL NOW!

Radio & Tech. Publ. Co., Dept. RC-51
 45 Astor Pl. New York, N. Y.
 Enclosed find payment for:
 MODERN RADIO SERVICING
 RADIO TROUBLE-SHOOTER'S HANDBOOK
 BOTH books at \$8.50 Money-Saving Combination Price
 NAME _____
 ADDRESS _____
 CITY _____ STATE _____
MONEY-BACK IF NOT SATISFIED!

BRAND INVALUABLE! NEW!

ONLY 25¢ copy

1000 FORMULAS & RECIPES

RICHES IN RECIPES TRIED & TESTED PROCESSES PRACTICAL SIMPLIFIED FORMULARY FOR HOME, FACTORY & WORKSHOP

NATIONAL PLANS INSTITUTE

25¢

The greatest, most compact formula book in print. Contains actually 1000 trade secrets, recipes and processes for home, factory and workshop. Check-full of money-making ideas. Has newest tried and tested formulas for making: Glues, Cements and Adhesives; Cleaning Compounds; Paints and Pigments; Wood Stains; Varnishes; Disinfectants and Deodorants; Fire Proofing and Extinguishers; Glassworking; Inks; Insecticides; Laundry Processes; Metal Work; Etching Fluids; Solders; Preserving Essences; Extracts and Flavors; Plastics; Plating Solutions; Polishes; Preservatives; Fireworks; Soaps; Creams; Dyes; Toilet Preparations; Dentifrices and Cosmetics; Hair Preparations; Manicure Preparations; Sun Burn Creams and Lotions; Waterproofing; Waxes and countless others.

A Wonder Book of Useful Knowledge! Worth its weight in gold.

Book is up-to-date. Newest methods—latest discoveries. Remember—1000 clearly described SIMPLIFIED formulas, processes and recipes—MANY NEVER BE FORE DISCLOSED.

68 pages, printed on good paper.

Send for your copy TODAY. Remember. Great fortunes are made from formulas.

25c a copy, sent postpaid anywhere

Send money order, check, unused U.S. stamps or coin.

NATIONAL PLANS INSTITUTE
 246-R Fifth Avenue New York, N. Y.

DUMONT

Precision Built Condensers

at your nearest jobber or write to

DUMONT ELECTRIC CO., INC.
 514-516 BROADWAY NEW YORK, N. Y.

PAPER — MICA — ELECTROLYTIC

1,000 c./sec., varies very little with the direction, so that the ideal pressure microphone is very closely approached. At higher frequencies, however, a much greater dependence on direction appears, as may clearly be seen in Fig. 15b. This is a result of the fact that for frequencies of about 5,000 c./sec., the dimensions of the microphone are no longer small compared with the wavelength.

Crystal Microphone.—In the diagram of Fig. 2 the air vibrations are transmitted by means of a membrane to a piezoelectric crystal. Rochelle salt ($NaKC_2O_6 \cdot 4H_2O$) for example. In crystal microphones constructed in this way care must be taken that the sensitivity for high frequencies does not vary irregularly with the frequency due to resonances in the driving mechanism. The following point must, however, be kept in mind in connection with this type of microphone, even though due care has been taken in this connection.

If a thin crystal plate of Rochelle salt is stretched in the direction of its length (see Fig. 17A) the 2 sides of the plate take on opposite charges, so that when it is used as a membrane (Fig. 17B) and thus bent so that the 2 sides are stretched and compressed respectively, they will then assume the same polarity. If 2 crystal plates are stuck together in such a way that their polarities are opposite (Fig. 17C), a plate is obtained which assumes opposite charges on its 2 free sides upon bending (θ). Two such "bimorphous" crystal plates are mounted together in the manner shown in Fig. 17D. Each of these plates experiences the effect of the sound pressure on the outer side only, so that the result is a *pressure microphone*.

In Figs. 18 and 19 it is shown how the relative sensitivity in db. depends, respectively, upon the frequency and the direction from which the sound strikes the microphone. For frequencies up to 5,000 c./sec., the sensitivity is found to be practically independent of the direction, and above that frequency only slightly dependent on the direction. This is because of the small dimension of the piezoelectric crystal. The resonance frequency lies in the vicinity of 4,000 to 5,000 c./sec., and presents no difficulties. In order to provide that not only the E.M.F. E_f generated, but also the terminals voltage V_f shall depend only slightly upon the frequency, the external resistance R which completes the electrical circuit of the microphone must be made larger than the internal impedance of the microphone. Since the crystal behaves as a capacity C , the terminals' voltage becomes therefore:

$$V_f = \frac{E_f}{\sqrt{1 + 1/\omega^2 C^2 R^2}} \quad (20)$$

This expression is only independent of the frequency when $\omega CR > 1$, i.e., for sufficiently high frequencies, and increases linearly with the frequency when $\omega CR < 1$. If the microphone capacity is, for instance, $C = 0.002$ -mf. and the external resistance $R = 1$ megohm at a frequency of about 80 c./sec., the absolute value of ωCR will be approximately unity, so that $V = 0.72 E$. Above 100 c./sec., the terminals' voltage does not change very much more with the frequency.

In the technical construction of this type of microphone, it is usual to take care that the microphone is well protected against the entry of moisture since the Rochelle salt crystals are not unaffected by water.

Furthermore the microphone may not become too warm. If the Rochelle salt reaches a temperature above 55° C. (131° F.) it loses its water of crystallization which is

responsible for the piezoelectric properties. When the temperature is lowered the water of crystallization does not recombine. The limit of 55° C., is fortunately so high that it is never reached under normal conditions.

Ribbon Microphone.—In the ribbon or velocity microphone, a corrugated aluminum ribbon several microns thick is stretched between the pole pieces of a permanent magnet. The air vibrations exert their pressure on both sides of the ribbon which thus acts as a pressure-gradient microphone. Due to the motion of the ribbon in a magnetic field an E.M.F. is excited in the circuit in which the ribbon is included, so that the microphone is of the electrodynamic type.

According to the foregoing considerations, for a pressure-gradient microphone of the electrodynamic type the reproduction will be practically independent of the frequency when operating above the resonance frequency; formula (16'). In the case of this ribbon microphone the resonance frequency lies at about 50 c./sec., which is sufficiently low to ensure a practically constant sensitivity for the frequencies of speech and music.

It may be seen from Fig. 21 that the relative sensitivity of the ribbon microphone changes only slightly for the frequencies from 100 to 5,000 c./sec., while at 5,000 c./sec., it begins to decrease. This may be explained as follows.

The sensitivity of the microphone is given by the approximation formula (14). If, however, the product $kl = 2\pi r l/c$ becomes of the order of magnitude of 2π , (14) no longer holds; succeeding terms of the series in the precise formula (13) must also be taken into account. From further considerations (θ) it is found that the sensitivity of the microphone will be practically independent of the frequency up to that frequency for which $kl = \pi$, i.e., where the product of k and the width $a = l/\pi$ of the pole piece is about unity. Now $k = 2\pi r/c = 2\pi r/34,000$, so that with a width of the pole pieces of about 1 cm. we may expect that the sensitivity will change little up to a frequency of 5,000 c./sec. For higher frequencies the sensitivity then decreases quite rapidly as may be seen in Fig. 21. If it were desired that the sensitivity should decrease only at a higher frequency, this may be accomplished by making the pole pieces smaller, but under otherwise similar conditions this takes place, according to equation (14) at the cost of the magnitude of the sensitivity.

In Fig. 22 may be seen the manner in which the relative sensitivity of the ribbon microphone at 5,000 c./sec., depends upon the direction from which the sound comes; for lower frequencies the dependence is practically the same. As must be expected in the case of a pressure-gradient microphone, the sensitivity to sound from directions perpendicular to that of greatest sensitivity is practically zero.

Coil (Dynamic) Microphone.—In conclusion we shall describe the so-called dynamic microphone, a second type of pressure-gradient microphone of the electrodynamic type. In order to obtain a larger E.M.F. the conductor which moves in a magnetic field consists of an electric coil in this case. In the diagram of the cross-section, Fig. 24, it is shown how the coil (S_p) is wound upon a paper cap fastened to the membrane. The coil moves in a ring-shaped magnetic field.

Furthermore, the magnetic circuit is not closed over the entire circumference of the ring, but only over parts by means of pieces of magnet steel M. The outer ring and the inner ring which form the North and South

(3) According to the Brush Crystal Co.

(4) J. de Boer, "Physica," 5, 545, 1938.

poles are made of soft iron. If the magnet steel had the form of a complete cylindrical shell, as is the case in the magnetic system of a loudspeaker, the total number of lines of force cut by the vibrating coil, and thus also the E.M.F. excited in the latter, would be larger. In spite of this that form is not chosen, in order to prevent the formation by the magnetic system of a resonating cylindrical space behind the membrane (open organ pipe) which leads to irregularities in the dependence of the sensitivity upon the frequency.

By making the fastening of the membrane very flexible care is taken that the resonance frequency will lie below 100 c./sec. From this frequency, according to Fig. 25, the relative sensitivity is found to depend little upon the frequency, up to about 5,000 c./sec. The magnitude of the sensitivity is such that with a sound pressure of 1 dyne/cm.² and an output impedance of the microphone of 500 ohms, a voltage of 0.9-mV. is obtained.

The manner in which the relative sensitivity depends upon the direction from which the sound comes is shown in Fig. 26. At a frequency of 500 c./sec., the sensitivity for directions perpendicular to that of greatest sensitivity is indeed approximately zero (Fig. 26A) as is to be expected from a pressure-gradient microphone; for higher frequencies the minima are less pronounced (Fig. 26B).

This article is another of the valuable contributions by the Research Laboratory of N. V. Philips' Glowlampworks to the field of radio literature. It is here reprinted from the magazine "Philips Technical Review" by special permission to Radio-Craft.

Stands Out BECAUSE IT STANDS UP!

Here's the instrument that has been leading the field for five years . . . and still is "tops" for radio servicing. That's because it measures in fundamental quantities . . . *no trick circuits or gadgets to cause early obsolescence* . . . and because it is designed and built to high WESTON standards. It is an instrument that, with usual instrument care, will remain serviceable indefinitely. Be sure to get full information on this complete, inexpensive test instrument. Write for bulletin describing Model 772 and other WESTON instruments for radio and television servicing. Weston Electrical Instrument Corp., 599 Frelinghuysen Avenue, Newark, N. J.

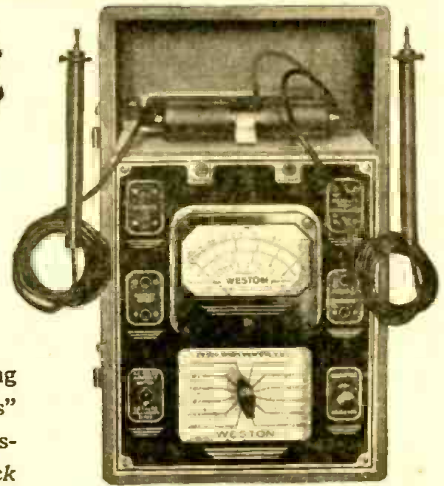

WESTON Model 772 Super-Sensitive Analyzer

RANGES

Volts... DC—2.5/10/50/250/1000...
sensitivity 20,000 ohms per volt
AC—2.5/10/250/1000... sensitivity
1000 ohms per volt.
Current... DC—.1/1/10/50/250 milli-
amperes 1/10 amperes
Ohms... 0-3000; 0-30,000 ohms . . .
0-3 megohms; 0-30 megohms
Decibels... -14 +2/-2 +14/+12 +
28/+26 +42/+38 +54

WESTON Radio Instruments

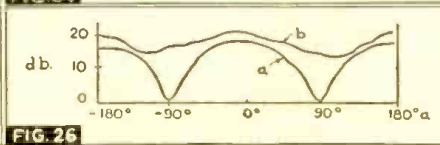
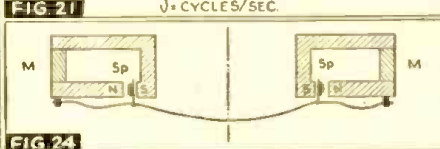
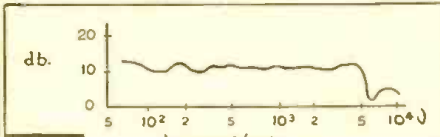
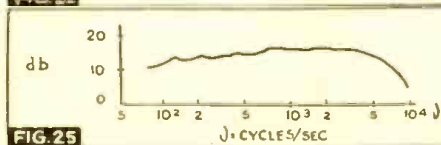
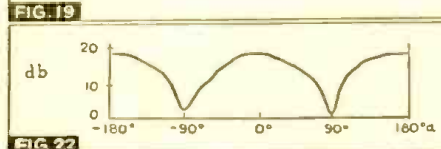
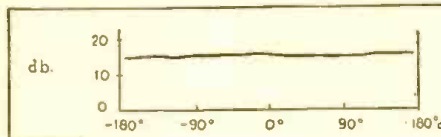

UNIQUE CALL LETTERS

WHEN WOR's new commercial F.M. station—a construction permit for which has been granted by the F.C.C.—begins operation, the station will have the new type call letters recently inaugurated by the F.C.C.

If the assignment of these letters runs according to indicated pattern the station will bear the letters—W71NY. The "71" will indicate the station's location on the new F.M. radio dial, which corresponds with the frequency used by the station of 47,100 kilocycles (47.1 mc.).

The new method of identifying all F.M. stations recently announced by the F.C.C. provides that the 2nd and 3rd numerals of the station's frequency be used, since all F.M. stations will be alike in having a frequency beginning with 4 and ending with 00. The letters "NY" will identify the loca-

tion of the station as being in the Metropolitan area.

The first letter, W, indicates a location east of the Mississippi River. This is the only similarity to the method of assigning call letters to the regular, or longwave, broadcasting stations, although some exceptions exist among the regular stations.

Pending the construction of the new station, WOR will continue to operate its experimental F.M. transmitter, W2XOR, from 444 Madison Avenue, New York City. The new station will be at the same address.

NEWS SHORT

The cow juice output dropped, last month, when someone stole a radio set from the dairy barn of a Chillicothe, Mo., farmer; and went right back up, when a new set was installed!

FIX ANY RADIO Amazing New Invention

Simplified
Radio
Servicing
by
Comparison
Method

Repair radios in minutes instead of hours. Revolutionary, different Comparison technique. Permits you to do expert work immediately. Most repairs can be made without test equipment. Simple, point-to-point, circuit suggestions locate the fault instantly. Plan copyrighted. Covers every radio set—new and old.

Complete
\$1
Training

In Manual form, 8 1/2 x 11 in., 112 pages. Over 1,000 practical service hints, 18 large trouble-shooting blue-prints, 14 different tests using a 5c resistor. Invented by M. N. Beltman, noted engineer and radio teacher. Write today. SUPREME PUBLICATIONS, Room 857 3727 West 13th Street Chicago, Illinois



DIRECT-COUPLED
AMPLIFIERS
ENGINEERED BY
A. C. SHANEY

Write For Complete Details
AMPLIFIER COMPANY of AMERICA
17 W. 20TH STREET NEW YORK, N. Y.

SOLAR RED-CAPS
Smaller Diameter Dry Electrolytics
SPEED Servicing
Write for Catalog
SOLAR MFG. CORP. Bayonne, New Jersey

THE FINEST RADIO BOOK FREE WE EVER OFFERED :- the 1940-41 Radio-Television Reference Annual With \$1.00 subscription to RADIO - CRAFT

WITH our compliments, we want to send a copy of the 1940 RADIO-TELEVISION REFERENCE ANNUAL to you FREE, if you will simply take advantage of RADIO-CRAFT magazine's special subscription offer NOW. This offer is being made for a limited time only.

The 1940 RADIO-TELEVISION REFERENCE ANNUAL has 68 pages, large size 8½ x 11½, with over 170 illustrations. The contents of this book has never appeared before in handy book form. Its pages cover practically every branch of radio sound, public address, servicing, television, construction articles for advanced radio men and technicians, time and money-saving kinks, wrinkles, useful circuit information, "ham" transmitters and receivers, and a host of other data.

The Annuals have always been regarded as a standard reference work for every practical branch of radio operation and service. This 1940 edition ably sustains this reputation. Every radio man wants a copy of this valuable book. Just as this book will be of unquestionable value to you, so, too, will every monthly issue of RADIO-CRAFT. This magazine brings you big value every month. It keeps you intelligently informed about new developments in radio and television. You want the news, want it fully but concisely, want it first—that is why you should read RADIO-CRAFT regularly.

This very special offer is made for just one purpose—we want you as a regular subscriber. The Annual, whose contents appears at the right, is not sold, but a copy is FREE to you if you subscribe now.

**SAME SIZE AS
RADIO-CRAFT**



THIS COUPON BRINGS YOU THE ANNUAL

RADIO-CRAFT • 20 VESEY STREET • NEW YORK, N. Y.

Gentlemen: Enclosed you will find One Dollar for which enter my subscription to RADIO-CRAFT Magazine for Eight Months. Send me ABSOLUTELY FREE and POSTPAID, my copy of 1940 RADIO-TELEVISION REFERENCE ANNUAL.

This is a new order Extend My Present Subscription

NAME ADDRESS

CITY STATE

DON'T DELAY — MAIL TODAY! RC-541

**Read the summary of contents
in this FREE BOOK!**

THE 1940 RADIO-TELEVISION REFERENCE ANNUAL contains a collection of the best and most important articles. Covering as they do nearly every branch of radio, they form a handy reference works. In addition, many time and labor-saving kinks, circuits and wrinkles, tried and tested by practicing Servicemen, experimenters and radio fans have been included. This book cannot be bought anywhere at any price. Yet it is yours by merely subscribing. Use the convenient coupon below.

BEGINNER'S SIMPLE INEXPENSIVE CONSTRUCTION ARTICLES

Beginner's Breadboard Special - a 1-Tube High-Gain All-Wave Receiver—Wiring Pointers for Radio Beginners—A Watch Charm Size 1-Tube Set—Beginner's Simple Volt-Milliammeter—Making a 1-Tube Broadcast Loop Receiver—A.C.-D.C. Power Supply for Battery Portables—A 1-Tube Short-Waver with Band Coil Switching.

MORE ADVANCED SET CONSTRUCTION

The "High-Seas 4" Broadcast Lamp Radio—How to Build a 6-Tube 1.4-Volt Short-Wave Superhet for the "Ham" or Short-Wave Fan—Build the "Lunch Box 5" Super Set - a Broadcast Battery Portable—How to Build a Plug-Together 8 Tube Broadcast Set—The "5-in-1" All-Wave Radio for A.C. Operation—An Easily-Built 3-Tube Midget Broadcast Superheterodyne Receiver.

THE SERVICEMEN'S SECTION

Base Tone Control—Simplified Variable Selectivity—Practical Servicing Pointers—Servicing Unrotated A.C.-D.C. Receivers—Killing the "Intermittent" Bug—A Service Shop A.C. to D.C. Power Supply—Sideline Money for Servicemen—Adding A.V.C. to any Screen-Grid T.B.F. Receiver—Iron Particles in Speaker Air Gap.

TEST INSTRUMENTS

A Useful Neon Lamp Tester—An Inexpensive Output Meter—Making Milliammeter Multipliers—Home-Made Frequency Modulator—The Busy Servicemen's V.T. Volt-Meter.

PUBLIC ADDRESS AND AMPLIFIERS

Build this Combination A.C.-D.C. Radio and Inter-Communicator—Speaker Placement in P.A. Work—The Design and Construction of an Inexpensive All-Push-Pull 10-Watt Amplifier—Obscure Sources of Hum in High-Gain Amplifiers—How to Build a High-Fidelity 5-Watt Versatile Amplifier.

"HAM" SECTION

Ultra-High Frequency Antennas—The Beginner's Low-Cost Xmitter—Modulator Meter—Phone Monitor—The Beginner's "Ham" Receiver—2½ Meter Acorn Transceiver.

TELEVISION

How to Build a 441 Line T.R.F. Television Receiver—Useful Notes on Television Antennas.

MISCELLANEOUS

Simple Photo-Cell Relay Set Up—Making a Burglar Alarm—How to Build A.C.-D.C. Capacity Relay—How to Make a Modern Radio Treasure Locator.

USEFUL KINKS, CIRCUITS AND WRINKLES

Making a Flexible Coupler—Two-Timing Chime—A Simple Portable Aerial—An Improvised Non-Slip Screw-Driver. NOTE: The book contains numerous other useful Kinks, Circuits and Wrinkles, not listed here.

(approximately)

45 ARTICLES

(approximately)

170 ILLUSTRATIONS

68 BIG PAGES

**RADIO-CRAFT
20 VESEY STREET
NEW YORK, N. Y.**

RADIO-CRAFT for MAY, 1941

SOUND ENGINEERING

Free Design and Advisory Service
For Radio-Craft Subscribers

Conducted by A. C. SHANEY

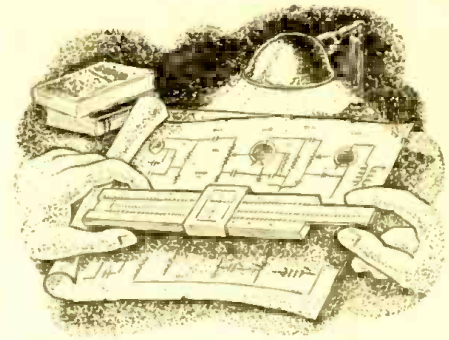

This department is being conducted for the benefit of RADIO-CRAFT subscribers. All design, engineering, or theoretical questions relative to P.A. installations, sound equipment, audio amplifier design, etc., will be answered in this section. (Note: when questions refer to circuit diagrams published in past issues of technical literature, the original, or a copy of the circuit should be supplied in order to facilitate reply.)

No. 17

LOW-FREQUENCY ATTENUATION FOR RECORDERS

The Question . . .

I have built an amplifier for radio and recording but I have some difficulty with too much bass response. The tube lineup I have is a triode 6J7 to a triode 6F6 to a pair of 6F6 triodes to a pair of 6L6s. The last two stages are transformer-coupled but the 6J7 and 6F6 are resistance-capacity coupled, using a 0.05-mf. coupling condenser while the 6F6 to pair of 6F6s is transformer-coupled; the primary is not connected directly to the driver tube, but through a 0.25-mf. condenser.

I have read and also been told that these coupling condensers will control the frequencies that are passed, but I do not understand how this is accomplished or what the technical reason is. Could you tell me how I may cut these low frequencies so they will help me in getting a better recording? The radio receiver sounds all right, but when it comes to recording, it is not right. As you perhaps know in recording, the amplifier can be in the higher register but still make a "fidelity" recording, as the recorder will build up the low frequencies (this I have been told). Could you explain a few of these bugs to me?

Well, to complete the story, the 6L6s

have inverse feedback and they drive a 12-inch speaker in a reflex cabinet. Sounds like a mess, but it works beautifully, except for the recording. I have a preference for low "bassy" sound, so I did not mind the radio set playing the way it did, as it was perfect as far as I could see, and others thought so too, but it is too bassy for recording. Thank you for any aid you may be able to give me.

AL RUOFF,
Maywood, Ill.

The Answer . . .

As you did not include a circuit diagram with your question, I presume that the basic coupling circuits of the 6J7 triode to the 6F6 triode, and its associated input transformer is similar to the assumed diagram indicated in Fig. 1.

You can attenuate the low frequencies by decreasing the 0.25-mf. coupling condenser from the plate of the 6F6 into the push-pull input transformer, or by decreasing the 0.05-mf. coupling condenser between the 6J7 triode plate and the 6F6 grid.

To understand how decreasing this coupling condenser will decrease the low-frequency response, it is necessary to redraw the coupling circuit between the 6J7 and 6F6 of Fig. 1 into the circuit indicated in Fig. 2. The coupling condenser X_c has

been intentionally drawn as a resistor, which is what it actually is insofar as its A.C. function is concerned.

In the analytical diagram of Fig. 2, μE_g represents the input voltage to the control-grid of the 6J7 multiplied by its amplification factor. Item r_p represents the plate resistance of the tube; r_l , its load resistance; X_c , the coupling condenser, and r_g , the control-grid resistor in the succeeding 6F6 grid circuit.

The voltage E_{g2} , which appears at the control-grid of the 6F6, will depend upon the value of X_c , assuming that r_g , r_p and r_l remain constant, which is the usual condition in an ordinary amplifier. If X_c is made large, it is obvious that only a small portion of the voltage that appears across r_l will appear as E_{g2} . On the other hand, if X_c is made small, then most of the voltage which appears across r_l will appear at E_{g2} .

Now, if you will imagine that a condenser is a resistor, which has the property of varying its value inversely proportional to frequency, you will have a pretty good picture of what actually happens in this circuit. For example, if you were to calculate the capacitive reactance of a 1-mf. condenser at 100 cycles, you would find it to be approximately 1,600 ohms. A 0.5-mf. will be approximately 3,200 ohms. A 0.05-mf. will be approximately 32,000 ohms. At 50 cycles, however, a 0.05-mf. is 64,000 ohms, 0.01-mf. condenser at 50 cycles is approximately 320,000 ohms, and a 0.001-mf. unit is 3.2 megohms.

If r_l (in Fig. 2) is small compared to $r_g + X_c$ at any frequency, then the voltage

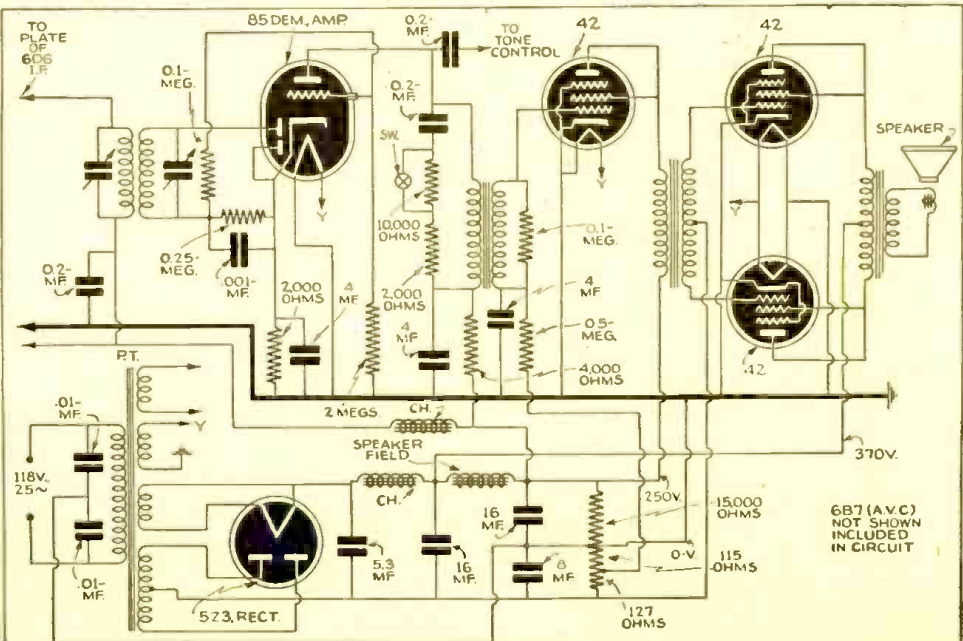
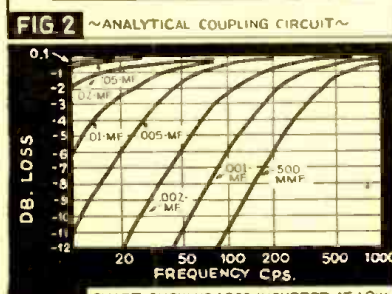
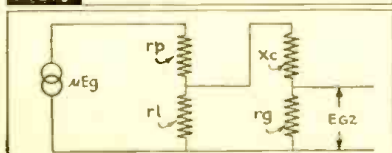
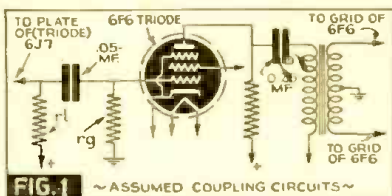

PREFERRED

BY
U. S. GOVERNMENT
IN THE NATIONAL
DEFENSE
PROGRAM



100%
STORM-
PROOF

SUPER-
POWER,
COMPACT

DR-72
SIX FOOT
TRUMPET

\$29.40
NET

★ ATLAS SOUND

Equipment is preferred by the U. S. Navy, Army, and Coast Guard for all conceivable applications under the severest operating conditions. Such recognition is true evidence of high quality standards. ★ ATLAS SOUND PREFERRED by SOUND ENGINEERS for the greatest selection of speakers, projectors, baffles, microphone stands, and connectors for all p. a. purposes. ★ ATLAS SOUND PREFERRED by RADIO JOBBERS for a consistent record of quality and service. Jobbers recommend Atlas Sound with assurance of dependability and satisfaction. ★ FREE CATALOG F-40 describes 101 speakers and accessories for every p. a. use. Send for your copy today.

ATLAS SOUND CORPORATION
1446 39th STREET BROOKLYN, N. Y.



WOODSTOCK TYPEWRITERS

ELECTRIC LANTERNS

\$3.19



← No. 400. Price \$3.19. 1500 foot Power Beam. Two reflectors. Steel construction. Finished ebony baked enamel. Takes standard 6 v. Battery.

\$1.48



→ No. 500. Price \$1.48. 1000 foot Power Beam. Size: Height 7". Steel construction. Finished baked lacquer. Takes standard 6 v. Railroad type Battery.

\$2.69

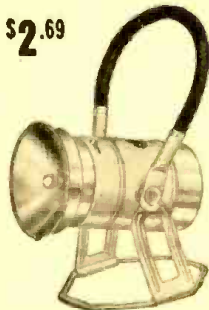

← No. 600. Price \$2.69. 1500 foot Power Beam. Steel drawn construction. Unbreakable plastic lens. Takes standard 6 v. Battery.

Shipping weight for any of the above Models 3 lbs. Furnished without Batteries.

All merchandise in original packages—never used. Money-back guarantee.

All Shipments will be forwarded by Express Collect if not sufficient postage included.

WELLWORTH TRADING CO.
1915 So. State St. Dept. RC-541 Chicago, Ill.

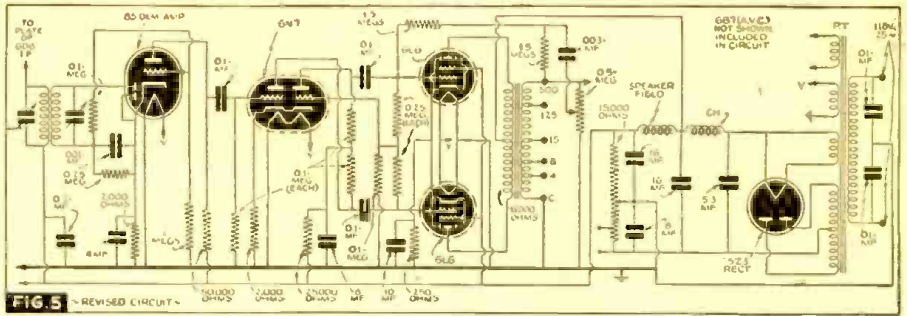

which appears as E_{g2} will be equal to r_g

$$\frac{X_c + r_g}{r_g}$$

If we designate X_{c1} as a smaller condenser, which we intend to substitute in place of X_c , then the ratio of voltage which appears at E_{g2} using first X_c and then X_{c1} is equal to

$$\frac{r_g}{X_c + r_g}$$

$$\frac{r_g}{X_{c1} + r_g}$$

which may be simplified to

$$\frac{X_c + r_g}{X_{c1} + r_g}$$

As this is a voltage ratio, it may be expressed as loss in db. by multiplying its log by 20 so that our final formula becomes

$$\text{loss in db.} = 20 \log \frac{X_{c1} + r_g}{R_c + r_g}$$

In actuality, the impedance of r_g and X_{c1} is equal to the square root of the sum of their squares, so that the correct technical formula for the loss in db. when condensers are substituted, becomes

$$\text{loss in db.} = 20 \log \frac{\sqrt{X_{c1}^2 + r_g^2}}{\sqrt{X_c^2 + r_g^2}}$$

To simplify the application of this formula, the chart of Fig. 3 is given. A casual observation will disclose that a 10.4 db. drop will be encountered at 50 cycles when the 0.05-mf. condenser is changed to a value of 0.001-mf. This chart has been prepared by assuming r_g equals 1 megohm. It is also assumed that the plate resistor and load resistor, in parallel, of the preceding stage are negligibly small in comparison with r_g . When this does not hold, the attenuation is less than that shown by the curves. The exact amount of attenuation can be calculated, but it is felt that this extreme accuracy is not required for purposes of this discussion.

From your letter, I presume that you are positive that you have excessive bass. I can therefore safely guess that you are using a magnetic cutter. Magnetic cutters have a tendency to build up low frequencies, because the amplitude of the cutting stylus depends upon the amount of current passing through the cutting head coil. As the cutter impedance decreases at low frequencies (this is characteristic in all inductive devices), higher currents will pass through the head, which in turn will provide greater amplitude excursions. This will naturally cause excessive bass. This phenomenon is also characteristic of constant-velocity recordings.

In commercial work low frequencies are attenuated in order to avoid this condition. It can easily be done by following the method suggested previously. There is a

possibility, however, that you are losing high frequencies in your input push-pull and coupling transformers. This high-frequency loss will subjectively produce the same results as excessive bass boost. The way to check for excessive bass or excessive high-frequency attenuation is to make a response run and compare the output with a mid-frequency of 600 cycles.

For a more detailed discussion on this phase of the subject, please refer to "Balanced Audio Spectrums," which appeared in the Sept. 1940 issue of *Radio-Craft*, pg. 164.

IMPROVEMENT OF RADIO RECEIVER AMPLIFIER

The Question . . .

In the March 1940 copy of *Radio-Craft*, pg. 531, you published a circuit including a simple self-balancing phase inverter working into a pair of 6L6s.

(1) Is this circuit applicable and suitable for replacing the audio end of the Stromberg-Carlson model 68 shown in the accompanying diagram, Fig. 4, for home use at moderate to high output?

(2) What can I expect in the way of frequency response from control-grid of 85 to secondary of output transformer?

(3) What is the probable output?

(4) Can you suggest any further changes, or additions in this circuit?

The lineup of the present circuit is:—

6D6 R.F.	6B7 A.V.C.	6D6 I.F.
76 Osc.	42 1st Audio	85 Dem & 1st Audio
6A7 Mod.	42 P.-P. Output	5Z3 Rectifier

(5) Is there a simple explanation and cure for the type of distortion, accompanied by steady whistle or hiss, which is sometimes stopped by grounding the speaker frame, or bypassing the grid-return of the output stage with up to 8 mf. (oscillation?)

CHARLES D. HESS, M.D.,
Hamilton, Canada

The Answer . . .

(1) The audio circuit (Fig. 1, March 1940 *Radio-Craft*) will considerably improve the present radio receiver audio amplifier.

(2) The frequency response of the amplifier circuit should be substantially flat between 30 and 15,000 cycles. The 85 demodulator will probably limit the high-frequency response to approximately 8,000 or 9,000 cycles.

(3) The 6L6 amplifier will produce approximately 25 watts with less than 5% distortion.

(4) Your present amplifier can be improved by changing the type 42 push-pull output tubes to 6L6s and removing all inter-stage coupling transformers.

(5) The steady whistle or hiss that you mention is undoubtedly a high-frequency oscillation, which is caused by high-frequency feedback (regeneration), and is usually stopped by grounding the core of

the output transformer, or one side of the secondary, or both.

If the high potential plate or screen-grid leads of the power output tubes run close to any of the input circuits, they should be shielded.

DETECTIVE AMPLIFIER

The Question . . .

As a subscriber to *Radio-Craft*, I am presenting my problem: to build an amplifier for detective work, for which I have frequent calls. The amplifier should be lightweight and portable (frequently have to carry entire equipment by hand 4 or 5 blocks after leaving car).

10 watts output for operating loudspeaker and recording.

Gain 130 db., or better, so as to pick up weakest voices.

Mike should have high output and be sensitive to weakest sounds.

What type of microphone shall I use? Microphone, of course should be 200 ohms, so as to run long lines.

Dual frequency control, without cutting gain, so as to get different voices to best advantage.

Greatest amount of A.V.C. without distortion (and without increasing size and weight of amplifier too much), so as to eliminate blasting and at same time, pick up faint voices.

Hum and tube noise at minimum (way down) so voices can be understood, as in detective work it is frequently required to make a typewritten transcript which means that every word spoken must be understood without chance of error or guessing what was said.

Appreciate very much if you can give us circuit diagram of amplifier to meet above requirements.

C. I. SCHUPP,
Redondo Beach, Calif.

The Answer . . .

Your question is typical of many received which we can not intelligently answer because of the indeterminate specifications given. For example, you state the amplifier should be lightweight and portable. It is virtually impossible to design an amplifier in accordance with your requirements, and have it lightweight in the true sense of the word. I wonder whether you realize how much gain 130 db. actually is. In the present state of the art, it is extremely costly to design a really quiet amplifier providing

SPRAGUE and NATIONAL DEFENSE

National defense needs come first!

Sprague is putting them first—fully and wholeheartedly. One of our two big factories in North Adams, Mass., is now devoted almost solely to defense work.

Meanwhile, our other factory is turning out more Sprague Condensers, Koolohm Resistors and Test Equipment for the Radio trade than ever before. Deliveries are prompt. Full Sprague quality is being rigidly maintained. Development work continues as in the past.

Thus, thanks to Sprague's size and unique facilities, we are able to put defense first—and still not neglect our longtime friends of the Radio profession.

Sprague Products Company

North Adams, Mass.



a usable gain of 130 db. throughout the entire audio spectrum.

To introduce an A.V.C. circuit, which would provide a usable control range, would add considerably to both the cost and complexity of the circuit. To design an amplifier in which hum and tube noise is "way down", you would have to define "how low is down".

I hope you don't mind this constructive criticism, for if it helps other readers state their problems more definitely, then it will have accomplished its intended purpose.

Technical Review of Catalogs

Ohmite Catalog No. 40.—Contains not only the usual illustrations and descriptions of company products, but also contains such useful information as how to select a resistor, characteristics of resistors at high frequencies, how a tapered winding functions, selecting proportional and tapered rheostats, circuits and data on the control of motor speed, selection of rheostats for lamp dimming and for remote indicators, selection of generator power controls, Ohm's Law in chart form and application data on Ohm's Law for A.C. and D.C., definitions of resistor terms, parallel resistor chart, and useful reference data as for example, wire tables, etc. Write on company letterhead.

Thorndarson Transmitter Guide, No. 344-E.—This catalog includes circuits, photos and construction data on fixed and mobile phone and code transmitters, with outputs from 12 to 1,000 watts at various wavelengths. Of particular interest are the articles on Class B Output Calculations, Driver Transformer Ratios, Matching Class C Loads of Modulators, Matching Universal Transformers,

and Matched Power Supplies.

Sears, Roebuck & Co., "Silvertone Sound Systems" Catalog.—Contains a useful technical page on the selection and use of microphones, amplifiers, and loudspeakers for various services.

Birnbach General Catalog No. 41.—Contains a useful article on determining the lengths of the elements of ultra-high-frequency antennas for transmission and reception.

General Catalog No. 41.—Just issued by Atlas Press Co., this publication is of exceptional interest to shop men who own power tools. In addition to catalog information on the regular line of Atlas lathes, Catalog No. 41 also illustrates and concisely describes an exceptionally wide range of power equipment including lathe attachments and accessories, milling machines, shapers, drill presses, vises, and grinders, and arbor, hydraulic and general presses.

Of particular interest to many radio shop owners and garage radio-mechanics, are the descriptions of *armature servicing outfits.*

These Easy-to-Sell—Giant-Size AIR CIRCULATOR FANS

WILL NET YOU \$15 to \$35 PROFIT ON EACH SALE



8-FT. FLOOR MODEL \$16.94 LIST \$60

Make Big Money—sell these flashy-chrome, giant-size Circulator Fans to the stores, restaurants, beauty parlors, taverns, offices and factories in your town.

Cheapest form of summer cooling. One fan cools a 75-ft. store and lets people work better, shop more leisurely, and rest or play in comfort. No sales resistance!

We sell you these fans at rock-bottom prices. \$12.69 buys the \$50.00, 20" chrome-blade, G-E powered Counter Model; for \$4.25 additional you get the \$60.00, 8-ft. Floor Model. Prices are net and F.O.B. Chicago, shipped K.D.

Fans come with cadmium plated guards, chrome columns and bases, and 12-ft. cord with on-off switch. Assembled in 5 minutes. 300% profit per fan.

Get started now and you can gross \$2,350 profit like Wilson; \$1,020 like Whitlow; \$3,000 like Borell. Order your demonstration fan now and a copy of our wholesale catalog today—it's jam-packed with electrical merchandise at bargain prices. Sent to DEALERS and RESALE MOTOR MERCHANTS ONLY.

1/4 H.P. SPLIT PHASE MOTOR BARGAIN

Our lucky purchase is your gain. Product of a famous maker. Service many uses. 1/4 H.P. 110 V. 60 C. A.C. 1750 R.P.M. 1 1/2" shaft. 3 1/2" base to shaft center. 3 1/2" x 4 1/2" bolt holes. Buy now and save over 25%. No. 11397 ca. \$4.99 net f.o.b. Chicago.



W. W. Grainger, Inc.
821 W. Congress St.
Chicago, Ill.

- Send WHOLESALE CATALOG
- Ship 20" Counter Fan @ \$12.69 net
- Ship 20" Floor Fan @ \$16.94 net
- Ship 1/4 H.P. Motor @ \$4.99 net

Name
Address
(Paste Coupon on 1c Post Card and Mail Today)

RCA VICTOR MODEL VHR-307 HOME RECORDING - PHONO - RADIO COMBINATION
(Chassis No. RC-555)

12-Tube Superhet.; Automatic Volume Control; "Magic Eye" Indicator; Microphone Preamplifier; Power Output 18 watts; 15-inch Electrodynamic Speaker; 105-125 volts, 60-cycle operation; Crystal Pickup; Crystal Cutting Head. Ranges: 540-1,600 kc.; 5.8-18 mc.; and, a Spread Band of 9.34-9.86 mc. (See Data Sheet 307 for additional information.)

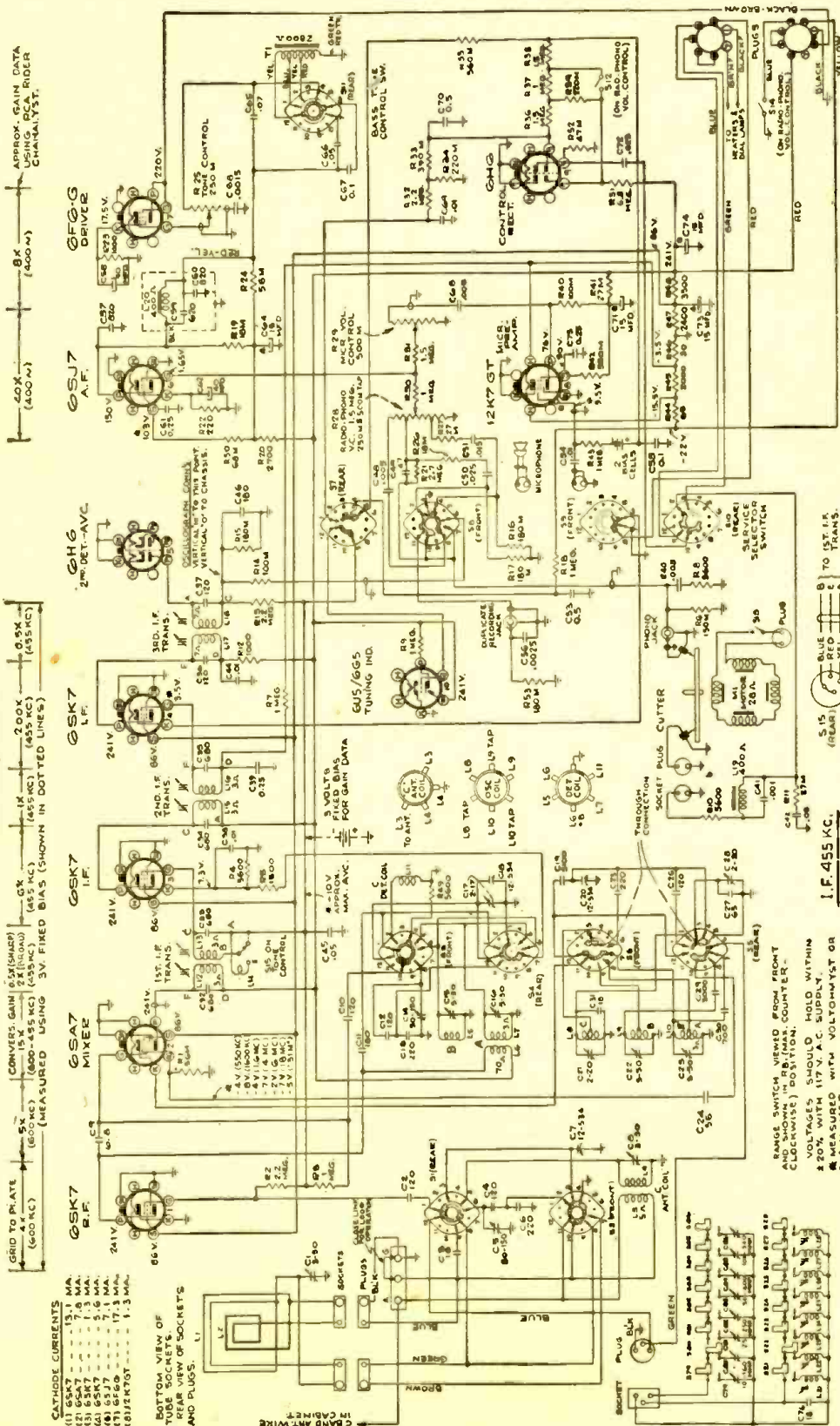

Schematic diagram of RCA Victor Model VHR-307, less power supply and push-pull output power stage. (See Data Sheet 307 for latter.)

PUSHBUTTON ADJUSTMENTS

The pushbuttons connect to separate magnetite-core oscillator coils and separate loop circuit trimmers which must be adjusted for the desired stations. Use an insulated screwdriver or alignment tool such as RCA Stock No. 31031. Allow about 5 minutes warm-up period before making adjustments.

The procedure is as follows:

- (1) Make a list of the desired stations, arranged in order from low to high frequencies.
- (2) Turn the range switch to the broadcast position and manually tune-in the first station on the list.
- (3) Turn range switch to pushbutton position and depress the left-hand button.
- (4) Adjust core rod No. 1 to receive the first station. To secure the best adjustment, rotate the loop for least pick-up, and adjust core rod No. 1 for peak output.
- (5) Adjust trimmer screw No. 1 for peak output on the first station.
- (6) Proceed in the same manner to adjust for the remaining stations.
- (7) Repeat adjustments for best results.

On the 880 to 1,550 kc. pushbuttons, the higher frequency stations may be received with

ALIGNMENT PROCEDURE

Cathode-Ray Alignment is the preferable method. Connections for the oscilloscope are shown in the schematic diagram.

Output Meter Alignment—If this method is used, connect the meter across the voice coil, and turn the receiver volume control to maximum.

Test-Oscillator—For all alignment operations, connect the "low" side of the test-oscillator to the receiver chassis, and keep the output as low as possible to avoid A.V.C. action.

(Continued on Data Sheet No. 307)

Radio Service Data Sheet

RCA VICTOR MODEL VHR-307 HOME RECORDING - PHONO - RADIO COMBINATION (Chassis No. RC-555)

12-Tube Superhet.; Automatic Volume Control; "Magic Eye" Indicator; Microphone Preamplifier; Power Output 18 watts; 15-inch Electrodynamic Speaker; 105-125 volts, 60-cycle operation; Crystal Pickup; Crystal Cutting Head. Ranges: 540-1,600 kc.; 5.8-18 mc., and, a Spread Band of 9.34-9.86 mc. (See Data Sheet 306 for additional information, and main diagram.)

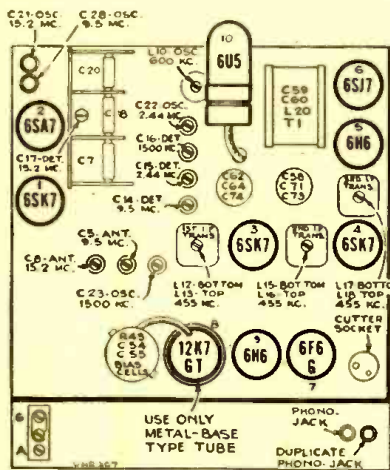

Left, chassis view showing locations of tubes, main components, and trimmers. Right, schematic diagram of the power supply and output stage. (Continued from Data Sheet 306)

Steps	Connect the high side of the test-osc. to	Tune test-osc. to—	Turn Radio dial to—	Adjust the following for maximum peak output
1	Turn "Treble Tone Control" counter-clockwise so that I.F. is in "Sharp" position.			
2	2nd I.F. control-grid in series with 0.01 mf.	455 kc.	"A" Band Quiet Point at HF end	L17 and L18* (3rd I.F. Trans.)
3	1st I.F. control-grid in series with 0.01 mf.			L15 and L16* (2nd I.F. Trans.)
4	1st-Det. control-grid in series with 0.01 mf.			L12 and L13* (1st I.F. Trans.)
5	Turn Treble Tone Control full clockwise to "Broad" position. Response on CRO should be the conventional double-humped type. If necessary, retouch 3rd I.F. transformer slightly (so as not to disturb the "Sharp" curve appreciably). Leave control in sharp position for the following steps.			
6	Ant. terminal, in series with 47 minf. (link closed)	15.2 mc.	"C" Band 15.2 mc.	C21 (osc.)** C17 (det.)*** C8 (ant.)***
7		9.5 mc.	"31M" Band 9.5 mc.	C28 (osc.)** C14 (det.)*** C5 (ant.)***
8		2.44 mc.	"B" Band 2.44 mc.	C22 (osc.)** C15 (det.)**
9	Rear stator of gang, in series with 0.01 mf.	600 kc.	"A" Band 600 kc.	L10 (osc.) Rock in
10		1,500 kc.	"A" Band 1,500 kc.	C23 (osc.)** C16 (det.)**
11	Repeat steps 9 and 10.			
12	Install and connect chassis in cabinet with antenna link closed. Tune-in a radiated oscillator signal at 1,500 kc. and peak the "A" band trimmer C1 (on loop). Rock in L10 for peak output at 600 kc.			

*Adjust for coincidental curves and maximum gain.
 **Use minimum-capacity peak if 2 peaks can be obtained. (Check for correct peak on "C" band by tuning receiver to 14.29 mc., where a weaker signal should be received.)
 ***Rock in.

Calibration Scale.—The glass tuning dial may be easily removed from the cabinet and temporarily attached to the chassis for quick reference during alignment. In the event that only the chassis is returned for service, and the cabinet, with its tuning dial is left in the customer's home, the calibration scale printed in this Data Sheet can be used. Each method is described below.

Using Tuning Dial.—

- (1) Slide out the flat spring clamp at each end of the dial, and remove the glass from the cabinet.
- (2) With gang in full-mesh, move the dial pointer to the reference mark at the left-hand end of the dial backing plate.
- (3) Place the glass dial under the pointer so that the extreme left scale graduations coincide with the pointer. Use scotch tape to hold the glass dial in this position.

Using Calibration Scale.—

- (1) With gang in full-mesh, move the dial pointer to the reference mark at the left-hand end of the dial backing plate.
- (2) Place a flat, 12-inch ruler on the dial backing plate so the left-end of ruler is at the reference mark at left-end of backing plate. Temporarily fasten the ruler with scotch tape to the backing plate.

(3) Refer to calibration scale printed in this Data Sheet. This is a reduced reproduction of the dial with an inch-scale drawn at top and bottom. To find the correct pointer position in inches for any desired frequency, draw a vertical line through this frequency on the calibration scale.

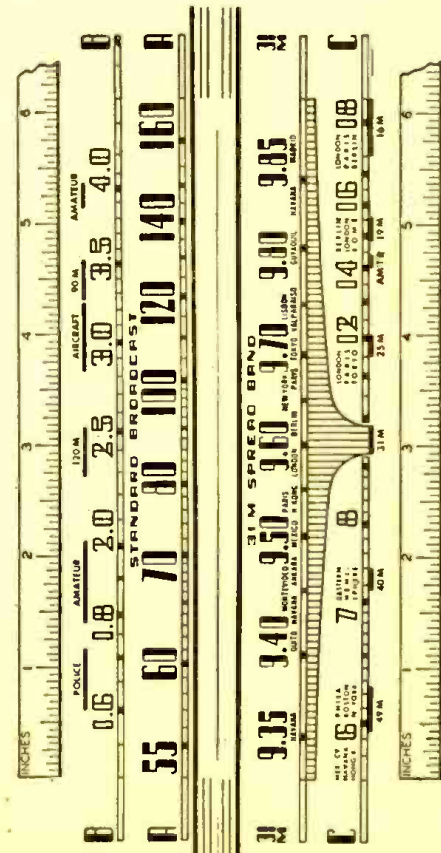
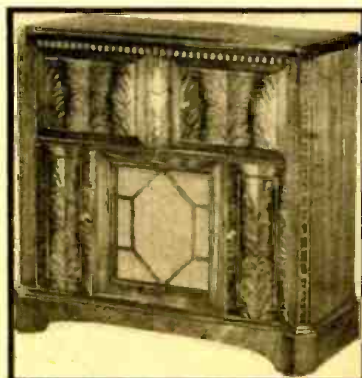

Top, adjustments for the station tuning pushbuttons. Above, the calibration chart used in aligning the receiver (see text).

▲ RCA Victor model VHR-307 receiver. This combination instrument incorporates the facilities of home recording, playback (and record phonograph), and radio receiver. The latter incorporates a "spread" band.

•SERVICING•

NEW FM AUDIO AMPLIFIERS



Designed by A. C. Shaney

FREQUENCY RANGE: 13-30,000 c.p.s. ± 1 db
POWER RANGE: 0.003 to 30,000 Milliwatts
MUSICAL RANGE: 11 Octaves
DYNAMIC RANGE: 80 db

Outstanding in their performance, construction, and appearance. These amplifiers were specifically designed for use with frequency modulation tuners, standard amplitude modulation receivers, and absolute fidelity phono reproducers. Lead, by a wide margin the very finest resistance, impedance or transformer-coupled amplifiers. Incorporate two basic AC and DC balancing circuits (Pat. app. for) which provide greater circuit stability than conventional amplifiers.

Guaranteed for FIVE YEARS

Write for literature describing our FM Amplifiers

AMPLIFIER CO. of AMERICA

17 WEST 20th STREET NEW YORK, N. Y.

of receiver, due to voltage surge and also sometimes due to the breaking-down of the electrolytic condenser.

To overcome this trouble once and for all, place in series with the plate lead of the 25Z5 rectifier (note—lead nearest the speaker field) a 2-watt, 50-ohm resistor. This will protect against such reoccurrences again. This remedy is also applicable to other radio receivers, incorporating a 25Z5 rectifier and no resistor, under the same conditions.

... A.K. 555

The complaint: audio frequency distortion. To clear this trouble it may be necessary only to replace the plate filter condenser in the A.F. circuit. This is a 4-mf. unit.

... FERRODYNE R-137 AND R-138

Oscillation or lack of sensitivity on the low-frequency band, and/or failure to align properly at the low-frequency end of the broadcast band (600 kc.), in this set, may be caused by a defective, 11-mmf. mica-and-bakelite condenser which is connected across the oscillator shunt padding trimmer.

... SILVERTONE 1640

Complaints: delayed A.V.C.; static; reception interrupted and weak. This trouble frequently is caused by a defective 0.1-mf. condenser in the A.V.C. circuit. (Note—It is sometimes necessary to replace this unit with one of 0.01-mf. Or better still, if this does not cure it, try different values as this circuit seems to be critical.) Also change the type 283 tube and at the same time, insert an R.F. choke in the plate lead of same.

... SPARTON 931

Usually, distortion, or failure to properly handle the output power, may be caused by a defective cathode bypass condenser.

... EDISON R1 AND R2

Complaints: hum; and, weak station reception.

Change the detector and 1st audio tubes. Replace with type 56 tubes in place of the present ones. It will be necessary to remove the gridleak and condenser, changing the detector bias by using a 1-watt, 45,000-ohm resistor and bypassing same with a 0.1-mf. condenser. Also change the 1st audio frequency cathode resistor resistance to 2,500 ohms, and bypass it.

... BRUNSWICK 22

Complaints: periodic reception; and noise.

To cure, replace the A.F.-circuit coupling condenser. Its value is 0.02-mf.

GEORGE F. BAPTISTE,
Howard, R. I.

... RCA 46X3

Hum, after heating up, that is not due to a defective 50L6GT output tube, or to a shot filter system, may be caused by the rectifier tube's heater wiring coming in contact with the control-grid of the 12SA7 mixer. This will have the effect of modulating the oscillator frequency and a tunable hum will be present when the receiver is tuned to a station. Off resonance, the hum will diminish. Separation of the leads cures the trouble.

... FADA 5F60-T

Intermittent howling, which stops if the set is touched, may be caused by the output tube's plate condenser opening up or coming loose, causing audio regeneration.

WILLARD MOODY,
New York, N. Y.

OPERATING NOTES

Trouble in . . .

... MOTOROLA 65

Speaker rattle on low frequencies, in this model, frequently may be cured through the use of a piece of 5/16-inch rubber cushion, such as used around car doors, windows, etc., long enough to go around the speaker rim. Mount it between the speaker rim and baffle.

... CHEVROLET 985538

Intermittent operation, and reception on only the upper end of dial, in this model, sometimes may be corrected by replacing the antenna coil, part No. 1213859. (This assembly also contains the A.V.C. load resistor and blocking condenser.)

... CHEVROLET 985537

This set sometimes exhibits high noise level.

A 0.5-mf. metal-clad generator condenser placed from spark plate to chassis housing will remove 90% of the noise. The ears on the condenser can be pushed down between the chassis and the housing, and held by the self-tapping screw already in place.

... CHEVROLET 985537

Intermittent high hum level in this set has been traced to the filter condenser, part No. 7239053, which develops a high-resistance short between sections. This is a triple-section condenser having two 10-mf., 400-V. sections for "B" voltage and a 20-mf., 25 V. section for output bypass.

... CROSLY 555

A report of "intermittent; and, reception on part of the band," in a Crosley 555, may be due to a shorted 0.01-mf. condenser from wave-switch to oscillator plate (No. 14 in diagram).

... RCA 9T2, 97K, 99K

An intermittent drop in volume may be due to defective A.F. coupling condensers.

... PUSHBUTTON SETS.

Noisy pushbuttons, in radio sets using condenser substitution methods, may be easily repaired by the following process.

Clean both bottom and top sliding contacts with carbon tetrachloride, and bend the stationary contact fingers down until a bright surface is obtained where the fingers touch.

EARL GARNER,
Knightstown, Ind.

... SPARTON 61 AND 62

Flashing of the 25Z5 rectifier is quite common, in the early models of this make



All the convenient operating features of modern engineering, all the economies of modern manufacturing, all the skill acquired in building many thousands of lathes is incorporated in the 1941 Atlas 10" and 6" Lathes.

ATLAS PRESS COMPANY

545 N. PITCHER ST., KALAMAZOO, MICH.

PATENTS—TRADE MARKS

Booklet concerning Inventions & Patents Form "Evidence of Conception" with instructions for use and "Schedule of Government and Attorneys Fees"—Free
LANCASTER, ALLWINE & ROMMEL
Registered Patent Attorneys.
436 Bowen Bldg. Washington, D. C.

• ELECTRIC EYES •

Special prices for a limited time only, on electric eye burglar alarms. These consist of: One two tube photo relay. One light source with lens, transformer and bulb. One alarm unit with relay, bell and batteries. Complete with all tubes, bulbs, cells, bell, and batteries, for only \$19.00 fob St. Charles. Sent COD or cash with order. If not satisfied return to us in good condition, in five days and money will be refunded. Cases are heavy metal black crackle finish. We can also supply these in bakelite cases resembling radios, for use in bed rooms and hotel rooms. A two piece unit having a self contained buzzer sells at \$14.50. Units operate from 110V 60 cycle current. Due to great advance in material cost, these prices are good only until present supply is exhausted.

ELECTRONIC PRODUCTS COMPANY, St. Charles, Illinois

FACTORY-TO-YOU SAVE UP TO 50%
PUT THIS NEW 1941
15-TUBE RADIO-PHONO ONLY \$22.95
COMBINATION CHASSIS IN YOUR PRESENT CABINET COMPLETE RADIO-PHONO CHASSIS WITH TUBES and SPEAKER
UP TO \$25 TRADE-IN (on Many Models)
30 DAYS TRIAL EASY TERMS
Write for FREE catalog today.
Dept. 12-JJ MIDWEST RADIO CORPORATION, Cincinnati, Ohio
HOME RECORDER FREE

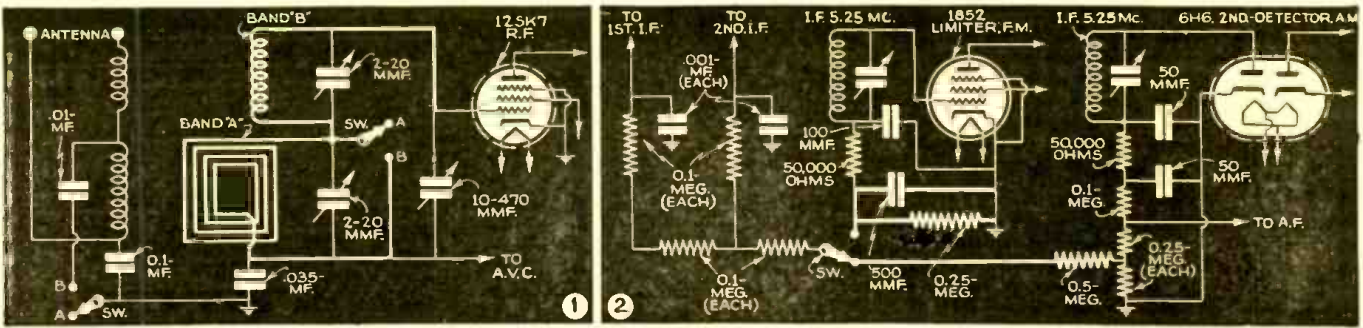

NEW CIRCUITS IN MODERN RADIO RECEIVERS

In this series, a well-known technician analyzes each new improvement in radio receiver circuits. A veritable compendium of modern radio engineering developments.

F. L. SPRAYBERRY

No. 44



(FIG. 1.) SIMPLIFIED INPUT SWITCHING PROVIDED BY LOOP CIRCUIT

RCA MODELS 16X-11 AND 16X-13.—Instead of using the loop alone for broadcast reception, the tuned circuit for the high-frequency band remains in series with it.

Though commonly done in the case of 2 or more grid coils, the association of a loop and a grid coil in this manner as in Fig. 1, represents a new and simplified circuit. The contribution of the high-frequency tuned circuit to the tuning of the loop circuit is largely inductive and constant in value. When high-frequency reception is desired, the loop is shorted. The high-frequency trimmer will affect the loop tuning adjustment only slightly but it is best in this case to make the high-frequency adjustments first. Virtually no losses are introduced into the circuit by shorting the loop as it is not magnetically coupled to the high-frequency coil except very indirectly through the antenna circuit. For high-frequency reception, however, the coupling coil to the antenna is essentially shorted.

(FIG. 2.) SWITCHING CIRCUIT ADAPTS A.V.C. TO A.M. OR F.M.

HALLICRAFTERS MODEL S-27.—The requirements for A.V.C. in A.M. and F.M. circuits differ somewhat so that when the same I.F. amplifier is used for both A.M. and F.M., a change in A.V.C. wiring must be made.

Somewhat more A.V.C. voltage is required, for A.M., and additional filtering is needed as audio changes in the unfiltered A.V.C. voltage are inherent in A.M. systems. As shown in Fig. 2, the A.V.C. line from the A.M. 2nd-detector uses a 0.5-meg. filter resistor. Moreover, the limiter and last I.F. grid are supplied in parallel, and the 2nd-detector which follows this last I.F. stage has a much greater output than the limiter input. Moreover the A.M.-A.V.C. would not be suitable for the F.M. circuit control because its activity is confined to a very narrow band of frequencies. A small stabilizing voltage over a very broad frequency band is obtained, for F.M., from the limiter-grid return with less filtering needed.

(FIG. 3.) SELF-BALANCING PHASE INVERTOR SUPPLIES OUTPUT TUBES IN PARALLEL

GENERAL ELECTRIC MODELS J-1106 AND J-1108.—Output tubes in a parallel push-pull arrangement may be driven quite as well from a high-impedance self-balancing phase inverter as an ordinary push-pull output circuit.

Figure 3 shows the circuit connections. Neither the self-balancing circuit nor the output circuit is new by itself but their combined application with degeneration introduced in the phase inverter cathode is

new. In this circuit we find the customary equalizing resistors in each output grid and unequal series grid resistors to assist in permitting more nearly equal signals from the direct and inverted grids to be applied to the output grids.

(FIG. 4.) PHASE INVERTER TRIODE COMBINED IN OUTPUT-TUBE ENVELOPE

SILVERTONE (SEARS, ROEBUCK & Co.) 7330.—A triode using a cathode in common with the regular output pentode section of the tube is used as a phase inverter.

In this circuit, Fig. 4, we find tubes of different types used in a push-pull circuit. A 6AD7G is used in one side of the circuit while a 6F6G is used in the other. The pentode section of the 6AD7G, however, has the same characteristics as those of the 6F6G. Apart from the triode connections the circuit is conventional even to the common cathode resistor for self-bias of the output tubes. The triode grid is fed roughly 1/4th of the total signal applied to the 6AD7G pentode grid in the same phase. The familiar phase reversal takes place from the grid to plate, the gain of the triode amplifier as used being about 4. Thus by being coupled to this triode plate, the 6F6 control-grid receives an equal and opposite-phase voltage from the pentode control-grid of the 6AD7G.

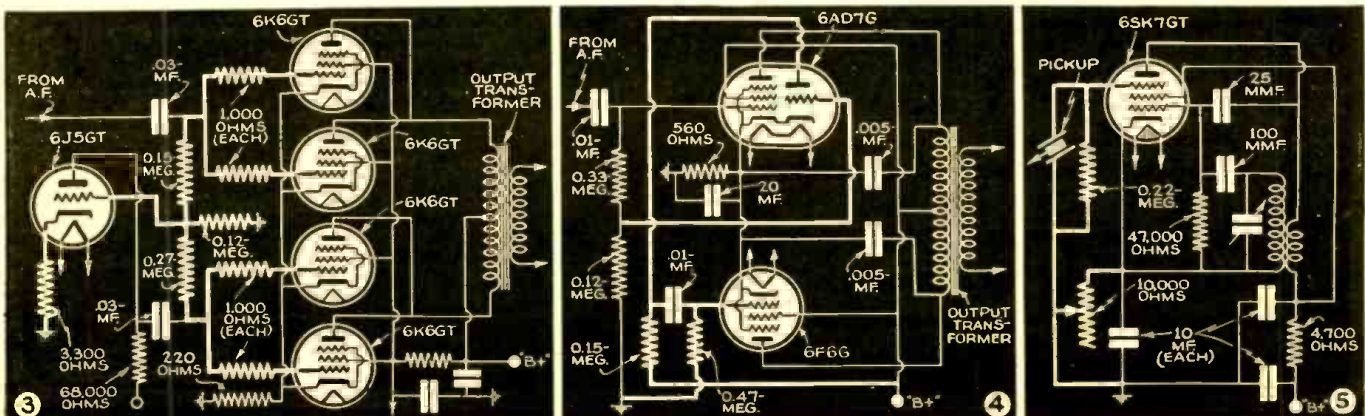

(FIG. 5.) "WIRELESS" RECORD PLAYER USES SUPPRESSOR MODULATION

MOTOROLA MODEL 22A.—An ordinary remote-cutoff pentode is used as a modulated oscillator with cathode volume control. Ordinary plate coil feedback is used and the suppressor-grid can be biased to approach plate current cutoff by means of the cathode control.

At low bias of the suppressor-grid the intensity of oscillation is large while the percentage of modulation is low. As the bias is increased the oscillation intensity is reduced but the percentage modulation is increased. Since the oscillator intensity reduces by a much greater factor than the modulation percentage increases the effect is one of a gradual control of the output. The output may be adjusted to minimum distortion using the receiver's volume control for actual control of volume. The usual "wireless" record player has no means of adjusting modulation percentage or of correction of distortion inherent in some modulated oscillator circuits.

Mr. Radio Serviceman:

Tell us about the Operating Notes—faults that occur repeatedly, in the same set model, and their repair—which you have found. We pay for all those we publish.

Catalog F40 of Atlas Sound Corporation.—This piece of literature will be of especial interest to Sound men because it includes 2 pages of photographic illustrations of practical sound installations which may serve as guides in the selection and placement of loudspeakers.

This catalog describes over 100 types of P.A. speakers and other sound parts accessories.

OPERATING NOTES

Trouble in . . .

. . . RCA R7A

The oscillator of an RCA R7A which did not align properly, and which oscillated badly, after complete check (with all voltages correct) was found to have a defective volume control. It wasn't until I had removed and replaced this unit several times, each time giving it a careful examination, that I found the control was set with an arm soldered to the back of the control by a drop of solder. Being very small, it was easily overlooked. This solder had been loosened by heat and the arm stop slid around to the wide-open position.

To correct this trouble, replace the arm and solder it down, when the resistance reading corresponds with that specified on the diagram of the set. The set will then operate perfectly.

C. L. MCGINNIS,
Adel, Ia.

. . . ZENITH 48, 106, 131 AND 132

When these receivers come in with the complaint of reception very weak, and only on the high-frequency end of the dial at all, it is due to the type 15 1st-detector-oscillator not oscillating properly. By making the changes shown in my diagram (shown here) this receiver works better than new. In the revamped receiver, no changes are made in the I.F. stage except in the filament circuit (the type 39/44 being put in the socket originally occupied by a type 15). Of course, a new socket must be installed for the 6A7. The changes shown give you A.V.C. on both the 6A7 and 39/44. Although the original oscillator coil might be OK to use

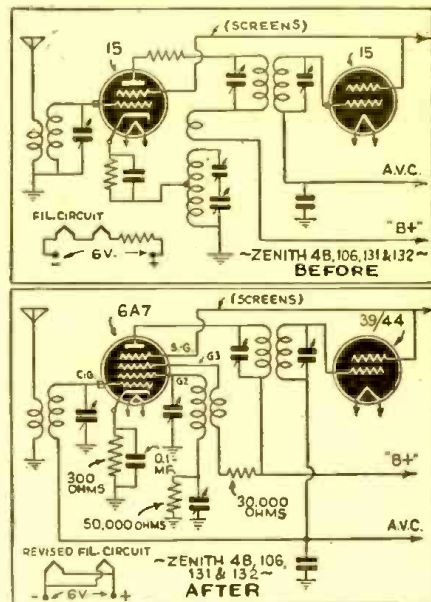

in the revamped circuit, I use a new, small, unshielded Meissner oscillator coil.

. . . ADMIRAL A.C.-D.C. MIDGET

These sets sometimes blow out one 35Z5 tube after another (also the pilot light) and show no shorts. The cure: connect a 35-ohm resistor between the plate and the filament of the 35Z5. (Originally connected together direct.) Any A.C.-D.C. receiver using this tube and having these symptoms, and having no resistance between the plate and filament

We're Not Fooling, Mr. Serviceman!

➔ **NATIONAL DUES IN THE RSA**
➔ **ARE ACTUALLY ONLY \$1.00 A YEAR**



Yes—it seemed amazing . . . incredible . . . but Servicemen found it was true. Now hundreds of applications are pouring in from all parts of the country! Just think—a full year membership in the National RSA for only \$1.00 (that's less than 2c a week).

You get the RSA Membership Certificate and the RSA House Organ. You have access to RSA Technical Help Bureau, and you can participate in all the other functions and benefits RSA offers.

RADIO SERVICEMEN OF AMERICA, INC.

"Reliable Service Assured"

JOE MARTY, JR., EXECUTIVE SECRETARY
304 S. DEARBORN ST., CHICAGO, ILLINOIS

Get the RSA Push-Button Changeover Plan

Are you ready to get your share of the Push-Button Changeover business? Join the RSA now and get the complete plan available to RSA members.

Protected territories will be established as rapidly as local chapters are formed. Applicants in present chapter areas will be referred to the local chapter.

It's your big opportunity. Fill out the coupon, attach a \$1.00 bill and mail it in today.

RADIO SERVICEMEN OF AMERICA, INC.
304 S. Dearborn Street, Chicago, Illinois

\$1.00 enclosed for 1941 National Dues in RSA.

Name

Address

City State

Radio-Craft—May

should have a peak limiting resistor of at least 25 ohms in series with the plate and filament.

... SENTINEL 86ATE

A high-pitched squeal at all settings of volume control may be caused by incomplete R.F. filtering. To eliminate this trouble, connect a mica, 350 mmf. condenser from bias cell to chassis.

... WILCOX-GAY A-93 AND A-94

If recorded "wow" is encountered in dual-speed recorder units of the automatic record changer type used in equipment bearing serial numbers prior to 624010, a correction may usually be effected by increasing the tension of the intermediate drive wheel spring. Remove 12 turns at the hook end of the spring. Straighten out 3 turns of the coiled spring, and form a new hook so that the bend in the hook is only 1/4-in. from the coiled spring. Do not make a sharp bend in forming the hook. Instead, form a 1/16-in. radius.

WILCOX-GAY,
Charlotte, Mich.

... ZENITH RECEIVERS

Many of these receivers have incorrect bias on the 1st A.F. tube, causing distortion and low, sometimes varying volume.

A simple cure for incorrect bias whether overbiased or underbiased is: ground the cathode. Ground the low end of the grid resistor. Insert a bias cell in series with the grid lead.

Some models in the Zenith line operate either on 110 V. A.C. or 6 1/2 V. D.C. by the flip of a switch. The last A.F. stage is a 2-V. tube (a 1J6), all other tubes being 6.3V. V types. This 2-V. tube receives the correct 2 V. as per diagram. As can readily be seen, the burning-out of either of the 2 pilot lights causes the filament voltage on the 1J6 tube to drop to about 1 V., causing distortion.

M. F. CROWELL, JR.,
Crowell, Texas.

Hey Fellers . . . SOS!

We're running low on op. notes for this department. Let's hear from some of you men who have never contributed before. We pay space rates for printed notes.

(In connection with the following reprint, see Editorial in this issue, Page 649)

"SAYVILLE ONCE MORE

—AN ATTACK ON THE ELECTRICAL EXPERIMENTER"

(Under the above title, the October 1915 edition of The Electrical Experimenter carried the interesting correspondence reprinted below. History is its own indisputable evidence that "history repeats itself." We can only hope therefore that a review of past events, may in some measure throw into sharp relief for all to see, the coming events which thinking men foresee.—Editor)

The two letters reproduced herewith require no comment. The one illustrates the German viewpoint, the other the American. We leave it to our readers to decide which is the correct one.

Dr. K. G. Frank, as is well known, is the present executive head of the Sayville wireless station. On August 17 the Providence Journal laid before the U. S. Neutrality Board in Washington eight formal charges. One of these charges was that Dr. K. G. Frank is the head in the United States of what is known in Berlin as an Information Bureau (secret service).

The letters follow:

ATLANTIC COMMUNICATION CO.
(Telefunken System of Wireless Telegraphy)
47-49 West Street
The Experimenter Publishing Co.,
Attention, Mr. H. Gernsback, Editor.

Dear Sir:—With regret and surprise I have read your editorial in No. 28 of The Electrical Experimenter on "Sayville."

According to my knowledge your paper is the only technical paper which joins some of the daily newspapers in the contemptible attempt to cast suspicion upon Sayville. One would at least expect that your paper would take cognizance of the fact that not only no single instance of an unneutral act can be proved, but also that there has never been any charge of such act made by any official of the United States Government.

The standard of the technical and scientific press in this country is, fortunately, so high that I am convinced your paper will remain the only one which distinguishes itself in such manner.

Very truly yours,
(Signed) Dr. K. G. Frank,

New York, N. Y., August 17, 1915.

Atlantic Communication Co.,
New York City,

Attention Dr. K. G. Frank

Dear Sir:—

The writer was indeed surprised to receive your communication of August 17. He is at a loss to understand how you could possibly misconstrue the true meaning of his editorial in view of the fact that at the time it was published Sayville had already been taken over by the Government. What the editorial meant to convey was that even though the Government had taken over Sayville, it was not at all certain that mes-

sages pregnant with unneutral information, yet harmless on their face, could not be sent in spite of all censorship. The imaginary case of the message from the "Adriatic" was cited as an illustration. Anyone by paying the usual tolls can even now send such a message. The management or the operators at the Sayville station obviously need not necessarily have cognizance that the message is an unneutral one.

That the writer's viewpoint was correct is best shown by the announcement of Secretary of the Navy Daniels under date of August 18, "that as a result of the demonstration that unneutral messages could be sent through the Sayville station he had issued orders that in all cases where the Government experts were in doubt about any message presented for sending it should be referred to Washington for judgment."

As to the second paragraph in your letter your attention is directed to page 210, September issue of The Electrical Experimenter. It gives facts with which you are doubtless familiar. These facts disclose one of the main reasons why Sayville was taken over by our Government.

Your assertion that "The Electrical Experimenter is joining some of the daily newspapers in the contemptible attempt to cast suspicion upon Sayville and, further, that no single instance of a dishonorable act can be proved, but also that there has never been any charge of such act made by any official of the United States Government," is as perverted as it is unfounded. Its tone is also resented by the writer. The Electrical Experimenter certainly never attempted to cast suspicion upon Sayville, but it has shown that the station can, and perhaps has been used to convey unneutral messages, though not necessarily with the knowledge of the management or its operators.

At the same time the writer desires to voice his opinion that there is sufficient circumstantial evidence at hand to lead anyone who wishes to view the matter in its true light to believe that the management of the Sayville station probably had some knowledge of the real purport of the many "irregular" messages sent over the Atlantic by Sayville before the station was finally taken over by the United States Government.

The slur contained in your last paragraph is best met by bringing to your attention the fact that The Electrical Experimenter to-day is considered an authority on wireless matters in this country. As such it is its duty to publish any matter of interest to the wireless world. It will distinguish itself in the future by continuing to do so. It will also continue voicing its opinion especially at times when the welfare of this country is concerned.

Very truly yours,
The Electrical Experimenter Co.
(Signed) H. Gernsback, Editor

New York, August 30, 1915.

HOW TO SAVE ON EVERYTHING IN RADIO

SEND FOR ALLIED'S NEW CATALOG

Free!

180 PAGES SHOWING EVERYTHING NEW IN RADIO

A GREAT BOOK OF RADIO VALUES

Just off the press! ALLIED'S new Spring Catalog—cramped with smashing values from cover to cover! ALLIED offers you everything new in Radio, real savings and fast service. Dealer, Serviceman, Soundman, Builder, or Amateur—whatever your interest in Radio, you'll find the new ALLIED Catalog a necessity! Send for your FREE copy today. Keep it handy for speedy reference!

NEW RADIO SETS **VALUES IN P. A.**

See them all—1941's Radio Hits! Models for every purpose. Every one a Champion—new "Personal" three-way Portables; latest Receivers; Phono-Combinations; Plastic Sets; World-wide Models; new FM-AM receivers; Auto and Farm Radios; Amateur Sets—all at lowest prices that spell Real Savings and Profits for you!

25 New Sound Systems! For every Public Address application—7 to 75 watts. Widest selection; finest features; Easy Payment Plan and 13 Day Trial. Complete P.A. necessary listings for every purpose. Dollar for dollar, you get more when you buy 1941 KNIGHT Sound Equipment. Send for your FREE catalog now!

FOR THE BUILDER **15,000 RADIO PARTS**

If you build your own, you can count on ALLIED for the latest low-cost kits and for help in building any type of radio circuit. Complete listings of the latest builders' and experimenters' supplies. New diagrams. Complete Ham Year for the Amateur. ALLIED is Headquarters for Radio Builders! For Radio Amateurs!

The biggest selection of quality parts in all radio. Every leading make—complete listings for every radio replacement and servicing requirement. Parts, tools test equipment, books, etc.—You need this reliable Guide to Everything in Radio at the lowest prices! Don't be without it! Don't wait! Mail coupon TODAY!

ALLIED RADIO

833 W. Jackson Blvd., Dept. 2-E-1
Chicago, Illinois

Send me your FREE 180-Page 1941 Spring Catalog.

Name _____

Address _____

City _____ State _____

FREE

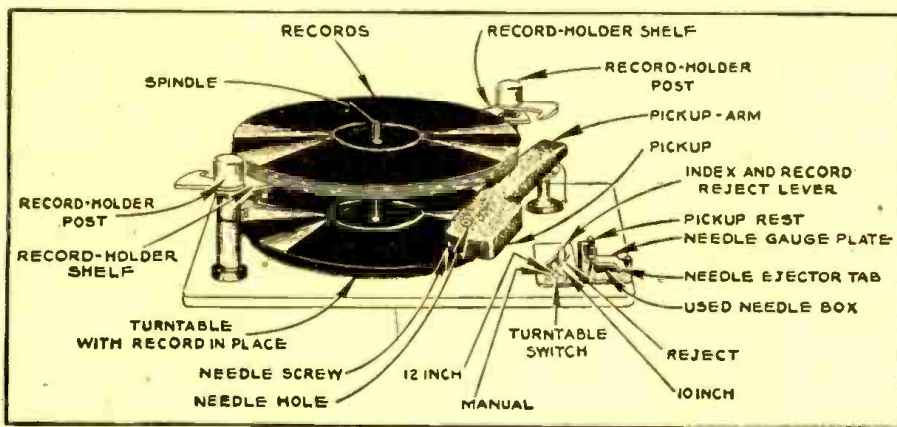

Millions of "phono-radio" sets, and "record players," are now in use. Servicing the record-playing systems—both manual and automatic—in many instances presents real problems for the technician. Mr. Moody tells how he has licked many of these "posers." The article concludes with detailed information concerning a representative type of automatic record changer.

← Top view of the RCA Victor Automatic Record Changer.

SERVICING RECORD PLAYERS

WILLARD MOODY

THE record players used in RCA, Stromberg-Carlson, Westinghouse, General Electric, Emerson, Philco and Farnsworth radio-phonographs are familiar to the writer through actual and first-hand experience. In writing this article, then, we shall try to be practical, leaving out some of the complications and sticking to the subject of what is likely to be the matter when the average unit of this kind gets out of order.

REPULSION MOTOR

First, the simple record player will have a relatively simple motor. The majority, these days, are of the rim-drive variety, although some earlier and even present-day RCA units use the induction-type motor; or rather, the *repulsion-type* motor, similar in its action to the ordinary wattmeter used on alternating current.

This repulsion type needs a push to make it start. When, having been given the necessary primary impetus, it still refuses to turn, the chances are that the aluminum piece, circular in shape, which is attached to the turntable's underside, is hitting against the rest of the motor. The RCA VA-20 is typical of this type. Frequently, too, the ball bearing on which the turntable shaft rests may need oil or may need to be replaced due to wear and tear. A steel buckshot, such as is used for toy air guns, will serve the purpose. *Lead shot will not do.*

Other troubles usually developed by this particular motor are: burned-out coils and loose wires; or, the motor switch may be open-circuited. Sometimes, the turntable will wobble too much due to loose rubber cups not holding the underside securely to the revolving disc. Duco cement fixes that.

RIM-DRIVE MOTOR

As for the simple *rim-drive* motor, friction that is lacking where it should be, or is too much where it shouldn't exist at all, are the usual faults. Taking a rag and wiping spilled oil off the rubber friction drive or rim will permit better traction.

Typical of this type is the RCA V-100, which also is sometimes afflicted very commonly with another trouble, that of mechanical noise arising out of the condition wherein the rubber sleeve or cover on the drive wheel has slipped from its proper position, with perhaps a segment of the metal exposed, so that there is an intermittent and puzzling sound that appears to be a *click, click, click*, as the motor spins around.

To digress from the subject for a moment,

in the Farnsworth automatic record changer a similar trouble very often evidences itself. That is, the turntable makes a noise as it revolves, and inspection will 9 times out of 10 show that the pin which evidently is intended for a recording blank disc has slipped down into the motor or else that the spring which props up this pin has dropped and is hitting against a motor bolt. The remedy is to push the pin out completely, with a long screwdriver; or, in an emergency, so to speak, use may be had of a long, thin-bladed kitchen knife, to pry the spring out of harm's way. The Farnsworth automatic record changer known as the P-2 is typical of this type.

D.C. OPERATION

In many sets operated on direct current, a vibrator will be used for supplying A.C. to the small phono motor, with the result that all of the troubles usually associated with vibrators are present. Electrical noise is common, but may be reduced satisfactorily by a heavy condenser (0.5- or 1 mf.) across the motor. Vibrators often have to be replaced, so check before tearing the motor apart.

On the RCA record players, the commonest trouble is that of the tone arm not swinging back to repeat the cycle, or of the tone arm not hitting the edge of the record as it should. Also quite common is the trouble which involves breakage of records due to the binding of the mechanism when a record becomes jammed in the record knives.

As for the first mentioned trouble, the tone arm swing may be adjusted by loosening or tightening a small screw at the end of the tone arm lift cable. Very often the adjustment is one to take up a certain amount of slack, when the screw will first be loosened, then turned to tighten-up on the cable, and locked in position by a nut on the screw shaft.

In some cases the opposite action may be required. If the tone arm is swung to the center, near the part of the record with no recording impressed, where the arm customarily "idles," the cable may be adjusted so that the arm is raised just 1 in. above a record on the turntable. Sometimes it is necessary to try 8 or 9 records and check the adjustment so that the underside of the 8th or 9th record will not be hit as the tone arm swings upwards and out.

With regard to repetition of the cycle, there is a small collar underneath the turntable and motor "board." It is located near the record reject lever and is a screw ad-

justment. Tightening the screw increases the pressure of the collar, and conversely, a loosening of the screw decreases the pressure. If too tight, the rejection may occur in the middle of a record; if too loose, it may take several seconds to reject—or it may fail utterly to reject.

RECORD TROUBLE

Binding and breakage of records may be due to insufficient clearance between record blades or knives. On the underside of the lowest knife in each set of two is an adjusting screw with locknut that controls the amount of blade separation. A record may be placed in position and this adjustment affected without great difficulty. Occasionally, a record knife will have a rough edge which will need to be filed, followed by a smoothing operation with fine sandpaper.

On all record players in general, of the crystal pickup type, the A.C. voltage measured with a vacuum-tube voltmeter, when the pickup is "idling at the center of a record," will be close to 2 volts. This may be used as a figure-of-merit, or criterion of crystal sensitivity, since the voltage will drop off if there is anything wrong with the pickup. A fractured or broken crystal, immediately broadcasts the fact that it is damaged, by evidencing a poor tone and low output. In automatic record changers particularly, this is apt to occur, for the tone arm will frequently be set down with too severe a shock, due to carelessness on the part of the owner or to mechanical failure in the mechanism.

LUBRICATION

In many record changers, of whatever manufacturer, oil and grease are frequently needed to ensure proper operation. In cold weather especially this will be noticed, since the oil or grease will tend to gum-up. In cases where the record player is new and has just been taken out of the carton, it may be found that it is either dried out of oil or that there was a slip-up at the factory and some one forgot to oil the machine. Those things do happen, strange as it seems. In servicing in the home, a bit of 3-in-1 oil and some vaseline borrowed from the owner's medicine cabinet will do the job.

Record player troubles that aren't really troubles at all often crop up, such as, for example, the very common one of a loose and pulled-out cable of the Philco photoelectric-cell (or lightbeam pickup) outfits. In this particular form of record player, the phono mechanism is pulled in and out to operate it, with the record player con-

cealed when not in use; the pickup lead will often come out of its jack and may be secured by simply tying it into position with a piece of tape or wire. Other troubles in this type center around the head, which may sometimes need a new pilotlight or oscillator adjustment. A high-frequency A.C. voltage is supplied to the pilotlight in the head, and anything which affects the oscillator source will, of course, affect the pickup.

Recourse should be made, wherever possible, to manufacturers' published data which are replete with full technical details needed in servicing record players. Write either directly to the manufacturer, specifying type of motor or radio set, for information required, or to your local distributor of the radio receiver or record-playing equipment that you have. Typical of such manufacturers' data, taken verbatim from the RCA Victor service bulletin on Phono-Radio models U-30 and U-129, follows:

GENERAL INFORMATION

Before servicing the automatic record changer, inspect the assembly to see that all levers, parts, gears, springs, etc., are in good order and are correctly assembled.

A bind or jam in the mechanism can usually be relieved by rotating the turntable in the reverse direction.

The changer can be conveniently rotated through its change cycle by pushing the index lever to "Reject" and revolving the turntable by hand. A total of 6 turntable revolutions are required for 1 change cycle.

The turntable, spindle, and pinion gear are assembled by means of a 3/32-inch straight pin. This pin may be removed by gently driving with a standard pin-punch.

If the record changer or cabinet is not perfectly level, normal operation is likely to be affected.

The 10 and 12 inch records must be absolutely flat for smooth operation when using a mixture of the 2 sizes.

A shorting switch, located in the pickup head, operates due to pressure when the pickup is placed on the pickup rest.

ADJUSTMENTS

(A) *Main Lever.*—This lever is basically important in that it interlinks the various individual mechanisms which control needle landing, tripping, record separation, etc. One adjustment is provided for the main lever. Rotate the turntable until the changer is out-of-cycle; and adjust rubber bumper bracket (A) so that the roller clears the nose of the cam plate by 1/16-inch.

(B) *Friction Clutch.*—The motion of the tone arm toward the center of the record is transmitted to the trip pawl "22" by the trip lever "7" through a friction clutch "5." If the motion of the pickup is abruptly accelerated or becomes irregular due to swinging in the eccentric groove, the trip finger "7" moves the trip pawl "22" into engagement with the pawl on the main gear, and the change cycle is started. Proper adjustment of the friction clutch "5" occurs when movement of the tone arm causes positive movement of the trip pawl "22" without tendency of the clutch to slip. The friction should be just enough to prevent slippage, and is adjustable by means of screw "B." If adjustment is too tight, the needle will repeat grooves; if too loose, tripping will not occur at the end of the record.

(C) *Pickup Lift Cable Screw.*—During the record change cycle, lever "16" is actuated by the main lever "15" so as to raise the tone arm clear of the record by means of the pickup lift cable. To adjust pickup for proper elevation, stop the changer "in-cycle" at the point where pickup is raised to the maximum height above turntable plate, and has not moved outward; at this

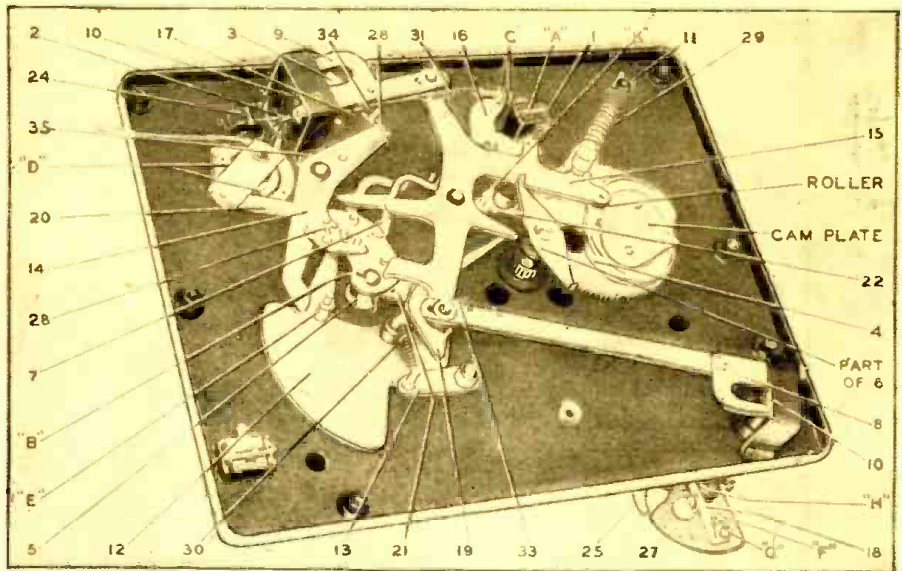

Bottom view of the RCA Victor Automatic Changer. Numbers refer to parts; letters, to adjustments.

point adjust locknuts "C" to obtain 1 inch spacing between needle point and turntable top surface.

(D & E) *Needle Landing on Record.*—The relation of coupling between the tone arm vertical shaft and lever "20" determines the landing position of the needle on a 10-inch record. Position of eccentric stud "E" governs the landing of the needle on a 12-inch record; this, however, is dependent on the proper 10-inch adjustment.

To adjust for needle landing, place 10-inch record on turntable; push index lever to reject position and return to the "10-inch" position; see that pickup locating lever "17" is tilted fully toward turntable; rotate mechanism through cycle until needle is just ready to land on the record; then see that pin "V" on lever "14" is in contact with "Step T" on lever "17." The correct point of landing is 4-11/16 inches from the nearest side of the turntable spindle; loosen the 2 screws "D" and adjust horizontal position of tone arm to proper dimension, being careful not to disturb levers "14" and "17." Leave approximately 1/32-inch end play between hub of lever "20" and pickup base bearing, and tighten the blunt-nose screw "D"; run mechanism through several cycles as a check, then tighten cone-pointed screw "D."

After adjusting for needle landing on a 10-inch record, place 12-inch record on turntable; push index lever to reject and return to 12-inch position; rotate mechanism through cycle until needle is just ready to land on the record; the correct point of landing is 5-11/16 inches from nearest side of spindle. If the landing is incorrect, turn stud "E" until the eccentric end adjusts lever "14" to give correct needle landing. The eccentric end of the stud must always be toward the rear of the motor board, otherwise incorrect landing may occur with 10-inch records.

(F & G) *Record Separating Knife.*—The upper plate (knife) "25" on each of the record posts serves to separate the lower record from the stack and to support the remaining records during the change cycle. It is essential that the spacing between the knife and the rotating record shelf "27" be accurately maintained. The spacing for the 10-inch record is nominally 0.058-inch; and for the 12-inch record, is 0.075-inch.

To adjust, rotate the knife to the point of minimum vertical separation from the record shelf and turn screw and locknut "F" to give 0.055—0.061-inch separation. Screw "G" must not be depressed during this ad-

justment. After setting screw "F" adjust screw "G" so that when its tip is depressed flush with top of record shelf, the vertical spacing between the knife, in its lowest rotational position, and the shelf, is 0.072—0.078-inch.

(H) *Record Support Shelf.*—The record shelf revolves during the change cycle to allow the lower record to drop onto the turntable. Both posts are rotated simultaneously by a gear and rack coupled to the main lever "15," and it is necessary that adjustments be such that the record is released from both shelves at the same instant. To adjust, place a 12-inch record on the turntable, rotate mechanism into cycle to the point where tone arm is at maximum distance outward from turntable; lift record upward until it is in contact with both separating knives, then loosen screws "H" and shift record shelves so that the curved inner edges of the shelves are uniformly spaced at least 1/16-inch from record edge. Tighten the blunt-nose screw "H," run mechanism through cycle several times to check action, then tighten cone-pointed screw "H."

If record shelves or knives are bent, or not perfectly horizontal, improper operation and jamming of mechanism will occur.

(J) *Tonearm Rest Support (not shown).*—When the changer is out-of-cycle, the front lower edge of the pickup head should be 5/16-inch above surface of motor board. This may be adjusted by bending the tonearm support bracket, which is associated with the tonearm mounting base, in the required direction.

(K) *Trip Pawl Stop Pin.*—The position of the trip pawl stop pin "K" in relation to the main lever "15" governs the point at which the roller enters the cam. By bending the pin support either toward or away from trip pawl bearing stud, the roller can be made to enter the cam later or earlier, respectively. This adjustment should be made so that the roller definitely clears the cam outer guide as well as the nose of the cam plate.

Lubrication.—Petrolatum or petroleum jelly should be applied to cam, main gear, spindle pinion gear, and gears of record posts.

Light machine oil should be used in the tonearm vertical bearing, record post bearings, and all other bearings of various levers on underside of motor board.

The felt washer between the turntable and spindle bearing should be soaked in light engine oil whenever the turntable is

Social Security Name Plate



Only **35¢**

Bronze Plate with your Name & Number on it

and This **GENUINE LEATHER BILLFOLD** without Extra Charge—



For the nominal amount of 35c we will send you the following values:

1. One duo-tone imperishably etched Bronze Name Plate, size 3x1 1/2 inches with your Social Security number and name permanently stamped upon it.
2. One Genuine Leather Billfold, size 8 1/4 x 3 inches in natural brown color, with four compartments, as per illustration above.

This Pocketbook is our free present to you. Absolutely no strings of any kind. We make you this gift because we expect you to do us a favor by showing your name plate to your friends, to interest them in ordering one for themselves. That's all. Help us and you will benefit yourself.

ACT NOW! Mail the coupon below and enclose 35c in coins. The bronze name plate and the Leather Billfold will be forwarded to you at once.

PREMIUM DISTRIBUTING SERVICE
 Wrigley Bldg., Chicago, Dept. RC-541

Enclosed find 35c for which mail to the address below, my Social Security Bronze Plate and the Genuine Leather Billfold without extra cost, as per your offer.

My Social Security Number is

NAME

ADDRESS

CITY STATE

ELEMENTARY MATHEMATICS

EASY — SIMPLIFIED — PRACTICAL



HERE is a book for the business man, the technician and craftsman explaining and answering every operation and meaning with interpreting illustrations and examples.

It is the key to a simple understanding of many perplexing problems in daily life.

In clear, positive and definite language, the author popularizes and clarifies every subject and helps the reader to overcome any apparent difficulty in the study of mathematics.

A real home study-course in mathematics for the student or the man who wants to achieve proficiency or desires to brush-up on his knowledge.

Entire Chapter on Special Mathematics for the Radio Technician

- CONTENTS OF BOOK**
- CHAPTER I. Arithmetic—Addition—Subtraction—Multiplication—Division.
- CHAPTER II. Factoring and Cancellation—Fractions—Decimals—Percentage—Ratio—and Proportion.
- CHAPTER III. The Metric System.
- CHAPTER IV. How to Measure Surfaces and Capacity (Geometry).
- CHAPTER V. Powers and Involution—Roots and Evolution.
- CHAPTER VI. Mathematics for the Manual and Technical Craftsman—Thermometer conversions—Graphs or Curve Plotting—Logarithms—Use of the Slide Rule.
- CHAPTER VII. Special Mathematics for the Radio Technician.
- CHAPTER VIII. Commercial Calculations—Interest—Discounts—Short Cut Arithmetic.
- CHAPTER IX. Weights and Measures—Useful Tables.

ONLY **50c** POSTPAID

TECHNIFAX

1017 S. State St. RC-541 Chicago, Ill.

Further details of the RCA Victor Automatic Record Changer showing (top) data on the motor and its method of coupling to the changer mechanism; and (bottom) details of the record shelf posts and locating-lever assembly.

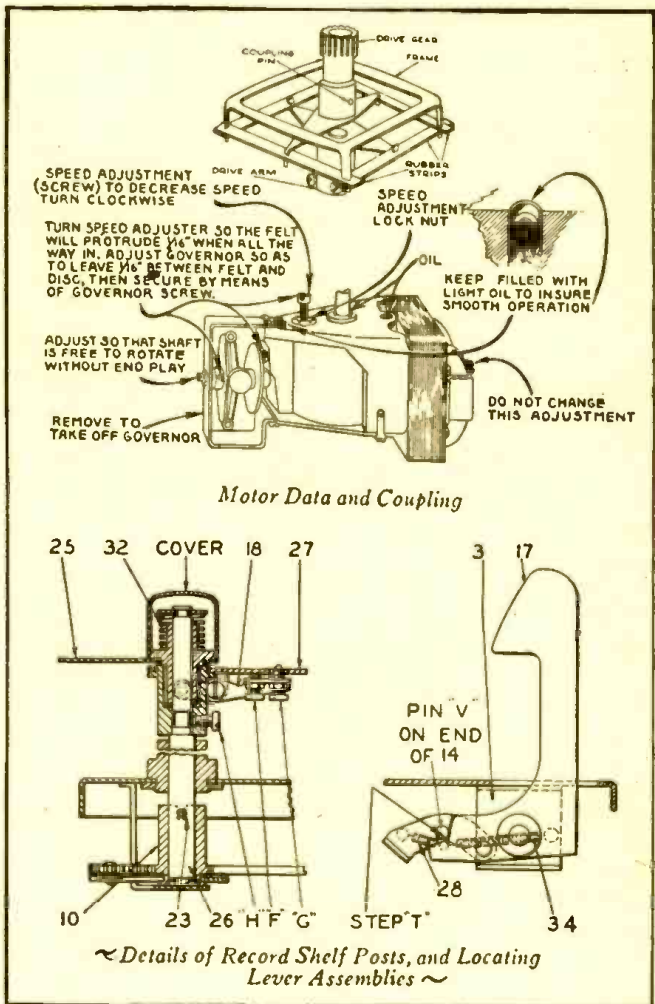

removed, or as required for proper operation.

Do not allow oil or grease to come in contact with rubber mounting of tonearm base, rubber bumper, or flexible coupling of drive motor.

MISCELLANEOUS SERVICE HINTS

Incorrect adjustment of a particular mechanism of the changer is generally exhibited in a specific mode of improper operation. The following relations between effects on operation and the usual misadjustments will enable ready adjustment in most cases.

- (1) For any irregularity of operation, the adjustment of the main lever "15" should be checked first as in "A."
- (2) Needle does not land properly on both 10- and 12-inch records.—Make complete adjustments "D" and "E."
- (3) Needle does not land properly on 12-inch record but correctly on 10-inch.—Effect adjustment "E."
- (4) Failure to trip at end of record.—Increase clutch "5" friction by means of screw "B." Also, see that levers "7" and "12" are free to move without touching each other.
- (5) Pickup strikes lower record of stack or drags across top record on turn-

table.—Adjust lift cable per adjustment "C."

- (6) Needle does not track after landing.—Friction clutch "5" adjustment "B" may be too tight; bind in tonearm vertical bearing; levers "7" and "12" fouled; or phono pickup output cable twisted.
- (7) Cycle commences before record is complete.—Record is defective, or adjustment "B" of friction clutch "5" is too tight.
- (8) Wow in record reproduction.—Record is defective; flexible coupling between motor and changer mechanism not correctly assembled; or instrument is not being operated at normal room temperature (65° F.).
- (9) Record knives strike edge of records.—Records warped; record edges are rough; or knife adjustments "F" and "G" are incorrect.
- (10) Record not released properly.—Adjust record shelf assemblies in respect to shaft by means of adjustment "H."
- (11) Needle lands in 10-inch position on 12-inch record or misses record when playing both types mixed.—Increase tension of pickup locating lever spring "34."

NEXT MONTH

Do not miss the article, "HOW TO BUILD AND USE A LEAK DETECTOR," which will appear in the June issue of *Radio-Craft*. IT'S JUST THE STORY YOU'VE BEEN ASKING FOR!

Several requirements in the I.F. channel of a frequency modulation receiver, that oddly enough sometimes oppose each other in their effect in the circuit, must be made to balance. It is these considerations which Mr. Dezettel here describes.

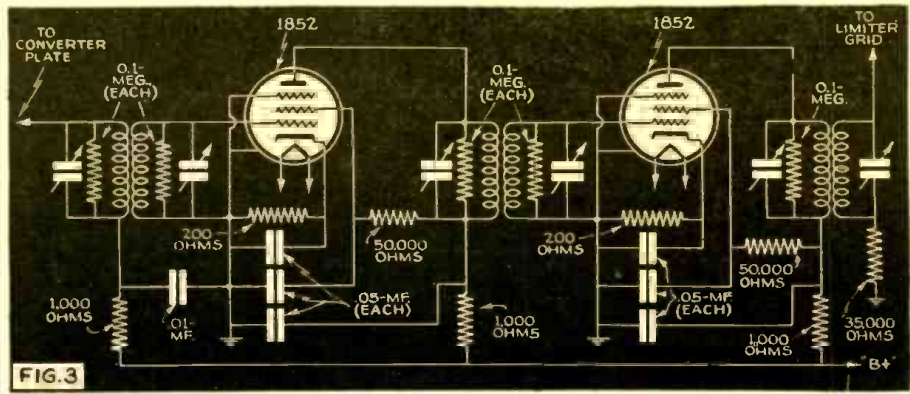

Figure 3—Schematic circuit of the I.F. channel of a representative Frequency Modulation receiver.

F. M.-RECEIVER I. F. CHANNEL DESIGN

L. M. DEZETTEL, W9SFW

EQUAL to any other consideration in proper design of a Frequency Modulation (F.M.) receiver is the I.F. channel. Several requirements must be met that are not common to Amplitude Modulation (A.M.) receivers. These requirements, oddly enough, sometimes oppose each other in their effect in the circuit, and it becomes necessary to strike a balance between them.

BAND-WIDTH

Number 1 on the list of considerations is *band-width*.

You already know that extremely wide band-width is required. Unlike the I.F. channel in A.M. receivers, it is not frequency response that is affected by lack of sufficient band-width—it is *dynamic range*. The frequency deviation is directly related to volume of audio signal. It is the *rapidity* of the frequency deviations that determines the audio frequency response. Insufficient band-width, then, results in the music or speech being compressed. The difference between loud and soft passages of music, for instance, will be less than it should be.

The original band-width recommended for the I.F. channel was 200 kc. This width is more, however, than is actually being used in practice. Commercial receivers today are being made with a band-width of 150 kc. This amount is based on a frequency deviation of 75 kc., the maximum used in F.M. broadcasting today.

How do we accomplish such band-width? By the simple expedient of increasing the coupling between windings; and, loading both primary and secondary with resistors. Curves, Fig. 1, are shown picturing the response of a single transformer for various degrees of coupling and loading. These curves show the effect on the shape of the envelope and not the resulting gain. Actually we have reduced the gain by lowering the effective "Q" of the windings by the addition of the shunt resistors; and since greater band-width requirements necessitate increased coupling, an I.F. characteristic free from "double hump" response will require a lower value of resistance in shunt with the windings.

GAIN-PER-STAGE

Consideration No. 2 in the design of the I.F. channel is *gain-per-stage*.

It follows that with coil "Q" reduced, resulting in loss of gain, more I.F. stages are required. Whereas the average gain-per-stage in A.M. receivers with a 456 kc. band-width is about 80, the figure for the average F.M. receiver is only 20.

One extra I.F. stage and one extra R.F. stage are usually employed to make up for the loss. (Note: Although the limiter stage

is part of the I.F. channel, it does not add to the gain appreciably and is, therefore, not considered in this article.) The use of the 6AC7/1852 type tube adds considerably to the gain. This tube is particularly suited for use in F.M. receivers. It was designed especially for television amplifiers where design considerations are very similar to F.M.

IMAGES

Since F.M. receivers must operate exclusively at ultra-high frequencies, the reduction of *images* is another important consideration.

The I.F. channel is called upon to perform this function by operating at a high intermediate frequency. The 4,300 kc. I.F. transformers are fast becoming the standard intermediate frequency. Thus, then, the "image" must be twice 4,300 kc. or 8,600 kc. above the incoming frequency before it could pass the I.F. channel. It is not difficult for the input circuits to reject signals 8,600 kc. off-resonance.

High-frequency I.F. transformers do not have the gain generally associated with 456 kc. transformers, for instance. But we must load our circuit with resistors anyway which forces us to accept even less gain-per-stage than normally would be obtained. So we see that the use of higher-frequency I.F. stages does not make the matter worse.

OTHER CONSIDERATIONS

Many other considerations must be kept in mind. They concern mostly detail of construction and would not be very interesting reading matter.

Some manufacturers of I.F. transformers for F.M. receivers have kept the home constructor in mind in their design considerations. One manufacturer, at least, has designed his transformers so that the selectivity curve shows a slightly rounded nose. This is done purposely to aid the home constructor in lining-up his I.F. channel. A 0.1 ma. meter is inserted in the grid circuit of the limiter stage, and the preceding I.F. transformers are adjusted for maximum meter reading with an unmodulated signal from the signal generator fed into the receiver. The limiter stage will flatten out the curve; so it is not necessary to worry about a perfectly flat nose in the I.F. channel. This is shown in Fig. 2, in which the overall response action of the limiter is shown in dotted lines.

The double peak or "stagger" method of aligning an I.F. channel should be avoided. This method of tuning tends to produce transients which will affect the quality of reproduction.

The diagram, Fig. 3, is representative of

standard practice in the wiring of an F.M. I.F. channel.

This article has been prepared from data supplied by courtesy of Allied Radio Corp.

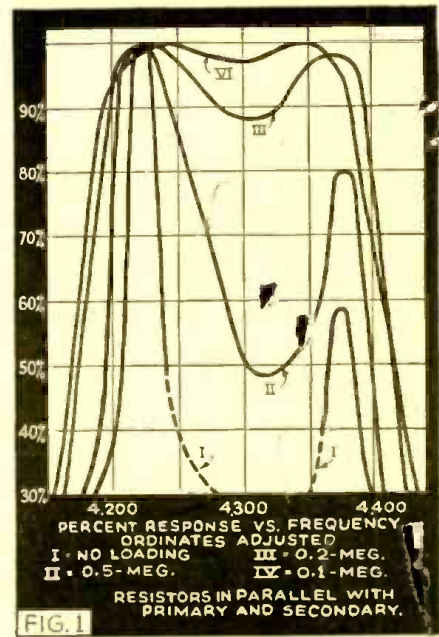

FIG. 1

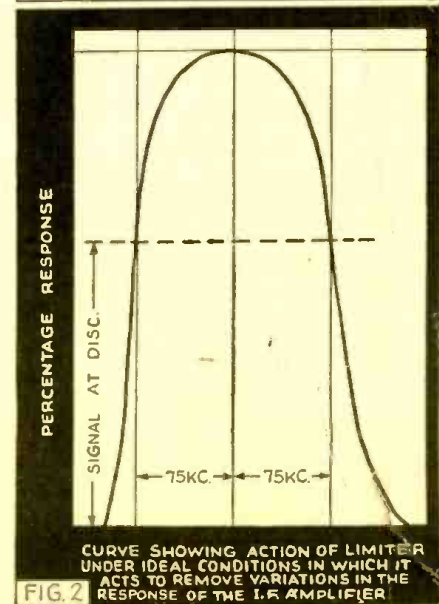

FIG. 2

• LATEST RADIO APPARATUS •

FLUSH WALL RADIO

Flush Wall Radio Co.
57 State St., Newark, N. J.

NOW every home can have built-in radio in every room at very low cost. Each radio is complete and does not depend upon interconnections with a "master receiver." To install it, it is merely necessary to cut a hole in the wall between two adjacent studs and insert the receiver which is contained in an approved fireproof steel box. The receiver is a 5-tube broadcast unit of conventional design. Front panels can be had to match color schemes of individual rooms.—*Radio-Craft*

DUAL-SPEED RECORDING MECHANISM

Speak-O-Phone Recording Co.
23 W. 60th St., New York, N. Y.



MODEL 9MA is a 78 and 33 1/3 r.p.m. recording mechanism characterizing constant speed of operation. Its turntable is 12 ins. in diameter, weighs 7 1/4 lbs., is made of cast aluminum, and is rim driven. The drive consists of a positive clutch assembly employing 4 precision-machined gears. The pickup is of the tangent, crystal type. The cutting head has a spring adjustment for regulating pressure; and, a cutting-angle adjustment which permits the use of various types of needles. The entire assembly mounts on a 15 x 15 inch steel panel 1/2-in. thick. May be used with any good A.F. amplifier or radio set.—*Radio-Craft*

DISTORTION ANALYZER

Hewlett-Packard Co.
Palo Alto, California



MODEL 320A Distortion Analyzer is a convenient instrument for measuring harmonic distortion in audio frequency apparatus. It is ideal for production work since it is easy to operate, and provides a rapid and accurate check for normal operation.

Essentially, it is a comparison device used to compare the distortion content of the wave with the fundamental voltage. When this comparison is made with a cathode-ray oscilloscope, the type of distortion can be conveniently observed. The various order harmonics will show up on the oscilloscope pattern, the hum voltage and noise voltage will appear, and a great deal of information about the voltage being analyzed can be obtained. It is designed for measurement at 400 and 5,000 c.p.s. Its input impedance is at least 20,000 ohms. A bridging transformer may be used to increase the input impedance. Concerning its distortion range, values as low as 0.1% of the fundamental may be measured with a detector of suf-

ficient sensitivity. Its filter circuits provide more than 60 db. of attenuation of the fundamental.—*Radio-Craft*

COMPACT BATTERY-TYPE TRANSMITTER - RECEIVER

TayBarn Equipment Co.
135 Liberty St., New York, N. Y.

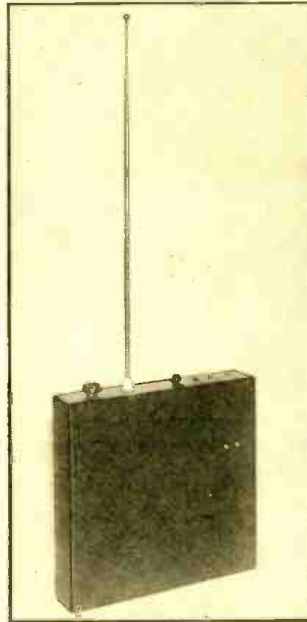

MODEL TR-10 is a compact, portable, Ultra-High Frequency Transmitter and Receiver in a single housing. It is designed especially for military radio use. Also applicable for forestry, marine and other non-military services.

It is available in 2 types; one with 4-tube superhet. receiver using fixed tuning at any frequency from 1,500 kc. to 6.5 megacycles, and the other a 3-tube superregenerative receiver with fixed tuning at any frequency from 28 to 80 megacycles. Both types have a 4 to 5 watt (R.F.) transmitter, complete with modulator stage, for radiophone transmission. The range is 10 to 100 miles depending upon altitude of transmitter or receiving station. Fixed-tuned transmitter and receiver circuits require only off-on operation of the power switch to put the instrument into instant operation on a pre-selected frequency. All batteries are self-contained.—*Radio-Craft*

"FOREIGN CORRESPONDENT" RADIO SET

RCA Mfg. Co.
Camden, N. J.

APPROPRIATELY named, this table-model dual-band receiver uses the well-known "Overseas Dial" (first introduced on consoles) which spreads out the popular 25 and 31 short wave bands to many times their normal space on the dial. Aside from the standard broadcast band, it has a foreign band coverage of from 8,600 to 12,000 kc. It is a 5-tube set with a P.M. dynamic speaker and designed for A.C.-D.C. operation.—*Radio-Craft*

"SOUNDMIRROR"

The Brush Development Co.
Cleveland, Ohio

THIS equipment records sound magnetically on an endless steel tape. The sound may then be "erased" at will and new messages recorded. Recordings may be played over and over again indefinitely. Excellent equip-

ment for educational institutions, particularly in voice-training schools. The performance is extremely simple, the only adjustment being made by the user is the playback volume. Starting and stopping are effected by ordinary pushbuttons.—*Radio-Craft*

RADIO COMPASS AND RECEIVER

The Hallicrafters, Inc.
2611 S. Indiana, Chicago, Ill.

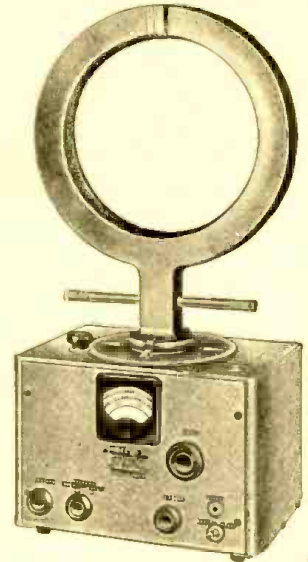

MODEL S30 is a compact combination Radio Compass and Receiver, designed for use on small boats. Uses signals from regular beacon stations for direction finding.

Its 3 bands include the 220-540 kc. beacon band, 535-1,340 kc. broadcast band, and 1,200-3,000 kc. marine band. Accurate null indications are provided both visually by a tuning eye and aurally by phones. Other features include a "sharpness" control and a switch-controlled static filter. All power is drawn from a 6-volt battery through the medium of a vibrator power pack. The entire unit measures 11x10x7 1/2 ins. high. With the loop, the overall height is 23 1/2 ins.—*Radio-Craft*

ALL-METAL MERCURY SWITCH

Durakool, Inc.
1010 N. Main St., Elkhart, Ind.

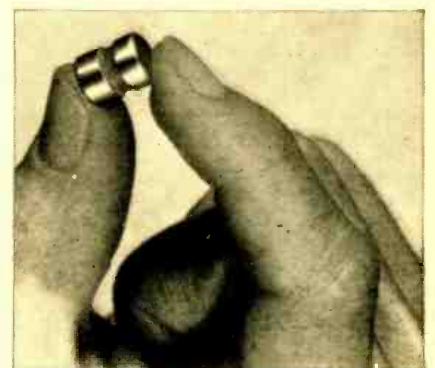

THIS inexpensive, all-metal mercury switch called the "Tiny Tipit" has a capacity of 1/2-ampere at 24 volts to 4 ampere at 6 volts. Has no moving parts (excepting the mercury pool). It operates on a tilt of 20° or more. Although designed for use on automobiles to turn the trunk light on when the lid is open, it may be used for many other purposes. Measures only 7/16x3/8-in. dia.—*Radio-Craft*

HANDY PRODUCTION TOOL

Independent Pneumatic Tool Co.
600 W. Jackson Blvd., Chicago, Ill.



K NOWN as the Pix-Up Finder, this portable electric machine which sorts, picks up and holds screws for driving, eliminates much of the hand operation ordinarily incidental in screw-driving assembly operations. Other Thor production speedup tools available are drills, nut setters, grinders, sanders, polishers, saws, and a new sheet metal cutting tool known as the Portable Nibbler.—Radio-Craft

HIGH-SPEED LEVEL RECORDER

Sound Apparatus Company
150 W. 46 St., New York, N. Y.

THE model PS Recorder is an instrument designed to make a permanent, continuous record of the variation of intensity of any electrical signal, on either a linear or logarithmic scale. It is especially designed to record rapid changes of intensities over a wide range, can be used for: transmission measurements; radio measurements; acoustic measurements; noise and vibration measurements; and, speech and music.

This model possesses 1 writing and 1 paper speed. Other models are available possessing more than one speed. Model PS has a writing speed of 0.0188-mm. per second. The apparatus weighs 20 lbs., and measures 8x10x12 ins.—Radio-Craft

AIRCRAFT PORTABLE RADIO

Sentinel Radio Corp.
2020 Ridge Ave., Evanston, Ill.

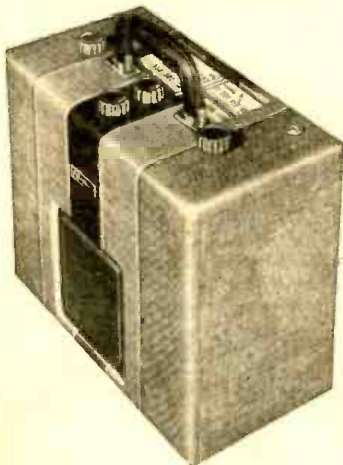

A DUAL-PURPOSE portable radio receiver designed for use by airplane pilots and boat owners. The instrument is capable of receiving beam signals on the high-wave band (140-410 kc.). The instrument can also receive weather signals, navigation reports, and radio compass signals.

Other features include a filter switch which cuts down volume of the beam signal to permit audible reception of weather reports and other communications; R.F. stage on all bands; headphone jack for noise-free reception in places where outside noises interfere with loudspeaker use; operation from self-contained batteries as well as the A.C. or D.C. electric line. In addition to all this, the instrument can receive standard broadcast stations.—Radio-Craft

PLUG-IN TUBE-TYPE RESISTORS



Clarostat Mfg. Co., Inc.
285 N. 6th St., Brooklyn, N. Y.

FOR extra-heavy-duty service such as in sets employing 150 and 300 milliamper tubes, served by a single voltage drop resistor, this new glass-insulated-element plug-in tube-type resistor is just the thing. The resistance element is wound on a fibre-glass core instead of mica and is then covered with a fibre-glass braiding. The element is then able to handle 3 times the watts power of the usual bare winding.—Radio-Craft

TRIANGULAR SPEAKER CABINET

Atlas Sound Corp.
1443 39th St., Brooklyn, N. Y.

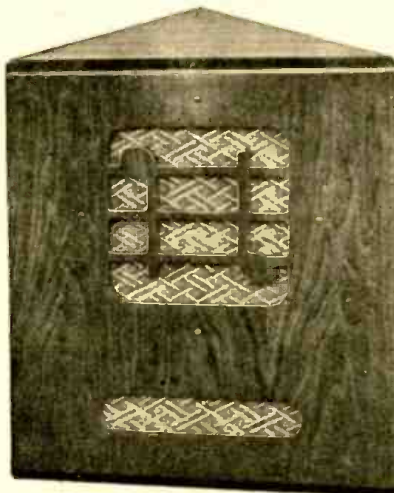

ONE of a new line of "Tri-Angle" acoustic enclosures. Excellent for corner mounting, side wall hanging and cluster arrangement in groups of 2, 3 and 4. Excellent as extension loudspeaker for coin phonographs. The construction is such as said to give infinite-baffle and bass-reflex characteristics. Illustrated is model TR-12 for 12-inch speakers. Measures 19 ins. wide x 10 ins. deep. Has overall height of 22 ins. The cabinet is made of natural grain walnut and has an attractive grille with a musical motif.—Radio-Craft

8-WATT PORTABLE P.A. SYSTEM

Erwood Sound Equipment Company
223 W. Erie St., Chicago, Ill.

DESIGNED especially for small installations in churches, schools, clubs, lodges, etc., this 8-watt portable system includes



Now— You Can ELECTROPLATE EASILY WITH A BRUSH

SOMETHING new for radio men— something which gives you the opportunity to make additional profits—or to improve your type of service. Here's an **ELECTROPLATING KIT** amazingly simple to operate—you just Electroplate with a Brush!

NOT A TOY!

Electroplate for profit, hundreds of things in the household—ashtrays, fixtures, water faucets, worn brackets, door knobs, musical instruments, jewelry and silverware and other articles. It's an indispensable piece of equipment—plate articles in hotels, apartments, office buildings, medical and dental offices, factories, schools, laboratories, etc. Exactly the same outfit (but larger) is used professionally by electricians, radio service men, automobile repair shops, etc. Requires one single dry cell 1 1/2-volt battery to operate.

You can electroplate tarnished receiver parts, switches, contacts, worn radio parts and accessories, and display chassis. Buy this **REAL ELEC-TROPLATING KIT** to use immediately—make it the most useful article in your shop or laboratory. And you can get it absolutely **FREE** (except for slight mailing cost).

Subscribe today to **RADIO-CRAFT** for One Year (12 issues) and receive absolutely **FREE** this **ELECTROPLATING KIT**. New subscribers are accepted or extend your present subscription twelve months. Mail remittance of \$2.00 (plus 10c for shipping charge on kit) to the publishers. (Canada and foreign \$2.85). You will receive your **FREE, REAL, ELECTROPLATING OUTFIT** by return mail. Use coupon below to enter subscription.

RADIO-CRAFT

20 Vesey Street

New York, N. Y.

RADIO-CRAFT RC-541
20 Vesey Street, New York, N. Y.

Gentlemen: Enclosed find my remittance of \$2.00 for which enter my subscription to **RADIO-CRAFT** for One Year (12 issues). Send me **FREE, ELEC-TROPLATING OUTFIT** (Canada and foreign \$2.85). In U. S. add only 10c additional to cover shipping charges on kit.

New Subscriber Extend Present Subscription

Name

Address

City State

(Send remittance by check, money order or un-used U. S. Postage stamps. Reletter letter if you send cash or stamps.)

• LATEST RADIO APPARATUS •

OPPORTUNITY AD-LETS

Advertisements in this section cost 15 cents a word for each insertion. Name, address and initials must be included at the above rate. Cash should accompany all classified advertisements unless placed by an accredited advertising agency. No advertisement for less than ten words accepted. Ten percent discount six issues, twenty percent for twelve issues. Objectionable or misleading advertisements not accepted. Advertisements for June, 1941 issue must reach us not later than April 7th.

Radio-Craft • 20 Vesey St. • New York, N. Y.

BOOKS AND MAGAZINES

ASSURE YOURSELF OF GREATER PROFITS BY doing radio service jobs more quickly. Authentic service guides show you the way to locate and correct troubles in any radio receiver. Gernsback Official Radio Service Manuals show you how to complete more repair jobs in less time—how to earn more money by faster servicing. Radio-Craft Publications, 20 Vesey St., New York City.

WE HAVE A FEW HUNDRED RADIO ENCYCLOPEDIAS, by S. Gernsback, second edition, originally sold at \$3.98. Book has 352 pages, weight 3 lbs., size 9 x 12 inches. Red morocco—keratol flexible binding. Send \$2.49 in stamps, cash or money order and book will be forwarded express collect. Technifax, 1915 So. State Street, Chicago, Illinois.

WHAT DO YOU KNOW ABOUT AMPLIFIERS AND Sound Systems? The Amplifier Handbook and Public Address Guide covers P.A. from A to Z. Most complete and authentic book published on the subject. Contains 80 pages of vital information on Amplifiers, P.A. Systems, Speakers, Accessories, Pickups, Microphones, etc. Printed on fine coated stock, with numerous photographic illustrations and explanatory diagrams, and only 25c. See page 672.

EDUCATIONAL COURSES

CORRESPONDENCE COURSES AND EDUCATIONAL books, slightly used. Sold, Rented, Exchanged. All subjects. Satisfaction guaranteed. Cash paid for used courses. Complete details and bargain catalog FREE. Write Nelson Company, 500 Sherman, Dept. B-242, Chicago, So.

FLUORESCENT LIGHTING

24" FLUORESCENT BENCH LIGHT \$1.49. LESS TUBE. Harold Davis, Jackson, Mississippi.

MANUSCRIPTS WANTED

WANTED—MANUSCRIPTS, POEMS, SONGS FOR publication. Fortune's, 87 Fifth Ave., New York.

MOTION PICTURES

GENERA FILMS FOR MOVIE CAMERAS. SAVE 50%. Two films "The End," 10c. (Size?) Bargain circulars. Fromaders, Davenport, Iowa.

PHOTOGRAPHY

1/100,000 OF A SECOND SPEED FLASH UNIT FOR Stroboscopic Photography, \$200.00. Apt. 63, 782 West End Ave., New York City.

RADIO

SACRIFICE! 12-TUBE LINCOLN SUPER-DELUXE All-Wave Receiver, complete with 12-inch electrodynamic speaker and separate power pack. Cost originally \$145. Will sacrifice for \$25.00. Set is 1933 model, rarely used and in good working condition. Excellent sensitivity and selectivity. A resonance tuning meter, wave-band switch, phonograph input terminals, an ideal set for the DX fan. Excellent tonal fidelity. All components mounted on a beautiful chromium-finished chassis. Rush! First come, first served! D. Kreiselman, 1430 Ocean Ave., Brooklyn, N. Y.

WANTED—ELECTROLYTIC DETECTOR, TUSKA "Superdyne"; Adams-Morgan wooden-case, brass-plate variable condenser; Bunnell 1" sparkcoil. Have radio sets, meters, etc.—or what do you want? R. Bernard, 40 Manning Ave., No. Plainfield, N. J.

RADIO KITS

RADIO KITS—\$3.95 UP. SINGLE BAND; ALL WAVE. 5-10 tubes. Fluorescent lighting. Save 50%. McGee Radio, P-2055, K.C., Mo.

TECHNICAL ART SERVICE

DRAFTING AND ART SERVICE—A COMPLETE Service for the Industrial and Commercial Marketers. If your business or plant can't afford a designing or drafting staff, don't let this stop you from going ahead with that new product you intend marketing, or that catalog of mechanical or electrical items which needs fine detailed drawings and highly retouched photographs. Any mechanical, electrical or radio problem can be solved for you by our associated staff of designers, draftsmen and artists, and technical copywriters. Write for any additional information as to methods and price for this service. Tec-Art Drafting Service, 228 Charlotte Terrace, Roselle Park, N. J.

DRAFTING SCHEMATIC DIAGRAMS SEND US A rough sketch of your circuit. Estimates by return mail. Our prices are moderate; our work guaranteed. No jobs too big or small. Wm. Kadlecik, Jr., 440 East 85th St., New York, N. Y.

RADIO RESEARCH BUREAU

Technical questions, engineering data, write for quotation. Radio receiver design, electronic, mathematics, physics, statistical surveys at economical rates.

Address: Willard Moody, 403 West 205 St., N.Y.C.

amplifier, desk-type crystal microphone and a 10-inch P.M. dynamic speaker. Provision is made for attachment of a record playing mechanism. Tone control allows tone to be adjusted to suit acoustical conditions. Entire assembly contained in a single carrying case measuring 14x11x12 ins. high, and weighs less than 28 lbs.—Radio-Craft

F.M. STATION MONITOR

General Electric Company
Schenectady, N. Y.



DESIGNED exclusively for frequency modulation work, this new unit performs the functions of a Center-Frequency Monitor, Modulation Monitor, High-Fidelity Audio Monitor, and Modulation-Limit Indicator of the flasher type.

Center frequency deviation and percentage of modulation are read on illuminated meters. The self-contained crystal standard provides for instant calibration of the center-frequency deviation instrument at a flip of a switch. The frequency response of the audio monitor is better than 1/2 db., from 30 to 15,000 cycles. The modulation limit flasher is adjustable to show whenever modulation exceeds the value for which the panel control is set—the range being from 50 to 120%. Other features: built-in voltage-regulated power supply, and a *de-emphasis* circuit on the audio monitor.—Radio-Craft

CONDENSER ANALYZER

Solar Manufacturing Corp.
Bayonne, N. J.

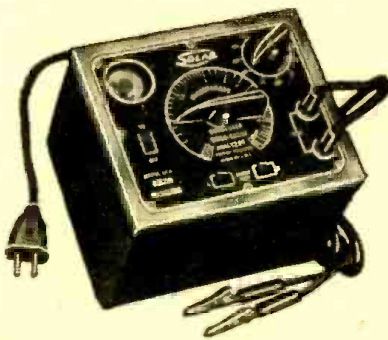

THIS new "quick-check" condenser analyzer affords both qualitative and quantitative tests. Known as model "QCA," it indicates leakage, insulation resistance, R.F. impedance, power factor, capacities and in addition, affords a dynamic check for shorts, opens, and intermittents.—Radio-Craft

ROD ANTENNA COMMUNICATIONS

Vetrod Mfg. Co.
132 Nassau St., New York

ALTHOUGH this is said to be an all-wave rod antenna, it is so designed as to be peaked for maximum efficiency on the 10-, 20- and 40-meter bands. Both amateurs and owners of all-wave receivers will welcome this conveniently-installed, non-directional rod antenna.—Radio-Craft

PRESSURE-OPERATED DYNAMIC MICROPHONE

RCA Mfg. Co.
Camden, N. J.



MODEL MI-6206 is a new, lightweight "Aeropressure" microphone especially designed for announcing and remote pickups. Ideally suited for outdoor use. A "paracoustic reflector" adjusts the pick-up pattern to suit individual requirements. The mike has a *styrol* (plastic) diaphragm and a moving coil element. Its frequency range is 60 to 10,000 cycles; output impedance, 250 ohms; output level (10 bars) 59 db. (0.006-watt) open circuit. Available in low-impedance (250 ohms) and high-impedance (40,000 ohms) types.—Radio-Craft

NEW DIAL FOR SELF-CALIBRATION

National Company
Malden, Mass.

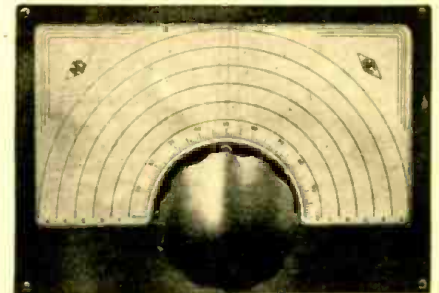

THE type ACN dial here illustrated should prove to be a boon to all individuals who construct their own radio apparatus such as oscillators, receivers, transmitters, etc., since its 5 range scales can be calibrated by hand. To facilitate calibration, a 0 to 100 division linear range is provided. The transparent lucite pointer has a black etched hairline for accurate reading. A bezel holds the dial scale and its transparent lucite window in place. Two extra dial scales are supplied with each dial. The tuning ratio is 5 to 1 and is designed to be used with a 180° rotation condenser having a 3/4-inch diameter shaft. The dial frame measures 5x7 1/4 ins.—Radio-Craft

PRIVATE-PLANE RECEIVER

RCA Mfg. Co.
Camden, N. J.

A CUSTOM-BUILT receiver has been developed which covers both the standard broadcast band and the weather band of the C.A.A. In addition, it can receive the radio range signals for navigation purposes. Designed especially for the 1941 Piper Coupe airplane, the receiver has a range of 250

miles and gives excellent performance without the necessity of shielding the ignition system. The set is completely self-contained and is operated by a vibrator powered from the plane's battery, which in turn is charged by a wind-driven generator. Another feature includes dual phone jacks for pilot and passenger.—*Radio-Craft*

OIL-FILLED CONDENSERS

Aerovox Corporation
New Bedford, Mass.



MIDGET, oil-impregnated, oil-filled condensers in handy tubular form, are finding many uses in radio assemblies, particularly for vibrator applications, coupling functions, low-power transmitters and trans-receivers, television receivers, amplifiers, and in many laboratory applications. New units in an inexpensive "-89" series are housed in cadmium-plated brass cans, hermetically sealed. They are available in 400, 600, 1,000 and 2,000 volt ratings and in capacities from 0.006-mf. to 0.5-mf.—*Radio-Craft*

STATION LOCATOR

Allied Radio Corp.
833 W. Jackson Blvd., Chicago, Ill.

DEMANDS for readjustment of push-buttons, due to frequency reallocation, will continue for quite some time after March 29th. This new Station Locator will aid considerably in cutting the time necessary to readjust the push-buttons. No direct connection to the set is necessary. A drift-free oscillator generates either a modulated or unmodulated signal at the flip of a switch. The range covers the entire new broadcast band and the frequency is easily read on a simply-calibrated dial. Operates on self-contained batteries. Measures 3 x 4 x 5 ins. high.—*Radio-Craft*

Sivils, an elaborate and unique drive-in restaurant located on the Ft. Worth pike, near Dallas, Texas, has glamourgals, hamburgers, and an extensive sound system, Mr. Hix Smith advises *Radio-Craft*. The sound installation utilizes a lookout in a control tower atop the restaurant. He is equipped with field glasses, and a microphone that feeds a public address system. When a car arrives on the lot, the spotter assigns a girl car-hop to the vehicle via P.A. She places on the windshield a menu which carries the instruction to "flash headlights for service." This method of silent summoning does not interfere with the music from an electric phonograph. A 35-watt amplifier, 5 outside and 8 inside loudspeakers, 3 microphones, and an electric phonograph with automatic record changer constitute the entire sound system.

It is estimated by N.B.C. that if every motion picture house in the country is filled every night there would be still 80,000,000 radio listeners outside the theatre. According to this arithmetic, "the theatre" need not take too seriously the perennial bleat that radio is ruining theatre attendance.

A NEW BOOK TO ADD TO YOUR TECHNICAL LIBRARY

AUTOMOBILE RADIO — Principles & Practice

by B. Baker Bryant



50c

POSTPAID

Size—6 x 9
Inches
64 Pages
Stiff, flexible covers
Numerous Illustrations and diagrams

A COMPLETE compilation of pertinent data on how to install and service the modern automobile radio receiver. All of the non-essential details which have crept into the profession have been weeded out. Each topic is treated so as to contain a precise statement of the fundamental principle involved, to assure the reader's clear understanding of this principle, without distracting his attention by the discussion of a multitude of details and mathematical expressions, which are primarily for the engineer, and tend to confuse rather than clarify a statement for the auto-radio technician. A practical treatise based on practical experience by practical radio people for the practical radio-technician.

Brief Outline of Contents—

Introduction—The Auto-Radio Art.
Features of the Modern Automobile Receiver.
Installations of Automobile Radios and Antenna.
The Automobile High and Low Tension Electrical Systems.
Automobile Electrical Disturbances.
Vibrator Converters and Motor Generators.
Service Hints, Classified Automobile Installation Notes, and Conclusion.

Send 50c check, money order, unused U. S. stamps, or coin for your copy of "Automobile Radio—Principles & Practice"—it will be sent to you postpaid upon receipt of your remittance.

RADCRIFT PUBLICATIONS, Inc.
20 Vesey Street, New York, N. Y.



FLIGHT THE PICTORIAL FLYING REVIEW

Brings you all the phases of world aviation and aeronautics in a non-technical yet educational manner—exciting articles which catch your breath, yet give you the fundamentals of flying and ALL related subjects. **FLIGHT** keeps you abreast of all the major developments as fast as they appear anywhere. Now, when planes and flying are of vital importance to all, you just can't do without this richly absorbing yet instructive publication. You must be "in the know."

Partial Contents of the May Issue: When The HURRICANE Attacked; Plane Catapults; The "Ship-Wing" Fighter—Front Cover Feature; The Television Plane—Hugo Gernsback; New INVISIBLE Bomber—H. W. Secor; Whitley Bomber's New "Dustbins"; How Aircraft Carriers Work; How Airplane Engines are Started; New 2,000 H. P. Engine; Torpedo Planes in Action; R.A.F. Tactics.

attractive three-color cover, numerous illustrations. **15c** a copy

Send 10c for a Sample Copy.

Subscription price \$1.50 a Year, Canada and foreign \$2.00.

FLIGHT MAGAZINE, 20-R Vesey St., New York, N. Y.

GEOPHYSICAL PROSPECTING PRINTS

50¢ EACH
7 FOR \$3.—



With any one of the modern geophysical methods described, instruments can be constructed to locate metal and ore veins, subterranean water and oil deposits, buried pipes, tools, or other metallic objects sunken in water, etc. Folder contains blueprints and detailed data covering each instrument.

- Folder No. 1. Radiotelet Pilot. Construction and use of 2 tube transmitter and 3 tube receiver. Reflected wave principle. Visual and aural signals.
- Folder No. 2. Harmonic Frequency Locator. Radiates low frequency wave to receiver. Aural signals.
- Folder No. 3. Beat Note Indicator. 2 oscillators. Visual and aural signals.
- Folder No. 4. Radio Balance Surveyor. Balanced loop principle. Modulated transmitter. Visual and aural signals.
- Folder No. 5. Variable Inductance Monitor. Inductance principle. Aural signals.
- Folder No. 6. Hughes Inductance Balance Explorer. Bridge principle. Aural signals.
- Folder No. 7. RadioBme Prospector. Balanced loop principle. Very large field of penetration. Aural signals.

Each set of blueprints and instructions enclosed in heavy envelope (9 1/2" x 12 1/2"). Blueprints 22" x 34"; eight-page illustrated 8 1/2" x 11" folder of **50c** instructions and construction data. Add 5c for postage.

The complete set of seven folders **\$3.00**
Shipping weight 2 lbs. (add 25c for shipping anywhere in U.S.A.)

TECHNIFAX

1917 S. STATE ST. CHICAGO, ILL.

Where to Buy It! —

CLASSIFIED RADIO DIRECTORY

Handy Buying Guide, by Products and Manufacturers' Names and Addresses, for the Entire Radio Industry

There is no charge for regular light-face listings in the Classified Radio Directory. However, if dominant bold-face listings are desired, we make a charge of \$2 for concern names and \$1 for trade names for each bold-face listing. Please write to the Advertising Dept., Radio-Craft, 20 Vesey St., New York, N. Y., for details.

This DIRECTORY is published in sections—1 section per month. This method of publication permits the DIRECTORY to be constantly up-to-date since necessary revisions and corrections can be made monthly. All names preceded by an asterisk (*) indicate that they are trade names.

If you cannot find any item or manufacturer in this section or in previously-published sections, just drop us a line for the information.

Presented here in Section II of the completely revised Second Edition of the CLASSIFIED RADIO DIRECTORY.

While every precaution is taken to insure accuracy, Radio-Craft cannot guarantee against the possibility of occasional errors and omissions in the preparation of this Classified Directory. Manufacturers and readers are urged to report all errors and omissions at the earliest moment to insure corrections in the very next issue.

CRYSTALS (for detection—receiving) & DETECTORS



- Crystals (mounted) CM
- Crystals (unmounted) CU
- Detectors (fixed) D
- Detector stands DS

THE CARBORUNDUM COMPANY, Global Div., Niagara Falls, N. Y.—CU, D
MELOMITE COMPANY, % Allen Chevrolet Co., Clinton, Mo.—CM, CU, D, DS

DIALS & PARTS



- Complete dials CD
- Crystals & bezels CR
- Decalcomanias D
- Dial cables & cords DCC
- Dial lamps DL
- Dial-lamp sockets DS
- Dial pointers DP
- Escutcheons ES
- Faces or scales FS
- Faces or scales (machine engraved) FSM
- Handwheels H
- Knobs (molded) K
- Knobs (wood) KWD
- Knob springs KSP
- Nameplates NP
- Nameplates (machine engraved) NM
- Pilotlight assemblies PA
- Vernier drives V

*AIRLINE—Montgomery Ward & Co. ALDEN PRODUCTS CO., 715 Center St., Brockton, Mass.—K, PA
ALLIED RADIO CORP., 833 W. Jackson Blvd., Chicago, Ill.—*Knight—CD, DCC, DL, K, KWD, NP, PA
ALTO MANUFACTURING CO., 1647 Wolfram St., Chicago, Ill.—DP, ES
AMERICAN EMBLEM CO., INC., P. O. Box 116, Utica, N. Y.—CD, CR, DP, ES, FS, NP
AMERICAN PHENOLIC CORP., 1250 W. Van Buren St., Chicago, Ill.—CR
AMERICAN RADIO HARDWARE CO., INC., 476 Broadway, New York, N. Y.—CD, DCC, DL, DP, K, KSP, NP, PA
ANGELL MANUFACTURING CO., 1265 Broadway, New York, N. Y.—NP
AUBURN BUTTON WORKS, INC., Auburn, N. Y.—K
THE D. L. AULD COMPANY, 5th Ave. & 5th St., Columbus, Ohio—ES, NP
THE O. AUSTIN COMPANY, 42 Greene St., New York, N. Y.—D, FS, NP

BASTIAN BROS. CO., 1600 N. Clinton St., Rochester, N. Y.—CD, CR, ES, NP
BENDIX RADIO CORP., 920 E. Fort Ave., Baltimore, Md.—CR
*BIRNBACH—Birnbach Radio Co., Inc. BIRNBACH RADIO CO., INC., 145 Hudson St., New York, N. Y.—*Birnbach—DCC, K
BOND PRODUCTS CO., 13139 Hamilton Ave., Detroit, Mich.—CD
BROWNING LABORATORIES, INC., 750 Main St., Winchester, Mass.—CD
BUD RADIO, INC., 5205 Cedar Ave., Cleveland, Ohio—CD, DP, K, NP
*BULLS-I-UNITS—The H. R. Kirkland Co., Inc. CANADIAN MARCONI CO., 211 St. Sacramento St., Montreal, Can.—CD, DL, ES, FS, K, KWD, NP
CANADIAN RADIO CORP., LTD., 622 Fleet St., W., Toronto, Ont., Can.—DL, DP, K, KWD
CARLTON LAMP CORP., 730 S. 13th St., Newark, N. J.—DL
CHICAGO MOLDED PRODUCTS CORP., 1020 N. Kolmar Ave., Chicago, Ill.—K
CINCH MANUFACTURING CORP., 2335 W. Van Buren St., Chicago, Ill.—DS
CLAROSTAT MFG. CO., INC., 285 N. 6th St., Brooklyn, N. Y.—K
CONSOLIDATED WIRE & ASSOCIATED CORP., 512 S. Peoria St., Chicago, Ill.—K
CONTINENTAL-DIAMOND FIBRE CO., Newark, Del.—NP
CROWE NAME PLATE & MFG. CO., 3701 Ravenswood Ave., Chicago, Ill.—CD, CR, DCC, DP, ES, FS, K, NP, PA
CRUMPACKER DISTRIB. CORP., 1801 Fannin St., Houston, Tex.—CD, DL, DP, ES, FS, K, KWD, NP
THE DAVEN COMPANY, 158 Summit St., Newark, N. J.—ES, K
HAROLD DAVIS, INC., 428 W. Capital St., Jackson, Miss.—CD, CR, D, DL, DP, ES, FS, K, KWD, NP
DOW RADIO SUPPLY CO., 1759 E. Colorado, Pasadena, Calif.—CD, CR, DL, DP, ES, FS, K, KWD, NP
DRAKE MANUFACTURING CO., 1713 W. Hubbard St., Chicago, Ill.—PA
HUGH H. EBY, INC., 4700 Stanton Ave., Phila., Pa.—K
EMPIRE NOTION CO., 105 E. 29th St., New York, N. Y.—K, KWD
ERIE RESISTOR CORP., 644 W. 12th St., Erie, Pa.—DP, ES, K, NP
FEDERAL SCREW PRODUCTS CO., 24-26 S. Jefferson St., Chicago, Ill.—PA
FEDERATED PURCHASER, INC., 80 Park Place, New York, N. Y.—CD, CR, DCC, DL, DP, ES, K, KWD, NP, PA
FISCHER DISTRIB. CORP., 222 Fulton St., New York, N. Y.—CD, CR, D, DL, DP, ES, FS, K, KWD, NP
FLOCK PROCESS CORP., 17 W. 31st St., New York, N. Y.—CR, ES, FS
FONDA CORPORATION, 29 W. 57th St., New York, N. Y.—CD, ES, K, NP, PA
GEMLOID CORPORATION, 79-10 Albion Ave., Elmhurst, L. I., N. Y.—CDM, ESM, NP
GENERAL CEMENT MFG. CO., 919 Taylor Ave., Rockford, Ill.—DCC, K, KWD, KSP
GENERAL RADIO CO., 30 State St., Cambridge, Mass.—CD, K
GORDON SPECIALTIES CO., 1104 S. Wabash Ave., Chicago, Ill.—CD, DP, FS, K, NP, V
CARL GORR PRINTING CO., 2615 N. Ashland Ave., Chicago, Ill.—ES (paper)
L. F. GRAMMES & SONS, INC., 364 Union St., Allentown, Pa.—DP, ES, FS, NP
HARRISON RADIO CO., 12 W. Broadway, New York, N. Y.—CD, DL, K, NP
INSULINE CORP. OF AMERICA, 30-30 Northern Blvd., Long Island City, N. Y.—CD, CR, DP, ES, FS, KWD, NP
KAAR ENGINEERING CO., 619 Emerson St., Palo Alto, Calif.—F, S, M, NM

THE H. R. KIRKLAND CO., INC., 10 King St., Morristown, N. J.—*Bulls-I-Units—DL, PA
*KNIGHT—Allied Radio Corp.
KURZ-KASCH, INC., 1421 S. Broadway, Dayton, Ohio—K
LAFAYETTE RADIO CORP., 100 6th Ave., New York, N. Y.—CD, CR, DL, ES, K, KWD, NP
LEOTONE RADIO CO., 63 Dey St., New York, N. Y.—CD, FS
LIBERTY ENGRAVING & MFG. CO., 2911 S. Central Ave., Los Angeles, Calif.—CR, DP, ES, FS, NP
M & H SPORTING GOODS CO., 512 Market St., Phila., Pa.—CD, DL, K, KWD, NP
MAJESTIC RADIO & TELEVISION CORP., 2600 W. 50th St., Chicago, Ill.—CD, CR
P. R. MALLORY & CO., INC., 3029 E. Washington St., Indianapolis, Ind.—CL, K
MEISSNER MANUFACTURING CO., Mt. Carmel, Ill.—CD, ES, K
JAMES MILLEN MFG. CO., INC., 150 Exchange St., Malden, Mass.—CD, DL, DP, ES, FS, K, PA
J. W. MILLER CO., 5917 S. Main St., Los Angeles, Calif.—CD, DP, ES, FS, K
ELMER E. MILLS CORP., 812 W. Van Buren St., Chicago, Ill.—CR, DP, ES, FS, K, NP
MONTGOMERY WARD & CO., 619 W. Chicago Ave., Chicago, Ill.—*Airline—CD, DL, DP, ES, K, NP
NATIONAL COMPANY, INC., 61 Sherman St., Malden, Mass.—CD, CR, K
NATIONAL UNION RADIO CORP., 57 State St., Newark, N. J.—DL
OFFENBACH ELECTRIC CO., 1452 Market St., San Francisco, Calif.—CD, CR, DL, DP, ES, K, KWD, NP
PARISIAN NOVELTY CO., 3510 S. Western Ave., Chicago, Ill.—CD, CR, DP, FS, NP
PHILCO RADIO & TELEVISION CORP., Tioga & "C" Sts., Phila., Pa.—CD, D, DL, DP, ES, FS, K, KWD
PHILMORE MANUFACTURING CO., INC., 113 University Pl., New York, N. Y.—CR
RADIO ELECTRIC SERVICE CO., INC., N. W. Cor. 7th & Arch Sts., Phila., Pa.—CD, CR, D, DL, DP, ES, FS, K, KWD, NP
RADIO EQUIPMENT CORP., 326 Elm St., Buffalo, N. Y.—DL, DP, ES, FS, K, KWD, NP
RADOLEK COMPANY, 601 W. Randolph St., Chicago, Ill.—CD, DCC, DL, K, KWD, NP, PA
RCA MANUFACTURING CO., INC., Camden, N. J.—CD, CR, DP, ES, FS, K, KWD
THE RICHARDSON COMPANY, 27th & Lake Sts., Melrose Park, Ill.—ES, K
ROGERS-MAJESTIC CORP., LTD., 622 Fleet St., Toronto, Can.—CD, ES, K, KWD, NP
WALTER L. SCHOTT CO., 5266 W. Pico Blvd., Los Angeles, Calif.—*Walsco—DCC
MAURICE SCHWARTZ & SON, 710-712 Broadway, Schenectady, N. Y.—CD, CR, D, DL, DP, ES, FS, K, KWD, NP
SEATTLE RADIO SUPPLY CO., INC., 2117 2nd Ave., Seattle, Wash.—CD, CR, DCC, DL, ES, K, KWD, KSP, NP, PA
SHELLEY RADIO CO., 1841 S. Flower St., Los Angeles, Calif.—CR, DL, DP, ES, FS, K, KWD, NP
F. W. STEWART MFG. CORP., 340 W. Huron St., Chicago, Ill.—CD, DL, K, PA
SUN RADIO CO., 212 Fulton St., New York, N. Y.—CD, CR, DL, DP, ES, FS, K, KWD, NP
SYRACUSE ORNAMENTAL CO., Syracuse, N. Y.—ES, K, KWD
TRY-MO RADIO CO., INC., 85 Cortlandt St., New York, N. Y.—CD, CR, D, DCC, DL, DP, ES, FS, K, KWD, KSP, NP, PA
TUNG-SOL LAMP WORKS, INC., Radio Tube Div., 95 8th Ave., Newark, N. J.—DL
VICTORY MANUFACTURING CO., INC., 1217 Washington Blvd., Chicago, Ill.—K
*WALSCO—Walter L. Schott Co.
THE WATERBURY BUTTON CO., Waterbury, Conn.—ES, K
WESTINGHOUSE ELEC. & MFG. CO., E. Pittsburgh, Pa.—K

Please say you saw it in the Radio-Craft "Classified Radio Directory"

• CLASSIFIED RADIO DIRECTORY •

ELECTRIC FENCE CONTROLLERS



Condensers C
Units or kits UK

AEROVOX CORPORATION, New Bedford, Mass.—C
ALLIED RADIO CORP., 833 W. Jackson Blvd., Chicago, Ill., *Knight—UK
ARLAVOX MFG. CO., 430 S. Green St., Chicago, Ill.—UK
RADOLEK COMPANY, 601 W. Randolph St., Chicago, Ill.—UK
BOND PRODUCTS CO., 13139 Hamilton Ave., Detroit, Mich.—UK
CONTINENTAL ELECTRIC CO., Geneva, Ill.—UK
HARTMAN ELECTRICAL MFG. CO., 31 E. 5th St., Mansfield, Ohio—UK
*KNIGHT, Allied Radio Corp.
LAFAYETTE RADIO CORP., 100 6th Ave., New York, N. Y.—UK
SORENG-MANEGOLD CO., 1901 Clybourn Ave., Chicago, Ill.—UK
THORDARSON ELECTRIC MFG. CO., 500 W. Huron St., Chicago, Ill.—UK

ELECTRONIC EQUIPMENT



Capacity relays CR
Exciter lamps EL
High-frequency generators (heat-treating, brazing, soldering, etc.) HG
Lens systems LS
Micrometers MI
Mirrors M
Photocell amplifiers PA
Photocell multipliers PM
Photocells (chemical) PC
Photocells (oxide) PO
Photocells (selenium) PS
Photocells (vacuum) PV
Power rectifiers PR
Power supplies P
Power supplies, vibrator PSV
Remote controls R
Robot electronic controls (alarms, level controls, etc.) RC
Stethophones (electric) S
Timers (photo) T
Vibration pickups (microphones) PI
"Wireless" detective devices W
Wire-tapping devices WD

*AC, National Company, Inc.
ADVANCE ELECTRIC CO., 1260 W. 2nd St., Los Angeles, Calif.—R
ALLIED ENGINEERING INSTITUTE, 85 Warren St., New York, N. Y.—R, RC, W
ALLIED RADIO CORP., 833 W. Jackson Blvd., Chicago, Ill., *Knight—CR, M, PA, PC, PS, P, RC
AMERICAN TELEVISION & RADIO CO., 300 E. 4th St., St. Paul, Minn.—PR, PSV
AMPLIFIER CO. OF AMERICA, 17 W. 20th St., New York, N. Y.—CR, PA, PSV, PR, P, R
*BELL & HOWELL, Bell & Howell Co.
BELL & HOWELL CO., 1801 Larchmont Ave., Chicago, Ill., *Filmo, *Filmosound, *Eyemo, *Bell & Howell—LS
CANADIAN MARCONI CO., 211 St. Sacrament St., Montreal, Can.—PR, P, PSV
THE BENWOOD-LINZE CO., 1838 Washington Ave., St. Louis, Mo.—P
CINEMA ENGINEERING CO., 1508 W. Verdugo Ave., Burbank, Calif.—PR, P, PSV, R
*CLARION, Transformer Corp. of America, COMMUNICATIONS, INC., 3215 Western Ave., Seattle, Wash., *Commun-O-Phone, *Incriminator, *Electro-Phone—PA, PSV, R, RC, WD
*COMMUN-O-PHONE, Communications, Inc.
CONTINENTAL ELECTRIC CO., Geneva, Ill.—PO, PV
CRUMPACKER DISTRIB. CORP., 1801 Fannin St., Houston, Tex.—EL, PA, PV, R
DeVRY CORPORATION, 1111 Armitage Ave., Chicago, Ill.—EL, LS, PA, PS, P
*DICTAFILM, Miles Reproducer Co., Inc.
HUGH H. EBY, INC., 4700 Stenton Ave., Phila., Pa.—PS
E. A. ECKSTEIN CO., LeRoy, Minn.—PA

ELECTRONIC CONTROL CORP., 2667 E. Grand Blvd., Detroit, Mich.—CR, LS, M, PA, PS, P, R, RC
ELECTRONIC PRODUCTS CO., St. Charles, Ill.—PA
*ELECTRO-PHONE, Communications, Inc.
*EYEMO, Bell & Howell Co.
FARNSWORTH TELEVISION & RADIO CORP., 3700 E. Pontiac St., Ft. Wayne, Ind.—CR, EL, PA, PM, PS, PV
FEDERAL TELEGRAPH CO., 200 Mt. Pleasant Ave., Newark, N. J.—PR
FEDERATED PURCHASER, INC., 80 Park Pl., New York, N. Y.—EL, PS, PV, PSV
*FILMGRAPH, Miles Reproducer Co., Inc.
*FILMO, Bell & Howell Co.
*FILMOSOUND—Bell & Howell Co.
FINCH TELECOMMUNICATIONS, INC., 1819 Broadway, New York, N. Y.—LS, PA, P
FISCHER DISTRIB. CORP., 222 Fulton St., New York, N. Y.—CR, EL, PA, PS, PV, RC
FISCHER-SMITH, INC., 162 State St., W. Englewood, N. J.—CR, PA, R, RC
GENERAL ELECTRIC CO., Schenectady, N. Y. & Bridgeport, Conn.—EL, PA, PS, PV, PR, R
G-M LABORATORIES, INC., 4326 N. Knox Ave., Chicago, Ill.—PO, PS, PV
GUARDIAN ELEC. MFG. CO., 1621 W. Walnut St., Chicago, Ill.—CR, R, RC
HAMMOND MFG. CO., 40 Wellington St. W., Guelph, Ont., Canada—P
HARRISON RADIO CO., 12 W. Broadway, New York, N. Y.—CR, LS, M, PA, PM, PC, PO, PS, PV, PR, P, PSV, R, RC
HARVEY-WELLS COMMUNICATIONS, INC., North St., Southbridge, Mass.—PA, R
*INCRIMINATOR, Communications, Inc.
INTERNATIONAL TRANSFORMER CO., 17 W. 20th St., New York, N. Y.—PR, P, PSV
CHARLES JACK MFG. CORP., 420-22 Lehigh St., Allentown, Pa.—P, R
KAAR ENGINEERING CO., 619 Emerson St., Palo Alto, Calif.—PSV
*KNIGHT, Allied Radio Corp.
LAFAYETTE RADIO CORP., 100 6th Ave., New York, N. Y.—CR, EL, LS, M, PA, PC, PS, P, R, RC
LEKTRA LABORATORIES, INC., 30 E. 10th St., New York, N. Y.—T
THE LINCROPHONE CO., INC., 1661 Howard Ave., Utica, N. Y.—PA
LUMENITE ELECTRIC CO., 407 S. Dearborn St., Chicago, Ill.—CR, PA, PM, R, RC, T
T. R. McLEROY, 100 Brookline Ave., Boston, Mass.—EL, PA, PC, PO, PS, PV
P. R. MALLORY & CO., INC., 3029 E. Washington St., Indianapolis, Ind.—P (battery-operated)
MELLOPHONE CORPORATION, 65 Atlantic Ave., Rochester, N. Y.—EL, PA, PC, PR, P
MILES REPRODUCER CO., INC., 812 Broadway, New York, N. Y., *Filmmograph, *Dictafilm—PA, PR, R
MUSIC MASTER MFG. CO., 508 S. Dearborn St., Chicago, Ill.—PA, P
NATIONAL COMPANY, INC., 61 Sherman St., Malden, Mass., *National, *AC—P, PSV
*NATIONAL, National Company, Inc.
NATIONAL UNION RADIO CORP., 57 State St., Newark, N. J.—EL, PS
NORTHERN ELECTRIC CO., LTD., 1261 Shearer St., Montreal, Que., Can.—PA, PC, PO, PS, PV, P, R
OFFENBACH ELECTRIC CO., 1452 Market St., San Francisco, Calif.—PC, PO, PS, PV
OPERADIO MANUFACTURING CO., St. Charles, Ill.—PA
OHIO CRANKSHAFT CO., TOCCO DIV., 6600 Clement Ave., Cleveland, Ohio—HG
PHILCO RADIO & TELEVISION CORP., Tioga & "C" Sts., Phila., Pa.—PS
PHONOTONE LABORATORIES, INC., S. E. 15th & State Sts., Washington, Ind.—LS, M, PA, R
PHOTOBELL CORPORATION, 123 Liberty St., New York, N. Y.—CR, LS, M, PA, PO, PS, PV, P, R, RC
PHOTOSWITCH, INC., 21 Chestnut St., Cambridge, Mass.—CR, LS, M, PA, PV, P, R
RADIO ELECTRIC SERVICE CO., INC., N.W. Cor. 7th & Arch Sts., Phila., Pa.—CR, EL
RADIO EQUIPMENT CORP., 326 Elm St., Buffalo, N. Y.—CR
RADOLEK COMPANY, 601 W. Randolph St., Chicago, Ill.—EL, PA, PS
RAYTHEON MFG. CO., 190 Willow St., Waltham, Mass.—PR
RCA MANUFACTURING CO., INC., Camden, N. J.—EL, PA, PS, PV, P, RC
REGAL AMPLIFIER MFG. CORP., 14 W. 17th St., New York, N. Y.—WD
ROWE RADIO RESEARCH LAB. CO., 4201 Irving Park Blvd., Chicago, Ill.—PA, P, R, RC
MAURICE SCHWARTZ & SON, 710-712 Broadway, Schenectady, N. Y.—CR, EL, LS, M, PA, PC, PO, PS, PV, P, R, RC
SEATTLE RADIO SUPPLY CO., INC., 2117 2nd Ave., Seattle, Wash.—PA, PS, PV, PR, PSV
SHURE BROTHERS, 225 W. Huron St., Chicago, Ill., *Shure, *Unidyne, *Uniplex, *Rocket, *Stratoliner, *Super-Level, *Ultra-Wide Range, *Zephyr—S
S.O.S. CINEMA SUPPLY CORP., 636 11th Ave., New York, N. Y.—EL, LS, M, PA, PO, PV, P
STARK ELECTRICAL INSTRUMENT CO., 161A King St., W. Toronto, Ont., Can.—MI
SUN RADIO CO., 212 Fulton St., New York, N. Y.—CR, EL, PS, R, RC
TAY BERN EQUIPMENT CO., INC., 135 Liberty St., New York, N. Y.—RC

THORDARSON ELECTRIC MFG. CO., 500 W. Huron St., Chicago, Ill.—P
TIBBETTS LABORATORIES, Camden, Maine, *Monobar—PI
TRANSFORMER CORP. OF AMERICA, 69 Wooster St., New York, N. Y., *Clarion—PA, PR, P, PSV, R
UNITED CINEPHONE CORP., Torrington, Conn.—CR, PA
VICTOR ANIMATOGRAPH CORP., Davenport, Iowa—EL, PS (for sound projection)
WESTERN SOUND & ELECTRIC LABS., INC., 311 N. Kilbourn Ave., Milwaukee, Wis.—PA, P, PSV, R
WESTINGHOUSE ELEC. & MFG. CO., E. Pittsburgh, Pa.—HG, PS, PV, PR
WHEELCO INSTRUMENTS CO., 1933 S. Halsted St., Chicago, Ill.—CR, PA, PV, PSV, R
WILCOX ELECTRIC CO., INC., 40th & State Line, Kansas City, Mo.—P, PSV
WORNER PRODUCTS CORP., 1019 W. Lake St., Chicago, Ill.—M, PA, PV, RC
WEBSTER ELECTRIC CO., Clark & DeKoven Ave., Racine, Wis.—R, RC

ELECTRONIC MUSICAL INSTRUMENTS & PARTS



Contact microphones CM
Electronic organs EO
Electronic percussion instruments (chimes, etc.) EC
Electronic pianos EP
Electronic reed instruments ER
Electronic string instruments ES
Harmonicas H
"Musical amplifiers" (music-instrument type amplifiers) MA
Organ adapter OA
Pedal volume controls PV

*AIRLINE, Montgomery Ward & Co., Inc.
ALLIED ENGINEERING INSTITUTE, 85 Warren St., New York, N. Y.—CM, MA
ALLIED RADIO CORP., 833 W. Jackson Blvd., Chicago, Ill., *Knight—CM, EC, MA, PV
ALOHA MUSICAL INSTRUMENT & PUBLISHING CO., 807 W. 79th St., Chicago, Ill.—CM, ES, MA, PV
AMPERITE COMPANY, 561 Broadway, New York, N. Y.—CM, PV
AMPLIFIER CO. OF AMERICA, 17 W. 20th St., New York, N. Y.—EC, MA
ANSLEY RADIO CORP., 4377 Bronx Blvd., New York, N. Y., *Dynaphone, *Dynamone—EP
THE BRUSH DEVELOPMENT CO., 3311 Perkins Ave., Cleveland, Ohio—CM
CINEMA ENGINEERING CO., 1508 W. Verdugo Ave., Burbank, Calif.—PV
*CLARION, Transformer Corp. of America, COMMUNICATIONS, INC., 3215 Western Ave., Seattle, Wash., *Commun-O-Phone, *Incriminator, *Electro-Phone—EO, P, ER, MA
*COMMUN-O-PHONE, Communications, Inc.
*CO-RECHT, Electronic Sound & Music Co.
CRACRAFT, INC., 28 Grove St., New York, N. Y.—CM, PV, EP, ES
CRUMPACKER DISTRIB. CORP., 1801 Fannin St., Houston, Tex.—CM
DAVITT & HAUSER, 304 Main St., Cincinnati, Ohio—ES
*DYNAPHONE, Ansley Radio Corp.
*DYNATONE, Ansley Radio Corp.
ELECTRONIC SOUND & MUSIC CO., 10 Stuyvesant St., New York, N. Y., *Co-Recht—EC, EO, ER, ES, MA
*ELECTRO-PHONE, Communications, Inc.
EPIPHONE, INC., 142 W. 14th St., New York, N. Y.—CM, ES, MA, PV
EVERETT PIANO CO., South Haven, Mich.—EO, EP
EVER-NU PRODUCTS, 919 N. Latrobe Ave., Chicago, Ill.—CM
FEDERATED PURCHASER, INC., 80 Park Pl., New York, N. Y.—CM, MA, PV
FISCHER DISTRIBUTING CORP., 222 Fulton St., New York, N. Y.—CM
FONDA CORPORATION, 29 W. 57th St., New York, N. Y.—CM, PV
FRETTED INSTRUMENT MANUFACTURERS, INC., 127 S. 15th St., Newark, N. J.—ES
GIBSON, INC., 219 Parsons St., Kalamazoo, Mich.—ES
GULBRANSEN COMPANY, 816 N. Kedzie Ave., Chicago, Ill.—EO
HAMMOND INSTRUMENT CO., 2915 N. Western Ave., Chicago, Ill.—EO, EP, OA
HARDMAN PECK & CO., 33 W. 57th St., New York, N. Y.—EP
HARMONY COMPANY, 1742 N. Lawndale Ave., Chicago, Ill.—ES
HARPTONE MANUFACTURING CORP., 127 S. 15th St., Newark, N. J.—ES, MA
HARRISON RADIO CO., 12 W. Broadway, New York, N. Y.—CM

Please say you saw it in the Radio-Craft "Classified Radio Directory"

SERVICEMEN SAY:—For Bigger Profits— For Better Servicing—USE GERNSBACK MANUALS

Since 1931 more and more Servicemen have been buying GERNSBACK OFFICIAL RADIO SERVICE MANUALS year after year. The authentic material, easily accessible diagrams and complete service data make them invaluable to dealers and radio Servicemen. Without a Gernsback Manual with you on a repair job, there's time and profit lost. Your service kit or laboratory is incomplete without all the GERNSBACK OFFICIAL RADIO SERVICE MANUALS. There are GERNSBACK MANUALS also for servicing auto-radios, refrigeration and air conditioning equipment.



VOLUME 7 OFFICIAL RADIO SERVICE MANUAL

The newest and most outstanding GERNSBACK Manual published since 1931. Contains many features never previously published in any service guide. ● OVER 1,800 PAGES ● OVER 3,000 ILLUSTRATIONS ● OVER 1,600 SETS REPRESENTED ● Complete Service Data ● Includes 1938 Models Not Found in Other Manuals ● All New Material—No Reprint or Rehash ● Master Index of 74 Pages Includes Sets Listed in All Other Gernsback Manuals ● Stiff, Leatherette Looseleaf Covers ● Size 9 x 12 Inches ● Net Weight 10 1/2 lbs.

Price \$10.00



1935 OFFICIAL AUTO-RADIO SERVICE MANUAL

If you are overlooking servicing auto radios, then you are missing a great deal of business. The great number of car radios in use require constant servicing and you can make it a profitable sideline to your regular servicing business. This complete Manual contains schematic diagrams,

chassis layouts, mounting instructions and trouble shooting hints. ● OVER 240 PAGES ● OVER 500 ILLUSTRATIONS ● Flexible, Leatherette Looseleaf Covers ● Size 9 x 12 Inches ● Net Weight 1 1/4 lbs.

Price \$2.50

1936 OFFICIAL RADIO SERVICE MANUAL

Just packed with service data of sets manufactured during 1935 and 1936. Schematic diagrams show speaker connections, power-transformer connections, R.F. and I.F. coil connections, phonograph connections and other information. ● OVER 1,200 PAGES ● OVER 1,500 SETS SHOWN ● OVER 2,500 ILLUSTRATIONS ● Index of Trade Names ● Complete Tube Chart ● Stiff, Leatherette, Looseleaf Covers ● Size 9 x 12 Inches ● Net Weight 8 lbs.

Price \$7.00

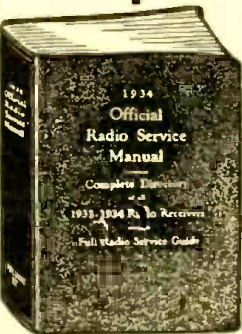

1934 OFFICIAL RADIO SERVICE MANUAL

This manual contains values of I.F. transformers on superheterodyne receivers, valuable tube data, complete list of American broadcast stations, free question and answer service, service material and schematic diagrams. ● OVER 400 PAGES ● OVER 2,000 ILLUSTRATIONS ● Flexible, Leatherette, Looseleaf Covers ● Size 9 x 12 Inches ● Net Weight 2 1/4 lbs.

Price \$3.50



OFFICIAL REFRIGERATION SERVICE MANUAL

Volume 2

This is the only complete refrigeration service manual ever published. Contains detailed information on servicing, outlines of theory and methods of operation, instructions for the handling of refrigerants, charging systems, diagnosing troubles, charts, electrical hook-ups and a wealth of other necessary data. ● OVER 352 PAGES ● OVER 300 DIAGRAMS ● Flexible, Leatherette, Looseleaf Covers ● Size 9 x 12 Inches ● Net Weight 1 1/2 lbs.

Price \$5.00

1932 OFFICIAL RADIO SERVICE MANUAL

Here is the volume which shows a step-by-step analysis of how to service any receiver. It is one of the early editions and covers many old sets, thousands of which are still in use throughout the country. ● OVER 1,000 PAGES ● OVER 2,000 ILLUSTRATIONS ● Flexible, Leatherette, Looseleaf Covers ● Size 9 x 12 Inches ● Net Weight 4 1/2 lbs.

Price \$5.00



OFFICIAL AIR CONDITIONING SERVICE MANUAL

This manual is edited by L. K. Wright, who is an expert and leading authority on air conditioning and refrigeration. Nearly every page is illustrated, every modern installation and individual part carefully explained, diagrams furnished of all known equipment, special care given to the servicing and installation end. Necessary tools are illustrated and explained, etc. ● OVER 352 PAGES ● OVER 600 ILLUSTRATIONS ● Flexible, Leatherette, Looseleaf Covers ● Size 9 x 12 Inches ● Net Weight 2 1/4 lbs.

Price \$5.00



RADCRAFT PUBLICATIONS, Inc., 20 VESEY ST., NEW YORK, N. Y.

Gentlemen: Enclosed find my remittance of \$..... for which send me, POSTPAID, the Manuals indicated below by a cross (x) in the panel.

- () Volume 7 @ \$10.00 () 1936 Manual @ \$7.00 () 1934 Manual @ \$3.50
 () 1935 Auto-Manual @ \$2.50 () 1932 Manual @ \$5.00
 () Refrigeration Manual (Vol. 2) @ \$5.00 () Air Conditioning Manual @ \$5.00

Name Address

City State

(Send remittance in form of check or money order; register your letter if you send cash or unused U. S. Postage Stamps.)

RC-541

To order these famous Manuals, see or write to your jobber or favorite mail order house. If more convenient, mail coupon directly to publishers.

RADCRAFT PUBLICATIONS, Inc.
 20 VESEY STREET NEW YORK, N. Y.

RADIO-CRAFT for MAY, 1941

CLASSIFIED RADIO DIRECTORY

FRANK HOGAN COMPANY, Elkhorn, Wis.—EP
 *INCRIMINATOR, Communications, Inc.
 CHARLES JACK MFG. CORP., 420-22 Lehigh St.,
 Allentown, Pa.—EC EO
 KAY MUSICAL INSTRUMENT CO., 1640 Walnut St.,
 Chicago, Ill.—ES, MA
 *KNIGHT, Allied Radio Corp.
 KRAKAUER BROTHERS, 115 W. 57th St., New York,
 N. Y.—EP
 LAFAYETTE RADIO CORP., 100 6th Ave., New
 York, N. Y.—CM, PV
 LEOTONE RADIO CO., 63 Dey St., New York, N. Y.
 —CM
 MAAS ORGAN CO., 3015 Casitas Ave., Los Angeles,
 Calif.—EC
 MASON & RASCH, LTD., 642 King St., W., Toronto
 2, Ont., Can.—EP
 JOHN MECK INDUSTRIES, 1313 Randolph, Chi-
 cago, Ill.—CM, ES, MA
 MIESSNER INVENTIONS, INC., 18 Main St., Mill-
 burn, N. J.—EO, EC, EP, ER, ES, PV
 MILLION RADIO & TELEVISION, 1617 N. Damen
 Ave., Chicago, Ill.—MA
 *MONOBAR—Tibbetts Laboratories
 MONTGOMERY WARD & CO., INC., 619 W. Chi-
 cago Ave., Chicago, Ill., *Airline—CM
 MUSIC MASTER MFG. CO., 508 S. Dearborn St.,
 Chicago, Ill.—MA
 NATIONAL DOBRO CORP., 400 S. Peoria St., Chi-
 cago, Ill.—PV, ES
 NORTHERN ELECTRIC CO., 1261 Shearer St.,
 Montreal, Que., Can.—CM, EO EP
 OFFENBACH ELECTRIC CO., 1452 Market St., San
 Francisco, Calif.—CM
 OPERADIO MANUFACTURING CO., St. Charles,
 Ill.—MA
 PACENT ENGINEERING CORP., 79 Madison Ave.,
 New York, N. Y.—MA
 PHONOTONE LABORATORIES, INC., S. E. 15th &
 State Sts., Washington, Ind.—MA
RADIO ELECTRIC SERVICE CO., INC., N.W.
 Cor. 7th & Arch Sts., Phila., Pa.—CM, PV
 RADIO EQUIPMENT CORP., 326 Elm St., Buffalo,
 N. Y.—CM, PV
 RADOLEK COMPANY, 601 W. Randolph St., Chi-
 cago, Ill.—CM, MA
 RCA MANUFACTURING CO., INC., Camden,
 N. J.—EC, EP, ER
 REGAL AMPLIFIER, 14 W. 17th St., New York, N. Y.
 —MA
 ROWE INDUSTRIES, INC., 3120 Monroe St., Toledo,
 Ohio—CM, PV, ES
 FRANCIS J. RYBAK & CO., 4131 White Plains Rd.,
 Bronx, N. Y.—EC
 SEATTLE RADIO SUPPLY CO., INC., 2117 2nd Ave.,
 Seattle, Wash.—CM
 OSCAR SCHMIDT INTERNATIONAL, INC., 87
 Ferry St., Jersey City, N. J.—ES
 MAURICE SCHWARTZ & SON, 710-712 Broadway,
 Schenectady, N. Y.—CM, EO, EP, ER, ES, H, PV
 MARK SIMPSON DISTRIBUTING CO., INC., 16
 Hudson St., New York, N. Y.—CM, PV
 SHERLOCK MANNING CO., Clinton, Ont., Can.
 —EO
 SLINGERLAND BANJO & DRUM CO., 1325 W.
 Belden Ave., Chicago, Ill.—ES
SOUND PROJECTS CO., 3140 W. Walton St.,
 Chicago, Ill.—EC, ES
 STORY & CLARK PIANO CO., 64 E. Jackson Blvd.,
 Chicago, Ill.—EP
SUNDT ENGINEERING CO., 4757 Ravens-
 wood Ave., Chicago, Ill.—EC, MA
 SUN RADIO CO., 212 Fulton St., New York, N. Y.
 —CM, PV
 TIBBETTS LABORATORIES, Camden, Maine, *Mon-
 obar—CM
 TRANSFORMER CORP. OF AMERICA, 69 Wooster
 St., New York, N. Y., *Clarion—MA
 THE TURNER CO., 909 17th St., Cedar Rapids, Iowa
 —CM
 THE VEGA COMPANY, 155 Columbus Ave., Boston,
 Mass., *Vega, *Vitor—CM, ES, MA, PV
 *VEGA, The Vega Company
 *VITAR, The Vega Company
 VIVI TONE COMPANY, 6321 Gratiot Ave., Detroit,
 Mich.—EO, EP, ER, ES, MA, PV
 THE VOLU-TONE COMPANY, 252 S. Broadway, Los
 Angeles, Calif.—CM, ES, MA
 WESTERN SOUND & ELECTRIC LABS., INC., 311 W.
 Kilbourn Ave., Milwaukee, Wis.—MA
 WESTERN STATES WHOLESALE MUSIC CORP.,
 4333 Brooklyn, Seattle, Wash.—ES

FACSIMILE



Kits K
 Receivers R
 Transmitters T

AMERICAN RADIO HARDWARE CO., INC., 476
 Broadway, New York, N. Y.—K
 J. H. BUNNELL & CO., 215 Fulton St., New York,
 N. Y.—R, T
 RCA MANUFACTURING CO., INC., Camden,
 N. J.—R, T

FINCH TELECOMMUNICATIONS, INC., 1819
 Broadway, New York, N. Y.—R, T
 FONDA CORPORATION, 29 W. 57th St., New York,
 N. Y.—R
 RADOLEK COMPANY, 601 W. Randolph St., Chi-
 cago, Ill.—K, R
 WILCOX ELECTRIC CO., INC., 40th & State Line,
 Kansas City, Mo.—K, R, T

FLUORESCENT & NEON LAMPS (& EQUIPMENT)



Ballasts (lamp and/or line) B
 Fixtures F
 Flashers (6 V.) for neon tubes FL
 Lamp holders LH
 Lamps L
 Power factor condensers PC
 Power packs (6 V. to high voltage)
 for neon tubes PP
 Starters S
 Starting compensators SC
 Switch controls SW

ART SPECIALTY CO., 1115 N. Franklin St., Chicago,
 Ill.—B, F, FL, LH, L, PP, S, SC, SW
 *ATOMS, Sprague Products Co.
 CHICAGO TRANSFORMER CORP., 3501 Addison
 St., Chicago, Ill.—B
 GENERAL TRANSFORMER CORP., 1250 W. Van
 Buren St., Chicago, Ill.—B, F, FL, LH, L, PP, S,
 SC, SW
 *KOOLOHMS, Sprague Products Co.
 RCA MANUFACTURING CO., INC., Camden,
 N. J.—R, T
 *600 LINE, Sprague Products Co.
 *SMITHCRAFT, A. L. Smith Iron Co.
 A. L. SMITH IRON CO., 217 Everett Ave., Chelsea,
 Mass., *Smithcraft—F
 SPRAGUE PRODUCTS CO., N. Adams, Mass., *600
 Line—*Atoms, *Koolohms, *Telohmike—PC
 *TELOHMIKE, Sprague Products Co.

FREQUENCY MODULATION EQUIPMENT



Adapters, add-on A
 Antennas (receiving) AR
 Antennas (transmitting) AT
 Cable C
 Coils CO
 Combination A.M.-F.M. adapters CA
 Combination A.M.-F.M. receivers CR
 Dials D
 F.M. amplifiers (audio) FA
 F.M. signal generators FG
 Lead-ins L
 Police, emergency services, utility P
 Receivers R
 Test apparatus (see Test Equipment)
 Transmitters T

*AC, National Company, Inc.
 ALLIED RADIO CORP., 833 W. Jackson Blvd., Chi-
 cago, Ill., *Knight—A, AR, CO, CA, CR, FG, R
 ALPHA WIRE CORP., 50 Howard St., New York,
 N. Y.—C, L
 AMERICAN COMMUNICATIONS CORP., 123 Lib-
 erty St., New York, N. Y.—AR, AT, T
 AMERICAN EMBLEM CO., INC., P. O. Box 116,
 Utica, N. Y.—D
 AMERICAN PHENOLIC CORP., 1250 W. Van Buren
 St., Chicago, Ill.—C, L
 AMERICAN RADIO HARDWARE CO., INC., 476
 Broadway, New York, N. Y.—D
 AMPLIFIER CO. OF AMERICA, 17 W. 20th St., New
 York, N. Y.—FA
 VICTOR J. ANDREW CO., 6429 S. Laverne Ave.,
 Chicago, Ill.—C (coaxial)
 ANSLEY RADIO CORP., 4377 Bronx Blvd., New
 York, N. Y., *Dynaphone, *Dynatone—CA
 *ANTENNEX, M. M. Fleron & Son, Inc.
 BARBER & HOWARD, INC., East Ave., Westerly,
 R. I.—CO
 BARKER & WILLIAMSON, Ardmore, Pa.—T
BELDEN MANUFACTURING CO., 4647 W.
 Van Buren St., Chicago, Ill.—AR, AT
 *BIRNBACH, Birnbach Radio Co., Inc.

BIRNBACH RADIO CO., INC., 145 Hudson St.,
 New York, N. Y., *Birnbach—AR, AT, C, D, R
 BOND PRODUCTS CO., 13139 Hamilton Ave., De-
 troit, Mich.—R
L. S. BRACH MFG. CORP., 55 Dickerson St.,
 Newark, N. J.—AR, AT
 BROWNING LABORATORIES, INC., 750 Main St.,
 Winchester, Mass.—A, CO, D, R
 CANADIAN MARCONI CO., 211 St. Sacramento
 St., Montreal, Can.—A, AR, AT, CO, CA, CR, P,
 R, T
 CARRON MANUFACTURING CO., 415 S. Aber-
 deen St., Chicago, Ill.—CO, FA, R
 THE CLOUGH-BREngle CO., 5501 Broadway,
 Chicago, Ill.—FG
 CONSOLIDATED WIRE & ASSOCIATED CORPS.,
 512 S. Peoria St., Chicago, Ill.—AR
 CORNISH WIRE CO., INC., 15 Park Row, New
 York, N. Y.—AR, AT, C, L
 THE CROSLY CORPORATION, Cincinnati, Ohio
 —R
 CROWE NAME PLATE & MFG. CO., 3701 Ravens-
 wood Ave., Chicago, Ill.—D
 HAROLD DAVIS, INC., 428 W. Capitol St., Jack-
 son, Miss.—A
 DELTA RADIO CORP., 115 Worth St., New York,
 N. Y.—CO
 DOOLITTLE RADIO, INC., 7421 Loomis Blvd., Chi-
 cago, Ill.—P, R, T
 DOW RADIO SUPPLY CO., 1759 E. Colorado St.,
 Pasadena, Calif.—A, AR, AT, CO, D, R, T
 *DYNAPHONE, Ansley Radio Corp.
 *DYNATONE, Ansley Radio Corp.
 ESPEY MFG. CO., INC., 305 E. 63rd St., New York,
 N. Y.—A, CA, CR, K
 FARNSWORTH TELEVISION & RADIO CORP., 3700
 E. Pontiac St., Fort Wayne, Ind.—FA
 FISCHER DISTRIB. CORP., 222 Fulton St., New
 York, N. Y.—A, AR, AT, CO, CA, CR, D, R, T
 FISHER RESEARCH LABORATORY, 1961 University
 Ave., Palo Alto, Calif.—P, R, T
 *FLERON, M. M. Fleron & Son, Inc.
 M. M. FLERON & SON, INC., 113 N. Broad St.,
 Trenton, N. J., *Antennex, *Fleron, *Safestest,
 *Signaler—AR
 FREED RADIO CORP., 39 W. 19th St., New York,
 N. Y.—CR
 GALVIN MANUFACTURING CORP., 45-45 W.
 Augusta Blvd., Chicago, Ill., *Motorola—P
 GENERAL ELECTRIC CO., Schenectady, N. Y. &
 Bridgeport, Conn.—A, AR, AT, C, CR, FA (for
 station), P, R, T
 GENERAL RADIO CO., 30 State St., Cambridge,
 Mass.—FG
 EDWIN I. GUTHMAN & CO., INC., 400 S. Peoria
 St., Chicago, Ill.—CO
 D. H. HARRELL, 1527 E. 74th Pl., Chicago, Ill.—AR,
 AT
 HARRISON RADIO CO., 12 W. Broadway, New
 York, N. Y.—A, AR, AT, C, CO, CR, FA, L, R
 HARVEY-WELLS COMMUNICATIONS, INC., North
 St., Southbridge, Mass.—AR, AT, C, L, P, R, T
 INSULINE CORP. OF AMERICA, 30-30 Northern
 Blvd., Long Island City, N. Y.—AR
 J. F. D. MANUFACTURING CO., 4111 Ft. Hamilton
 Pkway, Brooklyn, N. Y.—AR
 E. F. JOHNSON COMPANY, Maseca, Minn.—AR,
 AT
 *KNIGHT, Allied Radio Corp.
 KURZ-KASCH, INC., 1421 S. Broadway, Dayton,
 Ohio—D
 LAFAYETTE RADIO CORP., 100 6th Ave., New York,
 N. Y.—A, AR
 JOHN E. LINGO & SON, INC., 2nd St. & Buren
 Ave., Camden, N. J.—AT
 FRED M. LINK, 125 W. 17th St., New York, N. Y.—P
 MAC-ADAMS EQUIPMENT CO., INC., 507 W.
 56th St., New York, N. Y.—AR, CR
 MAJESTIC RADIO & TELEVISION CORP., 2600 W.
 50th St., Chicago, Ill.—CO, CA, CR, R
 MARINE RADIO CORP., 117-19 168th St., Jamaica,
 N. Y.—R, T
 MIESSNER MANUFACTURING CO., Mt. Carmel,
 Ill.—A, CO, CA, CR, D, R
 JAMES MILLEN MFG. CO., INC., 150 Exchange St.,
 Malden, Mass.—CO
 J. W. MILLER CO., 5917 S. Main St., Los Angeles,
 Calif., *Miller Quality Products, *Miller—CO
 *MILLER, J. W. Miller Co.
 *MILLER QUALITY PRODUCTS, J. W. Miller Co.
 MILLION RADIO & TELEVISION, 1617 N. Damen
 Ave., Chicago, Ill.—FG
 MIMS RADIO CO., P. O. Box 504, Texarkana, Ark.
 —AR, AT
 MISSION BELL RADIO MFG. CO., INC., 831
 Venice Blvd., Los Angeles, Calif.—R
 *MOTOROLA, Galvin Manufacturing Corp.
 NATIONAL COMPANY, INC., 61 Sherman St.,
 Malden, Mass., *National, *AC—CO, FA, R
 *NATIONAL, National Company, Inc.
 NORTHERN ELECTRIC CO., LTD., 1261 Shear-
 es St., Montreal, Que., Can.—T
 OFFENBACH ELECTRIC CO., 1452 Market St., San
 Francisco, Calif.—AR, D, R, T
 PACENT ENGINEERING CORP., 79 Madison Ave.,
 New York, N. Y.—A, CR, FA, R
 RADEX CORPORATION, 1733 Milwaukee Ave., Chi-
 cago, Ill.—CO
RADIO ELECTRIC SERVICE CO., INC., N.W.
 Cor. 7th & Arch Sts., Phila., Pa.—A, AR,
 AT, CO, CA, CR, D, R, T

Please say you saw it in the Radio-Craft "Classified Radio Directory"

• CLASSIFIED RADIO DIRECTORY •

RADIO ENGINEERING LABS., INC., 35-54 36th St., Long Island City, N. Y.—AT, P, R, T
 RADIO RECEPTOR CO., INC., 251 W. 19th St., New York, N. Y.—AT
 RADOLEK COMPANY, 601 W. Randolph St., Chicago, Ill.—AR, C, CO, CA, CR, L, R
 RCA MANUFACTURING CO., INC., Camden, N. J.—AR, AT, CR, R, T
 *SAFEST, M. M. Fleron & Son, Inc.
 MAURICE SCHWARTZ & SON, 710-712 Broadway, Schenectady, N. Y.—A, AR, AT, CO, CA, CR, D, R, T
 SEATTLE RADIO SUPPLY CO., INC., 2117 2nd Ave., Seattle, Wash.—AR, AT, C, CO, CR, L, P, R
 SETCHELL CARLSON, INC., 2233 University Ave., St. Paul, Minn.—CR, R
 *SIGNALER, M. M. Fleron & Son, Inc.
 STROMBERG-CARLSON TELEPHONE MFG. CO., 100 Carlson Rd., Rochester, N. Y.—CA, CR
 SUN RADIO CO., 212 Fulton St., New York, N. Y.—A, AR, AT, CO, CA, CR, D, R, T
 SUPREME INSTRUMENTS CORP., Greenwood, Miss.—FG
 TECHNICAL APPLIANCE CORP., 17 E. 16th St., New York, N. Y.—AR, C
 TECHNICAL PRODUCTS INTERNATIONAL, 135 Liberty St., New York, N. Y.—T
 TELERADIO ENGINEERING CORP., 484 Broome St., New York, N. Y.—CO
 TILTON ELECTRIC CORP., 15 E. 26th St., New York, N. Y.—AR
 UNITED STATES TELEVISION MFG. CORP., 220 E. 51st St., New York, N. Y.—R
 VERTI-FLEX ILLINOIS SEATING CO., 2138 N. Racine Ave., Chicago, Ill.—AR
 VERTROD MANUFACTURING CO., 132 Nassau St., New York, N. Y.—AR
 WARD PRODUCTS CORP., 1523 E. 45th St., Cleveland, Ohio—AR
 WILCOX ELECTRIC CO., 40th & State Line, Kansas City, Mo.—FA, P, R, T
 WINCHARGER CORPORATION, Sioux City, Iowa—AR, AT

HARDWARE—CONNECTORS & MISC. PARTS & SUPPLIES



Bakelite sheet, tubes & rods	B
Binding posts	BI
Cable connectors	CC
Coil dope	C
Coil shields	CO
Conduit fittings	CF
Couplings	CU
Engraving on bakelite panels	EB
Flexible control shafts	F
Fuses & mountings	FM
Grid clips	G
Grille cloth	GL
Grommets	GR
Jacks	JA
Mounting brackets	MO
Plugs	PL
Push-on knob springs	PS
Rivets	RI
Rubber bumper feet	RF
Screws	SC
Self-tapping screws	ST
Sockets	SK
Soldering lugs	SO
Special washers	SW
Springs	S
Spring clips, insulated; and/or un-insulated	SP
Spring washers	SR
Stampings	SM
Terminal strips	TS
Tube shields	TU
Washers, felt	W
Washers, fibre	WA
Washers, lock	WS
Miscellaneous screws, washers, etc.	M

AMERICAN PHENOLIC CORP., 1250 W. Van Buren St., Chicago, Ill.—CC, C, CF, GR, PL, SK, SO, TS, M
 AMERICAN RADIO HARDWARE CO., INC., 476 Broadway, New York, N. Y.—BI, CC, CO, GR, JA, MO, PL, SK, SM, SO, TS, TU, M
 ATLAS SOUND CORP., 1417 39th St., Brooklyn, N. Y.—CC, GL, PL
 AUDIO DEVELOPMENT CO., 123 Bryant Ave. N., Minneapolis, Minn.—JA
 BARKER & WILLIAMSON, Ardmore, Pa.—C, JA, PL
 *BIRNBACH, Birnbach Radio Co., Inc.
 BIRNBACH RADIO CO., INC., 145 Hudson St., New York, N. Y.—*Birnbach—CC, JA, PL, SK, SO, TS, M
 BOND PRODUCTS CO., 13139 Hamilton Ave., Detroit, Mich.—BI, CC, CO, GR, JA, MO, PL, SK, SO, TS, TU, M
 BUD RADIO, INC., 5205 Cedar Ave., Cleveland, Ohio—CC, CO, GR, JA, MO, PL, SK, SO, TS, TU, M
 CANNON ELECTRIC DEVELOPMENT CO., 3209 Humboldt St., Los Angeles, Calif.—CC, PL, SK
 CARRON MANUFACTURING CO., 415 S. Aberdeen St., Chicago, Ill.—C
 CINCH MANUFACTURING CORP., 2335 W. Van Buren St., Chicago, Ill.—BI, CC, GR, JA, MO, PL, SK, SO, TS, TU, M
 CINEMA ENGINEERING CO., 1508 W. Verdugo Ave., Burbank, Calif.—JA, MO, PL, SO, TS
 CONSOLIDATED WIRE & ASSOCIATED CORP., 512 E. Peoria St., Chicago, Ill.—C, JA
 CRESCENT TOOL & DIE CO., 4140 Belmont Ave., Chicago, Ill.—MO, M
 CRUMPACKER DISTRIB. CORP., 1801 Fannin St., Houston, Tex.—CC, CO, GL, GR, JA, MO, PL, SK, SO, TS, TU, M
 DOW RADIO SUPPLY CO., 1759 E. Colorado, Pasadena, Calif.—BI, CC, C, CO, GL, GR, JA, MO, PL, SK, SO, TS, TU, M
 EAGLE ELECTRIC MFG. CO., INC., 59 Hall St., Brooklyn, N. Y.—CC, PL, SK, TS
 EASTERN MIKE-STAND CO., 56 Christopher Ave., Brooklyn, N. Y.—PL
 HUGH H. EBY, INC., 4700 Stenton Ave., Phila., Pa.—BI, CC, JA, PL, SK, TS
 EMPIRE NOTION CO., 105 E. 29th St., New York, N. Y.—BI, GR, NO, SK, TU, M
 FAHNESTOCK ELECTRIC CO., 46-44 11th St., Long Island City, N. Y.—BI, CC, JA, SO, TS
 FEDERAL SCREW PRODUCTS CO., 24-26 S. Jefferson St., Chicago, Ill.—BI, CC, GR, JA, MO, PL, SK, SO, TS, M
 FEDERATED PURCHASER, INC., 80 Park Pl., New York, N. Y.—BI, CC, C, CO, GL, GR, JA, MO, PL, SK, SO, TS, TU, M
 FISCHER DISTRIB. CORP., 222 Fulton St., New York, N. Y.—BI, CC, C, CO, GL, GR, JA, MO, PL, SK, SO, TS, TU, M
 FONDA CORPORATION, 29 W. 57th St., New York, N. Y.—GL, GR, JA, TU
 GENERAL CEMENT MFG. CO., 919 Taylor Ave., Rockford, Ill.—C, GL, GR, JA, PL, SK, SO, M
 GOAT RADIO TUBE PARTS, INC., 314 Dean St., Brooklyn, N. Y.—TU
 GORDON SPECIALTIES CO., 1104 S. Wabash Ave., Chicago, Ill.—GR
 L. F. GRAMMES & SONS, INC., 361 Union St., Allentown, Pa.—CC, SK, SO, M
 EDWIN I. GUTHMAN & CO., INC., 400 S. Peoria St., Chicago, Ill.—CO
 HAMMARLUND MFG. CO., INC., 424 W. 33rd St., New York, N. Y.—CO, TU
 HARRISON RADIO CO., 12 W. Broadway, New York, N. Y.—BI, CC, C, CO, GR, JA, MO, PL, SK, SO, TS, TU, M
 A. G. HINTZE, 300 W. Adams St., Chicago, Ill.—GL
 HERBERT H. HORN, 1201 S. Olive St., Los Angeles, Calif.—BI, CC, C, CO, GL, GR, JA, MO, PL, SK, SO, TS, TU, M
 INSULINE CORP. OF AMERICA, 30-30 Northern Blvd., Long Island City, N. Y.—BI, CC, C, CO, GR, JA, MO, PL, SK, SO, TS, TU, M
 J. F. D. MANUFACTURING CO., 4111 Ft. Hamilton Pkwy., Brooklyn, N. Y.—CC, C, TU, M
 E. F. JOHNSON CO., Waseca, Minn.—JA, PL, SK, SO
 HOWARD B. JONES, 2300 Wabansia Ave., Chicago, Ill.—MO, PL, SK, SO, TS
 KELLOGG SWITCHBOARD & SUPPLY CORP., 6650 S. Cicero Ave., Chicago, Ill.—BI, CC, JA, PL, SK, SO, TS
 LAFAYETTE RADIO CORP., 100 6th Ave., New York, N. Y.—BI, CC, C, CO, GL, GR, JA, MO, PL, SK, SO, TS, TU, M
 *LAVA, American Lava Corp.
 LEOTONE RADIO CO., 63 Dey St., New York, N. Y.—MO
 LITTELFUSE, INC., 4757 Ravenswood Ave., Chicago, Ill.—FM
 M & H SPORTING GOODS CO., 512 Market St., Phila., Pa.—BI, CC, C, CO, GL, GR, JA, MO, PL, SK, SO, TS, TU, M
 MAJESTIC RADIO & TELEVISION CORP., 2600 W. 50th St., Chicago, Ill.—MO
 P. R. MALLORY & CO., INC., 3029 E. Washington St., Indianapolis, Ind.—CC, GR, JA, MO, PL, SK, SO, TS, M

MANUFACTURERS SCREW PRODUCTS, 214 W. Hubbard St., Chicago, Ill.—BI, GR, SO, ML
 MEISSNER MANUFACTURING CO., Mt. Carmel, Ill.—C, CO, SK, TS
 JAMES MILLEN MFG. CO., INC., 150 Exchange St., Malden, Mass.—BI, CC, C, CO, SK, TS, TU
 J. W. MILLER CO., 5917 S. Main St., Los Angeles, Calif.—*Miller Quality Products, *Miller—BI, CO, MO, SK, TS, TU
 *MILLER, J. W. Miller Co.
 *MILLER QUALITY PRODUCTS, J. W. Miller Co.
 MONTGOMERY WARD & CO., INC., 619 W. Chicago Ave., Chicago, Ill.—*Airline—CC, C, CO, GR, JA, MO, PL, SK, SO, TS, TU, M
 MUELLER ELECTRIC CO., 1583 E. 31st St., Cleveland, Ohio—SP
 THE MUTER COMPANY, 1255 S. Michigan Ave., Chicago, Ill.—SO
 NASH RADIO PRODUCTS CO., 6267 Gravois Ave., St. Louis, Mo.—C, GL
 NATIONAL COMPANY, INC., 61 Sherman St., Malden, Mass.—*National, *AC—BI, C, CO, CC, JA, PL, SK, TS, TU
 *NATIONAL, National Company, Inc.
 NEW ART SPECIALTIES, INC., 816 W. Erie St., Chicago, Ill.—MO, SO, M
 OFFENBACH ELECTRIC CO., 1452 Market St., San Francisco, Calif.—BI, CC, C, CO, GL, GR, JA, MO, PL, SK, SO, TS, TU, M
 PARISIAN NOVELTY CO., 3510 S. Western Ave., Chicago, Ill.—SM
 *PARKER-KALON, Parker-Kalon Corporation
 PARKER-KALON CORPORATION, 200 Varick St., New York, N. Y.—*Parker-Kalon—M, ST
 PAUL & BECKMAN, Div. of Phila. Lawn Mower & Mfg. Co., 4250 Wissahickon Ave., Phila., Pa.—CO, TS
 PHILCO RADIO & TELEVISION CORP., Tioga & "C" Sts., Phila., Pa.—BI, CC, CO, GL, GR, JA, PL, SK, SO, TS, TU, M
 PHILMORE MFG. CO., INC., 113 University Pl., New York, N. Y.—BI, JA, PL, SK
 RADIO ELECTRIC SERVICE CO., INC., N.W. Cor. 7th & Arch Sts., Phila., Pa.—BI, CC, C, CO, GL, GR, JA, MO, PL, SK, SO, TS, TU, M
 RADIO EQUIPMENT CORP., 326 Elm St., Buffalo, N. Y.—BI, CC, C, CO, GL, GR, JA, MO, PL, SK, SO, TS, TU, M
 RADOLEK COMPANY, 601 W. Randolph St., Chicago, Ill.—BI, CC, C, CO, GL, GR, JA, MO, PL, SK, SO, TS, TU, M
 ROGERS-MAJESTIC CORP., LTD., 622 Fleet St., Toronto, Can.—BI, CO, MO, TS, M
 WALTER L. SCHOTT CO., 5266-70 W. Pico Blvd., Los Angeles, Calif.—*Walisco—C
 MAURICE SCHWARTZ & SON, 710 Broadway, Schenectady, N. Y.—BI, CC, C, CO, GL, GR, JA, MO, PL, SK, SO, TS, TU, M
 SEATTLE RADIO SUPPLY CO., INC., 2117 2nd Ave., Seattle, Wash.—BI, CC, C, CO, GL, GR, JA, MO, PL, SK, SO, TS, TU, M
 SELECTAR MFG. CORP., 30 W. 15th St., New York, N. Y.—CC, JA, PL
 SHAKEPROOF LOCK WASHER CO., 2501 N. Keeler Ave., Chicago, Ill.—M
 SHELLEY RADIO CO., 1841 S. Flower St., Los Angeles, Calif.—BI, GR, JA, PL, SK, SO, TS, TU
 H. B. SHERMAN MFG. CO., 22 Barney St., Battle Creek, Mich.—CC, SO
 SORENG-MANEGOLD CO., 1901 Clibourn Ave., Chicago, Ill.—PL, SK, TS
 STANDARD ELEC. PRODUCTS CO., 417 1st Ave., N., Minneapolis, Minn.—TS
 STANLEY TOOLS, New Britain, Conn.—GR
 STEWART STAMPING CORP., 621 E. 216th St., New York, N. Y.—MO, SO
 SUN RADIO CO., 212 Fulton St., New York, N. Y.—BI, CC, C, CO, GL, GR, JA, MO, PL, SK, SO, TS, TU, M
 TELERADIO ENGINEERING CORP., 484 Broome St., New York, N. Y.—CC, C, CO, MO, SK, SO, TS
 TILTON ELECTRIC CORP., 15 E. 26th St., New York, N. Y.—TS
 THE TRIPLETT ELEC. INSTRUMENT CO., Bluffton, Ohio, *Triplett—JA, SK
 *TRIPLETT, The Triplett Elec. Instrument Co.
 *WALSCO—Walter L. Schott Co.
 X-L RADIO LABS., 420 W. Chicago Ave., Chicago, Ill.—BI
 ZIERICK MANUFACTURING CORP., 385 Gerard Ave., Bronx, N. Y.—SO
 THE BRUSH DEVELOPMENT CO., 3311-3405 Perkins Ave., Cleveland, Ohio—CH, HE, PP

HEADPHONES



Crystal	CH
Dynamic	DH
Hearing-aid (bone conduction)	HB

*AC, National Company, Inc.
 *AIRLINE, Montgomery Ward & Co., Inc.
 ALDEN PRODUCTS CO., 715 Center St., Brockton, Mass.—CC, C, GR, JA, PL, SK, SO, TS, M
 ALLIED RADIO CORP., 833 W. Jackson Blvd., Chicago, Ill.—BI, CC, C, CO, GL, GR, JA, MO, PL, SK, SO, TS, TU, M
 *ALSIMAG, American Lava Corp.
 AMERICAN LAVA CORP., Cherokee Blvd. & Manufacturers Rd., Chattanooga, Tenn., *Alsimag, *Lava—GR

Please say you saw it in the Radio-Craft "Classified Radio Directory"

Hearing-aid (earphone) . . . HE
 Magnetic MH
 Pillow phones PP

*AIRLINE, Montgomery Ward & Co., Inc.
ALLIED RADIO CORP., 833 W. Jackson Blvd., Chicago, Ill., *"Knight"—CH, HE, MH
CANADIAN MARCONI CO., 211 St. Sacramento St., Montreal, Can.—CH, DH, MH
C. F. CANNON CO., Springwater, N. Y.—MH
 *CARDAK—Electro-Voice Mfg. Co., Inc.
CARRON MANUFACTURING CO., 415 S. Aberdeen St., Chicago, Ill.—DH, MH
CHICAGO TELEPHONE SUPPLY CO., 1142 W. Beardsley Ave., Elkhart, Ind.—MH
 *COMMERCIAL—Trimm Manufacturing Co., Ltd., CRUMPACKER DISTRIB. CORP., 1801 Fannin St., Houston, Tex.—CH, MH
 *DEPENDABLE—Trimm Manufacturing Co., Ltd.
DOW RADIO SUPPLY CO., 1759 E. Colorado, Pasadena, Calif.—CH, DH, HB, HE, MH
ELECTRO-VOICE MFG. CO., INC., 1239 S. Bend Ave., S. Bend, Ind., *"Electro-Voice", *"Cardak"—DH
 *ELECTRO-VOICE—Electro-Voice Mfg. Co., Inc.
FEDERATED PURCHASER, INC., 80 Park Pl., New York, N. Y.—CH, DH, HB, HE, MH
FISCHER DISTRIB. CORP., 222 Fulton St., New York, N. Y.—CH, DH, HB, HE, MH
GLOBE PHONE MFG. CORP., Reading, Mass.—HB, HE, MH
HARRISON RADIO CO., 12 W. Broadway, New York, N. Y.—CH, HB, HE, MH
HERBERT H. HORN, 1201 S. Olive St., Los Angeles, Calif.—MH
INSULINE CORP. OF AMERICA, 30-30 Northern Blvd., Long Island City, N. Y.—MH
KELLOGG SWITCHBOARD & SUPPLY CO., 6650 S. Cicero Ave., Chicago, Ill.—MH
 *KNIGHT—Allied Radio Corp.
LAFAYETTE RADIO CORP., 100 6th Ave., New York, N. Y.—CH, HE, MH
LAUREHK RADIO MFG. CO., 3918 Monroe Ave., Wayne, Mich.—HB
T. R. McELROY, 100 Brookline Ave., Boston, Mass.—MH
M. & G. HEARING AIDS CO., 30 N. Michigan Ave., Chicago, Ill.—HB, HE, MH
M & H SPORTING GOODS CO., 512 Market St., Phila., Pa.—CH, MH
MAICO COMPANY, INC., 83 S. 9th St., Minneapolis, Minn.—DH, HB, HE, MH
MAJESTIC RADIO & TELEVISION CORP., 2600 W. 50th St., Chicago, Ill.—HB, HE
MEISSNER MANUFACTURING CO., Mt. Carmel, Ill.—MH
 *MONOBAR, Tibbetts Laboratories
MONTGOMERY WARD & CO., INC., 619 W. Chicago Ave., Chicago, Ill., *"Airline"—CH, HE, MH
E. A. MYERS & SONS, 306 Beverly Rd., Mt. Lebanon, Pittsburgh, Pa.—CH, HB, HE, MH
NORTHERN ELECTRIC CO., LTD., 1261 Shearer St., Montreal, Que., Can.—HB, HE, MH
OFFENBACH ELECTRIC CO., 1452 Market St., San Francisco, Calif.—CH, HB, HE, MH
PARAPHONE HEARING AID, INC., 4300 Euclid Ave., Cleveland, Ohio—HE, MH
PHILCO RADIO & TELEVISION CORP., Tioga & "C" Sts., Phila., Pa.—HE, MH
PHILMORE MANUFACTURING CO., INC., 113 University Pl., New York, N. Y.—MH
 *PROFESSIONAL, Trimm Manufacturing Co., Ltd.
RADIO ELECTRIC SERVICE CO., INC., N.W. Cor. 7th & Arch Sts., Phila., Pa.—CH, DH, HB, HE, MH
RADIO EQUIPMENT CORP., 326 Elm St., Buffalo, N. Y.—CH, MH
RADOLEK COMPANY, 601 W. Randolph St., Chicago, Ill.—CH, MH
RCA MANUFACTURING CO., INC., Camden, N. J.—HB, HE, PP
ROTOPHONE CORPORATION, 26 Journal Sq., Jersey City, N. J.—HB, HE
MAURICE SCHWARTZ & SON, 710-712 Broadway, Schenectady, N. Y.—CH, DH, HB, HE, MH
SEATTLE RADIO SUPPLY CO., INC., 2117 2nd Ave., Seattle, Wash.—CH, HB, HE, MH
SHELLEY RADIO CO., 1841 S. Flower St., Los Angeles, Calif.—CH, DH, MH
SUN RADIO COMPANY, 212 Fulton St., New York, N. Y.—CH, DH, MH
TAYLOR AIRPHONE PRODUCTS, INC., Long Beach Municipal Airport, Long Beach, Calif.—MH
TELEX PRODUCTS CO., 1645 Hennepin Ave., Minneapolis, Minn.—CH, HE
TIBBETTS LABORATORIES, Camden, Maine, *"Monobar"—CH, HE
TRIMM MANUFACTURING CO., LTD., 1770 W. Berteau, Chicago, Ill., *"Trimm", *"Commercial", *"Professional", *"Dependable"—HE, MH
 *TRIMM, Trimm Manufacturing Co., Ltd.
TRY-MO RADIO CO., INC., 85 Cortlandt St., New York, N. Y.—CH, DH, HB, HE, MH
UNIVERSAL MICROPHONE CO., LTD., 424 Warren Lane, Inglewood, Calif.—MH
VICTOR ANIMATOGRAPH CORP., Davenport, Iowa—DH, HE

HEARING-AIDS (Complete)



Desk type (battery and/or electric) C
 Portable, personal CP

Preceding Listings in RADIO-CRAFT'S CLASSIFIED RADIO DIRECTORY

Sec. I (Revised), April 1941:

Sec. II, Nov. '40:
 Amplifiers
 Antennas & Accessories
 Automatic Tuners & Parts
 Auto-Radio Controls
 Aircraft Radio (see Receiving Sets—including Adapters and Converters)
 Battery Chargers (& Parts)
 Batteries (& Cells) Dry & Wet (Storage)
 Books (see Service Manuals, Books & Magazines)
 Cabinets, Cases, Parts & Services
 Chemicals for Radio
 Coils & Transformers (R.F. & I.F.) & Accessories
 Coin Controls (see Records & Record-Playing Equipment; also, Receiving Sets)
 Condensers, Fixed
 Condensers, Variable
 Crystals (Quartz)
 Dials & Parts
 Electric Fence Controllers
 Electric-Generating Machines
 Electronics
 Electronic Musical Instruments & Parts
 Frequency Modulation Equipment
 Hardware—Connectors & Misc. Parts
 Headphones
 Hearing-Aids
 Hearing-Aid Parts
 Insulation
 Intercommunicating Systems
 Line Filters

Next month: Section III, revised.

Sec. III, Dec. '40:

Magnets
 Metal & Special Fittings (for Radio)
 Metal, Ore & Oil Locators
 Microphones
 Noise Elimination Equipment
 Paint, Cement & Wax Products
 Plastics
 Plastic Molders
 Radio Logs, Maps & Globes
 Receiving Sets (including Adapters & Converters)
 Records & Record-Playing Equipment

Sec. IV, Jan. '41:

Recording Equipment
 Resistors & Volume Controls (Attenuators & Networks)
 Schools
 Service Manuals, Books & Magazines
 Servicing Equipment
 Sound Systems, Amplifiers & Accessories

Sec. V, Feb. '41:

Speakers (& Parts)
 Switches & Relays
 Television
 Test Equipment—Laboratory & Production
 Tools
 Transformers & Chokes
 Transmitters (& Equipment)

Sec. VI, March '41:

Tubes (& Parts)
 Vibrators
 Wire
 Literature

The above back-issues of *Radio-Craft* are available at the regular price of 25c per copy.

Next month: Section III of the Classified Radio Directory, revised, with new classifications, and new names and addresses added; and with obsolete listings removed. Reserve your copy, today, from your regular newsdealer.

ACME HEARING AID CO., 516 5th Ave., New York, N. Y.—CP
 *AIRLINE, Montgomery Ward & Co., Inc.
 ALLIED ENGINEERING INSTITUTE, 85 Warren St., New York, N. Y.—C, CP
 ALLIED RADIO CORP., 833 W. Jackson Blvd., Chicago, Ill., *"Knight"—CP

AMPLIFIER CO. OF AMERICA, 17 W. 20th St., New York, N. Y.—C
 AUDIOGRAPH SOUND SYSTEMS, 1313 W. Randolph St., Chicago, Ill.—C
 CHICAGO SOUND SYSTEMS CO., 315 E. Grand Ave., Chicago, Ill.—C, CP
 *COMMERCIAL, Trimm Manufacturing Co., Ltd.
 *CO-RECHT, Electronic Sound & Music Co.
 CRYSTAL EAR, INC., 2007 S. Michigan Ave., Chicago, Ill.—C, CP
 *DEPENDABLE, Trimm Manufacturing Co., Ltd.
 *DICTAFILM, Miles Reproducer Co., Inc.
 ELECTRONIC SOUND & MUSIC CO., 10 Stuyvesant St., New York, N. Y., *"Co-Rect"—CP
 ERWOOD SOUND EQUIPMENT CO., 224 W. Huron St., Chicago, Ill.—C, CP
 EXECUTONE, INC., 415 Lexington Ave., New York, N. Y.—C
 *FILMGRAPH, Miles Reproducer Co., Inc.
 GEM EAR PHONE CO., INC., 47 W. 34th St., New York, N. Y.—C, CP
 GLOBE PHONE MFG. CORP., Reading, Mass.—C, CP
 CHARLES JACK MFG. CORP., 27 E. Philadelphia St., York, Pa.—C
 *KNIGHT, Allied Radio Corp.
 LAUREHK RADIO MFG. CO., 3918 Monroe Ave., Wayne, Mich.—C, CP
 M. & G. HEARING AIDS CO., 30 N. Michigan Ave., Chicago, Ill.—C, CP
 MAICO COMPANY, INC., 83 S. 9th St., Minneapolis, Minn.—C, CP
 MAJESTIC RADIO & TELEVISION CORP., 2600 W. 50th St., Chicago, Ill.—C, CP
 JOHN MECK INDUSTRIES, 1313 Randolph St., Chicago, Ill.—C
 MILES REPRODUCER CO., INC., 812 Broadway, New York, N. Y., *"Filmgraph", *"Dictafilm"—C, CP
 *MONOBAR, Tibbetts Laboratories
 MONTGOMERY WARD & CO., INC., 619 W. Chicago Ave., Chicago, Ill., *"Airline"—C, CP
 E. A. MYERS & SONS, 306 Beverly Rd., Mt. Lebanon, Pittsburgh, Pa.—C, CP
 NORTHERN ELECTRIC CO., LTD., 1261 Shearer St., Montreal, Que., Can.—C, CP
 PARAPHONE HEARING AID, INC., 4300 Euclid Ave., Cleveland, Ohio—C, CP
 *PROFESSIONAL, Trimm Manufacturing Co., Ltd.
 RAY-LAB COMPANY, Grand Central & 11th St., Elmira Heights, N. Y.—C
 *RAY-LAB, Ray-Lab Company
 ROTOPHONE CORPORATION, 26 Journal Sq., Jersey City, N. J.—C, CP
 TAY BERN EQUIPMENT CO., INC., 135 Liberty St., New York, N. Y.—CP
 TELEX PRODUCTS CO., 1645 Hennepin Ave., Minneapolis, Minn.—C, CP
 TIBBETTS LABORATORIES, Camden, Maine, *"Monobar"—CP
 TRIMM MANUFACTURING CO., LTD., 1770 W. Berteau, Chicago, Ill., *"Trimm", *"Commercial", *"Professional", *"Dependable"—C, CP
 *TRIMM, Trimm Manufacturing Co., Ltd.
 VACOLITE COMPANY, 3003 N. Henderson St., Dallas, Tex.—C, CP
 WEBSTER ELECTRIC CO., Clark & DeKanen Ave., Racine, Wis.—C, CP
 WESTERN ELECTRIC CO., INC., 300 Central Ave., Kearny, N. J.—CP

HEARING-AID PARTS



Batteries, miniature BM
 Cases C
 Condensers, small-space variable S
 Earphone (and/or Bone Conductors) E
 Microphones M
 Plugs & Sockets P
 Resistors, special small-space variable R
 Testers TE
 Transformers & chokes TC
 Tubes (and/or sockets) T

AEROVOX CORPORATION, New Bedford, Mass.—S
 ALLIED RADIO CORP., 833 W. Jackson Blvd., Chicago, Ill., *"Knight"—T
 AMERICAN MICROPHONE CO., INC., 1915 S. Western Ave., Los Angeles, Calif.—M
 AMPLIFIER CO. OF AMERICA, 17 W. 20th St., New York, N. Y.—C, M, R, TC
 ASTATIC MICROPHONE LAB., INC., 830 Market St., Youngstown, Ohio—M
 AUDIO DEVELOPMENT CO., 123 Bryant Ave. N., Minneapolis, Minn.—TC

Please say you saw it in the Radio-Craft "Classified Radio Directory"

CLASSIFIED RADIO DIRECTORY

10 BEST RADIO BOOKS 10¢ ea.

RADIO FANS EVERYWHERE—these fine ten cent text books give you an excellent foundation for the study of RADIO. They are clearly written, profusely illustrated and contain over 15,000 words in each book. You'll be

amazed at the wealth of information contained in these handy books. Excellent for reference—ideal for every technical library. **YOUR MONEY BACK** if you are not satisfied. **PROMPT SHIPMENTS**

No. 1
HOW TO BUILD FOUR DOERLE SHORT WAVE SETS

Thousands of radio fans have built the famous DOERLE Short Wave Receiver. So insistent has been the demand for these receivers, as well as construction details that this book has been specially published. Contains **EVERYTHING** that has ever been printed on these famous receivers.

No. 2
HOW TO MAKE THE MOST POPULAR ALL-WAVE AND 2-TUBE RECEIVERS

This book contains a number of excellent sets, some of which have appeared in past issues of RADIO-CRAFT. These sets have been carefully engineered. They are not experiments. Not only are these sets described in this book, but it contains all of the illustrations, hookups, etc.

No. 3
ALTERNATING CURRENT FOR BEGINNERS

This book gives the beginner a foothold in electricity and Radio. Electric circuits are explained. Ohm's Law, one of the fundamental laws of radio, is explained; the generation of alternating current; sine waves; the unit—volts, amperes, and watts are explained. Condensers, transformers, A.C. instruments, motors and Generators.

No. 4
ALL ABOUT AERIALS

This book explains the theory underlying the various types of aerials: the inverted "T", the Doublet, the Doublet, etc. It explains noise-free reception, how low-impedance transmission lines work; why transposed lead-ins are used. It gives in detail the construction of aerials suitable for long-wave broadcast receivers, for short-wave receivers and for all-wave receivers.

No. 5
BEGINNERS' RADIO DICTIONARY

Are you puzzled by radio language? Can you define Frequency? Kilocycle? Tetrad? Screen grid? Baffle? Anode? Triode? Pole? Impedance? Joule's Law? Harmonic? Gravity Cell? If you cannot define these very important radio words and dozens of other, more technical, terms used in all radio magazines and instruction books, you need this book in your library.

No. 6
HOW TO HAVE FUN WITH RADIO

Stunts for parties, practical jokes, scientific experiments and other amusements which can be done with your radio set are explained in this fascinating volume. It tells how to make a newspaper talk—how to produce silent music for dances—how to make a "silent radio" unit, usable by the deaf—how to make toys which dance to radio music, etc., etc.

No. 7
HOW TO READ RADIO DIAGRAMS

All of the symbols commonly used in radio diagrams are presented in this book, together with pictures of the apparatus they represent and explanations giving an easy method to memorize them. This book by Robert Eichberg, the well-known radio writer and member of the editorial staff of RADIO-CRAFT Magazine, also contains two dozen picture-wiring diagrams of simple radio sets that you can build.

No. 8
RADIO FOR BEGINNERS

Hugo Gernsback, the international, ally famous radio pioneer, author and editor, whose famous magazines, RADIO AND TELEVISION and RADIO-CRAFT are read by millions, scores another triumph with this new book. Any beginner who reads it will get a thorough ground work in radio theory, clearly explained in simple language, and through the use of many illustrations. Analogies are used to make the mysteries of radio clear.

No. 9
SIMPLE ELECTRICAL EXPERIMENTS

Over 100 interesting and practical electrical experiments are described in this book, covering every branch of electricity—from simple experiments with magnets to high frequency "stunts". All of the experiments described can be carried out with simple apparatus, most of which can be found about the home.

No. 10
TELEVISION

Every one is asking the question: How does television work? This book explains all of the different systems of television from the simplest to the most complex. It describes in A-B-C style just how the image is scanned, how the scene is picked up by the television camera and broadcast to your home, etc. Various types of television systems are described.

BOOKS ARE ALL UNIFORM

Every book in the GERNSBACK EDUCATIONAL LIBRARY has 32 pages—with illustrations varying from 60 to 66 in number. Each title volume contains over 15,000 words. Positively radio's greatest book buy! If you do not think these books worth the price asked, return them in 24 hours and your money will be instantly refunded.

RADIO PUBLICATIONS • 20 VESEY STREET • NEW YORK, N. Y.

RADIO PUBLICATIONS, Dept. RC-5-41
20 VESEY STREET, NEW YORK, N. Y.
Gentlemen: Please send immediately, POSTPAID, the book numbers circled below. I am enclosing cents—each book being 10c.

1 2 3 4 5 6 7 8 9 10
NEW NEW

Send FREE listing of 48 new 10c publications.

Name Address

City State

Remit by check or money order—register letter if you send cash or unused U. S. postage stamps.

MAIL COUPON TODAY!

- BOND PRODUCTS CO., 13139 Hamilton Ave., Detroit, Mich.—C
THE BRUSH DEVELOPMENT CO., 3311-3405 Perkins Ave., Cleveland, Ohio—E, M
BURGESS BATTERY CO., Freeport, Ill.—BM
CANADIAN MARCONI CO., 211 St. Sacramento St., Montreal, Que., Can.—R, TC, T
*CARDAK—Electro-Voice Mfg. Co., Inc.
CHICAGO TELEPHONE SUPPLY CO., 1142 W. Beardsley Ave., Elkhart, Ind.—R
CLAROSTAT MFG. CO., INC., 285 N. 6th St., Brooklyn, N. Y.—R
*COMMERCIAL—Trimm Manufacturing Co., Ltd.
*CO-RECHT—Electronic Sound & Music Co.
*DEPENDABLE—Trimm Manufacturing Co., Ltd.
*DICTAFILM—Miles Reproducer Co., Inc.
DOW RADIO SUPPLY CO., 1759 E. Colorado St., Pasadena, Calif.—E, M, R, TC, T
ELECTRONIC APPLICATIONS, Brunswick, Maine—TC
ELECTRONIC SOUND & MUSIC CO., 10 Stuyvesant St., New York, N. Y., *Co-Rect"—C
ELECTRO-VOICE MFG. CO., INC., 1239 S. Bend Ave., S. Bend, Ind., *Electro-Voice", "Cardak"—M
*ELECTRO-VOICE—Electro-Voice Mfg. Co., Inc.
*FILMGRAPH—Miles Reproducer Co., Inc.
GEM EAR PHONE CO., INC., 47 W. 34th St., New York, N. Y.—E, M
GLOBE PHONE MFG. CORP., Reading, Mass.—C, E, M, TC, T
EDWIN I. GUTHMAN & CO., INC., 400 S. Peoria St., Chicago, Ill.—TC
HARRISON RADIO CO., 12 W. Broadway, New York, N. Y.—R, T
HOLLYWOOD TRANSFORMER CO., 5334 Hollywood Blvd., Hollywood, Calif.—TC
HYGRADE SYLVANIA CORP., 500 5th Ave., New York, N. Y.—T
HYTRONIC LABORATORIES, 23 New Derby St., Salem, Mass.—T
INTERNATIONAL RESISTANCE CO., 401 N. Broad St., Phila., Pa.—R
INTERNATIONAL TRANSFORMER CO., 17 W. 20th St., New York, N. Y.—TC
*KNIGHT—Allied Radio Corp.
LAFAYETTE RADIO CORP., 100 6th Ave., New York, N. Y.—E, M, R, TC, T
LAUREHK RADIO MFG. CO.—3918 Monroe Ave., Wayne, Mich.—C, E
LEKTRA LABORATORIES, INC., 30 E. 10th St., New York, N. Y.—M
M. & G. HEARING AIDS CO., 30 N. Michigan Ave., Chicago, Ill.—C, E, M, R, TC, T
MAICO CO., INC., 83 S. 9th St., Minneapolis, Minn.—C, E, M, P, R
P. R. MALLORY & CO., INC., 3029 E. Washington St., Indianapolis, Ind.—R
MILES REPRODUCER CO., INC., 812 Broadway, New York, N. Y., *Filmgraph", "Dictafilm"—M
*MONOBAR—Tibbetts Laboratories
NORWALK TRANSFORMER CORP., 50 Day St., S. Norwalk, Conn.—TC
OFFENBACH ELECTRIC CO., 1452 Market St., San Francisco, Calif.—E, M, R, TC, T
*PROFESSIONAL—Trimm Manufacturing Co., Ltd.
RAYTHEON PRODUCTION CORP., Small-Tube Division, 55 Chapel St., Newton, Mass.—T
*ROCKET—Shure Brothers
ROTOPHON CORPORATION, 26 Journal Sq., Jersey City, N. J.—C, E, M
SEATTLE RADIO SUPPLY CO., INC., 2117 2nd Ave., Seattle, Wash.—E, R, TC, T
SELECTAR MFG. CORP., 30 W. 15th St., New York, N. Y.—M
SHURE BROTHERS, 225 W. Huron St., Chicago, Ill., *Shure", "Unidyne", "Uniplex", "Rocket", "Stratoliner", "Super-Level", "Ultrawide-Range", "Zephyr"—M
*SHURE—Shure Brothers
STACKPOLE CARBON CO., Tannery St., St. Marys, Pa.—R
THE STERLING MFG. CO., 9205 Detroit Ave., Cleveland, Ohio—TE
*STRATOLINER—Shure Brothers
*SUPER-LEVEL—Shure Brothers
TAY BERN EQUIP. CO., INC., 135 Liberty St., New York, N. Y.—BM, E, M, TC, T
TELERADIO ENG. CORP., 484 Broome St., New York, N. Y.—TC
TELEX PRODUCTS CO., 1645 Hennepin Ave., Minneapolis, Minn.—C, E, M, R, TC
THORDARSON ELECTRIC MFG. CO., 500 W. Huron St., Chicago, Ill.—TC
TIBBETTS LABORATORIES, Camden, Maine, *Monobor"—E, M
TRIMM MANUFACTURING CO., LTD., 1770 W. Berneau, Chicago, Ill., *Trimm", "Commercial", "Professional", "Dependable"—TC
*TRIMM—Trimm Manufacturing Co., Ltd.
THE TURNER CO., 909 17th St., Cedar Rapids, Iowa, *Turner"—M
*TURNER—The Turner Co.
*ULTRAWIDE-RANGE—Shure Brothers
*UNIDYNE—Shure Brothers
*UNIPLEX—Shure Brothers
UNITED TRANSFORMER CORP., 150 Varick St., New York, N. Y.—TC
*ZEPHYR—Shure Brothers

SIMPLE PHONOGRAPH OSCILLATOR

● WITH the recent interest in *phonograph oscillators*, many experimenters have wanted to find a really simple and inexpensive unit. The one illustrated here fills the bill entirely.

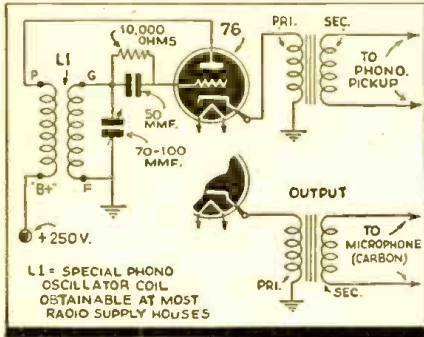

The diagram is nearly self-explanatory, except that the transformer is an audio inter-stage unit, used back to front. If for home broadcasting, you desire to use a microphone, use a "tube to voice coil" output transformer. A word of warning; tune this to the high-frequency end of the broadcast band, and use no antenna. The F.C.C. doesn't like people who do otherwise!

EUGENE SIMPSON,
Naperville, Ill.

IMPROVED MERCURY SWITCH

● A SWITCH may be improvised from the starter of a fluorescent light. I used a burned-out starter (frequently obtainable free from electric shops).

I removed the switch from its metal shell, broke off the small glass tip, and poured just enough mercury into the switch to close the contacts. Then by plugging the hole with a match and pouring some glue on it, I had a dandy mercury tilt-switch.

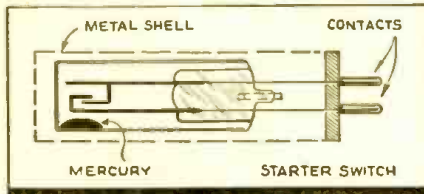

A switch of this type may be used on furnace controls, thermostatic controls, etc. Taped on a potentiometer shaft, it may be used on tilting surfaces; and, on rotating devices, to shut off and turn on the current at different intervals. It also may be used with a toggle switch by being taped to it.

HOMER L. DAVIDSON,
Fort Dodge, Iowa

"A" & "B" SUPPLY

● BATTERIES as the power source for signal generators often give reason for trouble by poor contacts, loss of power, etc. On the other side, when substituting a battery supply for a line power supply, be sure that it works "batterylike," with stability of voltage and as humless as possible.

Here is the description of a unit which corresponds to this condition, and which was built for use with a battery-operated signal generator, using 2 type 30 tubes with their filaments connected in series (Readrite "Ranger," model 557).

As the figure shows, the drain of the bleeder resistor, which is 0.06-amp. is used for the filament current of the type 30 tubes. The plate current for the tubes, taken from a tap of the same resistor, is so

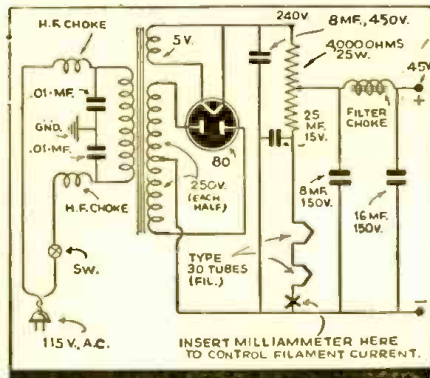

little that it does not influence the working conditions of the resistor. In the same manner, the filament resistance can be neglected in comparison with the bleeder resistor. The unit, built in a metal case, with all connections to it except the line strip blinded (author's copy—presumably meaning protected against accidental contact.—*Editor*), gives excellent results in voltage stability and there isn't any noticeable hum. Note that the case is only connected to the ground at the point marked on the primary side of the transformer and not to any point on the secondary side.

It is easy to modify the unit for any other tube or tubes, calculating the bleeder resistor by Ohm's law. For instance, if the output voltage of the rectifier tube is supplied with 300 volts, and the filament current needed is 0.120-amp. (1C6 tube), the value of the bleeder resistor has to be 2,500 ohms, rated at 50 watts, as it has to support about 35 watts. In this case it is recommended to use a 5Z3 rectifier.

FRANZ PLACZEK,
Porto, Portugal

FREE! RADOLEK'S
NEW 1941 RADIO
PROFIT GUIDE
Bargains!
Galore Like This •

PROFESSIONAL TYPE
10" RECORDING DISCS
only 19¢

Made by foremost manufacturer. Proven equal or superior to any discs of this type regardless of cost. These blanks have very slight imperfections but guaranteed to make perfect recordings of your money back. Coated on both sides—heavy metal base—non-inflammable. Big savings!

6" Discs—10c. 8"—14c. 10"—19c. 1c less in 25 lots. Send no money—shipped C.O.D. plus postage.



EVERYTHING NEW IN RADIO
AT BARGAIN PRICES!



Shows hundreds and hundreds of up-to-the-minute radio parts, sets, accessories, ham gear, electric appliances and supplies. Indispensable to every amateur, experimenter, set builder, sound engineer and service man. Keep up with radio and all its phases—send for the big FREE Radolek Profit Guide now! DON'T WAIT—SAVE MONEY AT RADOLEK.



SEND TODAY! PASTE ON A POST CARD

RADOLEK CO., Dept. C-54
601 W. Randolph St., Chicago, Ill.

Send FREE Catalog
 Ship _____ Discs Size _____ inches C.O.D. Plus Postage

Name _____ Dealer?.....
Address _____
Experimenter?..... Serviceman?..... Amateur?.....

Get This Electric Dry Shaver
ABSOLUTELY FREE!

JUST THINK OF IT—you can get absolutely FREE, the useful DRY ELECTRIC SHAVER which is shown at the left. This ELECTRIC DRY SHAVER is sent to you by the publishers with a one-year subscription to RADIO-CRAFT.

Here Are the Features of The ELECTRIC DRY SHAVER

Constructed of metal with attractive red bronze finish. Scientifically constructed to give a perfectly clean shave. 5-foot rubber insulated cord and plug. Constructed to last for many years.

Operates from 110-volt, 60-cycle A.C. electric line. Carries a two-year manufacturer's guarantee. A fine quality, self-sharpening toilet necessity.

Send your subscription to RADIO-CRAFT for One Year (12 issues) and receive absolutely FREE one of these remarkable Electric Dry Shavers. New subscribers are accepted or you may extend your present subscription another twelve months. Mail your remittance of \$2.00 (plus 25c for shipping charges on Shaver) to the publishers. (Canada and foreign \$2.75.) You will receive your DRY ELECTRIC SHAVER immediately by return mail. Use coupon below to enter your subscription.

RADIO-CRAFT
20 Vesey Street, New York, N. Y.

RADIO-CRAFT, 20 Vesey Street, New York, N. Y.

Gentlemen: Enclosed find my remittance of \$2.00 for which enter my subscription to RADIO-CRAFT for one year (12 issues). Send me immediately FREE ELECTRIC DRY SHAVER (Canada and foreign \$2.75). In U. S. add only 25c additional to cover shipping charges on Shaver.

New Subscriber Extend Present Subscription

Name _____
Address _____
City _____ State _____
(Send remittance by check, money order or unused U.S. Postage Stamps. Register letter if you send cash or stamps.) RC-541



OPERATES ON
110-VOLT, 60-CYCLE
A.C. LINE

WE SHIP ELECTRIC DRY SHAVER THE SAME DAY YOUR SUBSCRIPTION ORDER IS RECEIVED.

CLIP COUPON— AND MAIL!

Index to advertisers

ELECTRONIC EQUIPMENT

Electronic Products Company.....662, 684

PUBLISHERS

Amplifier Co. of America.....647
 Data Print Co.....670
 Miller, Wayne.....647
 National Plans Inst.....676
 Radercraft Publications, Inc.....672, 695, 698
 Radio & Technical Pub. Co.....676
 Radio Publications.....702
 Supreme Publications.....644, 677
 Technifax.....690, 695

RADIO PARTS

Amperite Co.....Inside Front Cover
 Dumont Electric Co., Inc.....676
 Hammarlund Mfg. Co.....662
 International Resistance Co.....655
 National Union Radio Corp.....659
 Solar Mfg. Corp.....677
 Sprague Products Co.....681

RADIO SETS

Harrison Radio Co.....648
 Midwest Radio Corp.....684
 Radio Electric Service Co.....667

RADIO SUPPLY HOUSES

Allied Radio Corp.....687
 Burstein-Applebee Co.....647
 Radolek Co.....703
 Sears, Roebuck & Company.....645

SCHOOLS

Capitol Radio Eng. Inst.....646
 Coyne Radio School.....646
 Lincoln Engineering School.....646
 National Radio Institute.....641
 National Schools.....646
 Port Arthur College.....644
 Radio Training Assoc.....658
 RCA Institutes.....646
 Sprayberry Academy of Radio.....646
 Inside Back Cover

SOUND & RECORDING EQUIPMENT

Amplifier Co. of America.....662, 677, 684
 Atlas Sound Corporation.....680
 Jensen Radio Mfg. Co.....663
 Lake Radio Sales Co.....658
 Lifetime Corp., The.....662
 John Meck Industries.....670
 Meissner Mfg. Company.....665
 Regal Amplifier Mfg. Corp.....657
 Universal Microphone Co., Ltd.....671
 University Laboratories.....670

TEST EQUIPMENT

Radio City Products Co.....658
 RCA Manufacturing Co., Inc.....Back Cover
 Readrite Meter Works.....663
 Supreme Instruments Corp.....671
 Triplett Electrical Instrument Co.....643
 Weston Elec. Instrument Corp.....677

TUBES

Hygrade Sylvania Corp.....675

MISCELLANEOUS

Atlas Press Co.....684
 Classified Section.....694
 Flight Magazine.....695
 W. W. Grainger, Inc.....681
 Lancaster, Allwine & Rommel.....684
 Moody, Willard.....694
 Onan, D. W., & Sons.....646
 Premium Distributing Service.....690
 Radio Servicemen of America, Inc.....686
 Walter L. Schott Co.....671
 Wellworth Trading Co.....680
 Woodstock Typewriter Co.....680

(While every precaution is taken to insure accuracy, we cannot guarantee against the possibility of an occasional change or omission in the preparation of this index.)

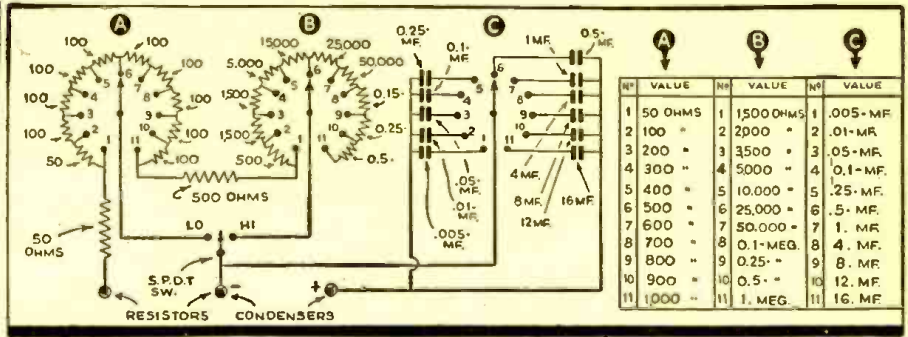

SUBSTITUTION BOX

See Diagram Above

● AN inexpensive substitution box can be made in the service shop, from standard parts. Servicemen that have never used an instrument of this kind have no idea what a time saver it is.

Here is a circuit of one that I have been using for some time, and which has proved very satisfactory. Small cards can be typed and placed above each pointer.

GEORGE HUFFMASTER,
 Detroit, Mich.

RESIN PREPARATION FOR LOOSE DIAL CORDS

● HERE'S a sure cure for those slipping dial cords. Obtain 3 ozs. of ether and 2 ozs. of powdered resin (or "rosin") from the drug store. Just enough resin is dissolved in the ether to form a thick liquid. This is applied to the dial cord with a small brush. The ether will evaporate leaving the resin on the cord. Your supply must be kept sealed or, due to the evaporation of the ether, it will return to a solid form.

EARL GARNER,
 Knightstown, Ind.

BOOK REVIEWS

YOUR CAREER IN RADIO. by Norman V. Carlisle and Conrad C. Rice (1941). Published by E. P. Dutton & Co., Inc. Cloth covers, size 8 1/4 x 5 1/2 ins., 189 pages. Price \$2.00.

Here is another of those books which tell about the possibilities for employment in the various fields of radio. Treatment is mainly about broadcasting, including television.

The book breaks away from the conventional method of presentation by being built in story form around the conducted tour of 3 representative boys, from a high school, through a large broadcast station. The boys are given an opportunity to fire questions at and receive direct answers from the various technicians, studio personnel, etc., employed in putting a sight or sound program on the air. It is sugar-coated knowledge, about radio broadcasting, for the embryo broadcast worker.

RUTHERFORD, by A. S. Eve. Published by Macmillan Company, Cambridge, England. Cloth covers, size 10 x 6 1/2 ins., 436 pages. Price \$5.00.

This authorized biography constitutes the life and letters of Lord Rutherford. The book is based on the collection of books, papers, etc., in the Cavendish Laboratory, University of Cambridge.

Recommended for the reading table of advanced technicians, this book delineates the work of a scientist who made many outstanding contributions to his chosen field of endeavor.

Among the discoveries credited to work by the author are the following: Magnetic Detector (work which Marconi completed); co-worker with Sir J. J. Thomson at Cambridge in determining laws governing the flow of electricity in a gas (ion theory); discovery and naming of uranium alpha and beta rays, the first-known radioactive gas (thorium emanation).

CHAMBERS TECHNICAL DICTIONARY, Edited by C. F. Tweney and L. E. C. Hughes. Published by The Macmillan Co., New York. Cloth covers, size 8 1/4 x 5 1/2 ins., 957 pages, occasional illustrations. Price \$5.00.

A staff of 30 experts under the editorship of Messrs. Tweney and Hughes has compiled in this extensive work all the major terms used in pure and applied science, medicine, the chief manufacturing industries, engineering, construction and the mechanical trades. In this rapidly-expanding technological world, this work stands as a beacon, in clearly presenting accepted definitions of existing terms, written by specialists.

The topics of interest to radio technicians which are covered in this book include the following: Acoustics, Dielectrics, Electrical Communication, Electrical Engineering, Measuring Instruments, Oscilloscopy, Photoelectric Cells, Physics, Radio and Television.

INTRODUCTION TO ELECTRICAL MACHINES, by A. W. Hirst (1940). Published by Blackie and Son, Ltd., London, England. Cloth covers, size 6 x 9 ins., profusely illustrated, 122 pages. Price, \$2.25.

To judge by the title, this book contains little of interest for the average radio man, and even the publishers of this book refer to it as an engineering textbook.

The fact of the matter is, however, that "Introduction to Electrical Machines" should be on the shelf of every serious radio man; if in addition the reader is familiar with algebra, then we add, "positively." A fair impression of the scope of the book may be obtained by review of its chapter titles: Electromagnetism and Electromagnetic Induction; The Magnetic Circuit and Magnetic Calculations; The Electromagnetic Machine; Insulation and Insulating Materials; Losses—Heating and Ventilation of Machines; Wave Form and Harmonic Analysis.

We would like to see the author do a companion book on Transformers.

INTERNATIONAL ELECTROTECHNICAL VOCABULARY. (Reproduced 1940). Published by Unwin Brothers, Ltd., London, England. Available in the U.S.A. from American Standards Association, New York, N. Y. Cloth covers, size 11 1/2 x 8 ins., 311 pages. Price \$2.50.

This photo-offset book contains no illustrations but it does include definitions of all the major terms the technician will be likely to encounter in reading articles in English and in French; the terms but not their definitions are further translated in Esperanto, German, Italian and Spanish.

Students who may have occasion to double-check on original technical literature in foreign languages will welcome this authoritative work.

An index in 6 languages greatly facilitate cross-references. The book is divided into groups as follows: Fundamental Definitions; Machines and Transformers; Switchboards and Apparatus for Connections and Regulations; Apparatus for Scientific and Industrial Measurements; Production, Transmission, and Distribution of Energy; Electric Traction; Electromechanical Applications; Electric Heating Applications; Lighting; Electrochemistry; Telegraphy and Telephony; Radio Communications; Radiology; Electrobiological.

NEXT MONTH . . .

. . . A radio Serviceman from Shanghai tells about servicing radio sets in China.
 . . . A coil manufacturer gives the "inside" story on coils in Frequency Modulation receivers.
 . . . A custom set builder tells how to make a "personal" radio transmitter.

FULL EQUIPMENT

Included WITH

SPRAYBERRY RADIO TRAINING!

Experience Easily Acquired at Home!



HOW TO MAKE MONEY IN RADIO
 SPRAYBERRY ACADEMY OF RADIO

OVER 100 EXPERIMENTS

plus Many Other Special Features

ALL DESIGNED TO HELP YOU MAKE FAST PROGRESS!

SPRAYBERRY Training starts right at the beginning of Radio . . . unfolds each subject in a simplified, logical, understandable style. You easily learn Television, Frequency Modulation, Signal Tracing, Mobile Radio (Auto-Tank), Aviation Radio, Electronics, Facsimile Radio, Radio Set Repair and Installation Work. You learn quickly in your spare hours . . . AT HOME OR AT CAMP.

Training Prepares You for a Business of Your Own . . . Or Good Radio Jobs at Excellent Pay!

The great, fascinating and progressive field of Radio and Television offers many opportunities to the man who wants to get ahead. There is good money to be made. My Training is designed to give you quick access to these opportunities. SPRAYBERRY Methods are thorough and practical. Your Training will not interfere with your present work.

You Get Professional Test Equipment plus Experimental Outfits!

. . . Includes 146 RADIO PARTS for building a complete Receiver, RADIO TOOLS and a modern TESTER-ANALYZER. You also receive 8 BIG SHIPMENTS OF RADIO EQUIPMENT for conducting actual experiments with your own hands. I show you how to create Radio defects . . . how to correct them. This practical "beforehand" experience will come in handy again and again when you are called on to do actual Radio repair work later on.

146 RADIO PARTS

RADIO TOOLS

TESTER-ANALYZER

All Equipment Becomes Your Personal Property

READ WHAT THESE FELLOWS SAY ABOUT THE NEW PRACTICAL SPRAYBERRY TRAINING

"GROSSED BETWEEN \$150 AND \$200"

"Since finishing your training I've started in the Radio repair business. I have about all the work I can take care of. I have grossed between \$150 and \$200 in the last few months in my spare time. I think your Course is 'tops'!"
 W. Francis Waseka, Fountain City, Wisconsin.

"SALARY HAS INCREASED"

"Your Radio training has made it possible for me to make more money. My salary has increased from \$40.00 to around \$50.00 per week. I now have about all the Radio repair work I can handle."
 Asa Smith, P. O. Box 528, Fort Owenworth, Ky.

"MADE AS MUCH AS \$8 A DAY"

"The instruments you have sent me helped me in solving Radio problems. I am building up my business by using all your methods, have made as much as \$8 in one day. L. R. Lanole, 316 Dudley Street, Providence, R. I.



No Previous Experience Needed

It makes no difference what your education has been. I can fit you quickly for a good-paying Radio job. I make it easy for you to grasp Radio principles and remember them. Your success is my full responsibility.

EARN WHILE YOU LEARN

My BUSINESS BUILDERS show you how to put your equipment to actual use in handling money-making Radio Service Jobs shortly after you begin training.

Learn More About the SPRAYBERRY Method And How Easy It is to Start

The complete details of my fundamental Course and Advanced Training Course . . . all features are fully described in my new, valuable 52-page FREE Book. Send for your copy. No obligation.

DON'T DELAY! ACT NOW!

SPRAYBERRY ACADEMY OF RADIO

F. L. Sprayberry, Pres.
 420-E University Place, N. W.
 Washington, D. C.

Please send my FREE copy of "HOW TO MAKE MONEY IN RADIO."

Name Age

Address

City State

Tear off this coupon, mail in envelope or paste on penny postcard.

Cash In on Radio's Rich Opportunities

No matter if you desire to BE YOUR OWN BOSS in your own business or hold down a good job in Radio, my Training will give you the useful information and knowledge to win success. Days of delay mean precious time wasted. Start training for a money-making Radio career—right now.

REMEMBER —THE SPRAYBERRY COURSE IS SOLD UNDER A MONEY-BACK AGREEMENT

RUSH THIS COUPON for BIG FREE BOOK
 GIVING COMPLETE FACTS

RE-SET PUSH BUTTONS THE *Rapid* WAY!

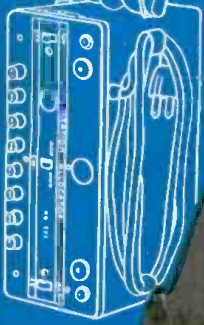

RCA Station Allocator

Covers all push-button setting and alignment work. \$ **17.50**
Operates from either self-contained batteries or a-c.
Stock No. 171—Price

The RCA Station Allocator is an indispensable instrument for the service dealer who really plans to "cash in" on his greatest business-building opportunity in years. With it, you can handle more push button receiver re-tuning jobs in less time, with less effort and at greater profits. Moreover, it will serve as a useful shop instrument long after the present re-allocation is forgotten.

The Allocator is speedy, accurate, portable. Eight push buttons can quickly be set up to desired frequencies. Operation is with or without modulation. It then serves as an oscillator for rapid identification of desired stations during the re-tuning of receivers. Two buttons can be tuned to i-f frequencies if desired, thus providing remarkable flexibility for all alignment as well as push-button setting work. The Allocator operates from either a-c or self-contained batteries.

Only one adjustment is required for each frequency. What's more, thanks to the Allocator's magnetite core inductances and polystyrene condensers, these adjustments *stay put*. Weight is only 5½ lbs. with batteries. Size is 5" high, 8¾" long and 3¾" deep.

See the Allocator at your RCA Test Equipment Distributor's today. Prepare now for faster work and bigger profits!

SPECIFICATIONS

PUSH-BUTTON RANGES:

Buttons 1 and 2	(approximately)	405-825 kc.
Buttons 3, 4, and 5	"	600-1185 kc.
Buttons 6, 7, and 8	"	820-1700 kc.

TUBE COMPLEMENT:

1 RCA-1R5 as r-f oscillator, 1 RCA-6H6 for a-c rectification, 1 neon tube for a-f oscillator and pilot lamp.

Another RCA Time-Saving Money-Maker

RCA Junior VOLT-OHM-YST

Costing only a little more than an ordinary volt-ohmmeter, the RCA Junior VoltOhmyst gives you electronic push-pull operation with all the time and money-saving features of the famous Rider VoltOhmyst circuits plus

the addition of an isolated rectifier-type a-c voltmeter! Special protective features guard against meter burn-out for d-c volts and ohms measurements. It is an instrument no wide-awake technician can afford to miss!

Price, Complete \$ **34.95** Stock No. 165



Test Equipment

YOUR KEY TO SUCCESSFUL
SERVICING THE OPERATOR

RCA MANUFACTURING CO., Inc., Camden, N. J. A Division of the Radio Corporation of America

In Canada: RCA VICTOR COMPANY, Ltd., Montreal



ADV Plans, LLC

Copyright Notice:

The entire contents of this CD/DVD are copyright 2014 by ADV Plans, LLC. All Rights Reserved.

Reproduction or distribution of this disk, either free or for a fee is strictly prohibited. We actively monitor and remove listings on eBay thru Vero.

You are free to copy or use individual images in your own projects, magazines, brochures or other school projects.

Only the sellers listed here are authorized distributors of this collection:
www.theclassicarchives.com/authorizedsuppliers

Please view our other products at
www.theclassicarchives.com,
or our ebay stores:

[TheClassicArchives](#)
[ADVPlans](#)
[SuperShedPlans](#)

